

# Smart Battery Monitoring And Protection System For Electric Vehicles Using IOT

Elamathi G<sup>1</sup>, Jothilakshmi V<sup>2</sup>, Sathiyavani K<sup>3</sup>, Manju K<sup>4</sup>

<sup>2, 3, 4</sup>Assistant Professor/ECE

<sup>1, 2, 3, 4</sup>Jayalakshmi Institute Of Technology

**Abstract-** Electric vehicles (EVs) require efficient battery management to ensure safety, reliability, and longevity. This project proposes a Smart Battery Monitoring and Protection System that continuously tracks critical battery parameters such as temperature, voltage, current, humidity, and fire hazards using sensors integrated with an Arduino Uno. If any parameter exceeds safe thresholds, the system triggers a relay to disconnect the EV motor. The IoT module enables real-time monitoring and alerts, allowing users to track battery status remotely through an online platform. This system enhances EV safety by preventing hazardous conditions, improving operational efficiency, and extending battery lifespan. By incorporating automated protection mechanisms and IoT-based monitoring, this solution provides a comprehensive and smart approach to battery management in electric vehicles. The project aims to contribute to the advancement of EV technology by offering a cost-effective, scalable, and reliable battery safety solution.

**Keywords:** Battery management system, BMS, Electric Vehicles, EVs, IOT, Internet of Things

## I. INTRODUCTION

The global transition toward sustainable transportation has significantly accelerated the adoption of electric vehicles. Central to the performance and safety of EVs is the battery system, which serves as the primary energy source. Lithium-ion batteries are widely used in EVs due to their high energy density, lightweight nature, and long cycle life. However, these batteries are highly susceptible to operating conditions such as overvoltage, over-current, excessive temperature, moisture exposure, and fire hazards. Failure to manage these parameters effectively can result in battery degradation, reduced efficiency, thermal runaway, or catastrophic failure. Traditional battery management systems (BMS) often focus on voltage and current balancing but may lack real-time environmental monitoring and remote accessibility. With the emergence of IoT technologies, it has become possible to continuously monitor battery health, transmit real-time data, and implement intelligent protection mechanisms. IoT-based monitoring not only enhances safety but also improves predictive maintenance and system

transparency. This paper proposes a smart, IoT-enabled battery monitoring and protection system using an ESP32 controller. The system integrates multiple sensors to monitor critical battery parameters and ensures automatic protection through load cut-off mechanisms. In addition to system implementation, this work also reviews existing battery monitoring approaches and highlights the advantages of integrating IoT with embedded systems for EV applications.

## Internet of Things (Iot)



Figure 1: Internet of Things (IOT)

The Internet of things (IoT) is the network of physical devices, vehicles, home appliances, and other items embedded with electronics, software, sensors, actuators, and connectivity which enables these things to connect, collect and exchange data. IoT involves extending Internet connectivity beyond standard devices, such as desktops, laptops, smartphones and tablets, to any range of traditionally dumb or non-internet-enabled physical devices and everyday objects. Embedded with technology, these devices can communicate and interact over the Internet, and they can be remotely monitored and controlled. With the arrival of driverless vehicles, a branch of IoT, i.e. the Internet of Vehicle starts to gain more attention.

The definition of the Internet of things has evolved due to convergence of multiple technologies, real-time analytics, machine learning, commodity sensors, and embedded systems. Traditional fields of embedded systems, wireless sensor networks, control systems, automation (including home and building automation), and others all contribute to enabling the Internet of things.

## II. PROBLEM STATEMENT

Conventional battery management systems used in electric vehicles often lack real-time monitoring and smart protection features. Overcharging, deep discharging, overheating, or environmental factors can cause irreversible battery damage, reduced efficiency, or potential hazards.

There is a need for a low-cost, intelligent solution that can monitor key battery parameters continuously and take immediate protective actions when unsafe conditions arise. Hence, this project focuses on developing an IoT-enabled battery monitoring and protection system that enhances the safety and reliability of electric vehicles.

## III. OBJECTIVES

The main objectives of this project are:

- To design a system that continuously monitors battery voltage, current, temperature, and humidity.
- To detect fire or overheating conditions and immediately trigger a safety relay.
- To implement IoT technology for real-time data monitoring through an online dashboard.
- To ensure automatic motor cut-off when unsafe battery conditions occur.
- To enhance battery life and ensure safe vehicle operation.
- To provide an economical and scalable solution for various electric vehicles.

## IV. SCOPE OF THE PROJECT

This project focuses on developing a smart, IoT-based monitoring and protection system for EV batteries. The system is capable of detecting abnormal parameters and sending alerts through the IoT platform. It provides a reliable and cost-effective solution for electric scooters, e-bikes, and other small to medium-sized EVs. The system can be further expanded to include advanced battery analytics, GPS tracking, and predictive maintenance features, making it suitable for industrial and commercial EV fleets.

## V. PROPOSED SYSTEM

The Smart Battery Monitoring and Protection System enhances electric vehicle (EV) safety, efficiency, and reliability using

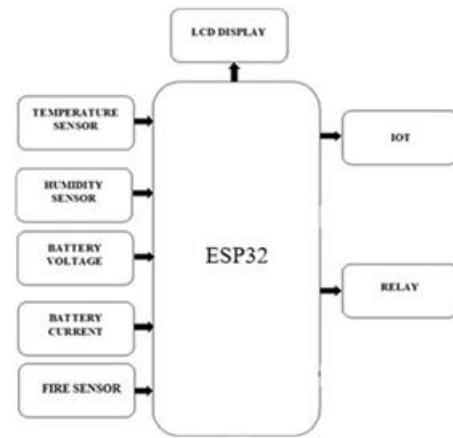

Figure 2: Proposed System Block Diagram

Arduino Uno, IoT, and sensor-based automation. The system continuously monitors key battery parameters such as temperature, voltage, current, humidity, and fire hazards. If any value exceeds the safe threshold, the relay automatically disconnects the EV motor, preventing damage or accidents. A battery lock sensor ensures security by detecting battery presence, preventing unauthorized removal. The relay-based charging system optimizes battery performance and extends lifespan. With an IoT module, users can remotely monitor battery status in real time and receive instant alerts on unsafe conditions. This system provides a cost-effective, automated, and intelligent solution for battery protection, efficient charging, and enhanced vehicle safety, making EVs more reliable and secure.

## VI. SYSTEM DESIGN

The proposed system follows a continuous monitoring and decision-making methodology. The ESP32 microcontroller serves as the central unit that acquires sensor data, processes it, and executes protection logic. Battery voltage and current are measured using the INA219 sensor, which provides high-accuracy digital readings through I<sup>2</sup>C communication. Temperature and humidity data are obtained from the DHT11 sensor, while a flame sensor detects potential fire hazards near the battery pack.

The collected data is compared with predefined safety thresholds stored in the microcontroller. If any parameter exceeds its permissible limit, the system triggers a relay to disconnect the load, thereby preventing damage or unsafe operation. Simultaneously, sensor data is transmitted to a cloud platform using Wi-Fi connectivity, allowing users to monitor battery status remotely. Alerts are generated in real time to notify users of abnormal conditions.

This methodology ensures rapid response, minimal human intervention, and continuous visibility of battery health, making it suitable for electric vehicle applications.

## VII. HARDWARE DESCRIPTION

The hardware architecture of the proposed Smart Battery Monitoring and Protection System is designed to ensure accurate sensing, reliable protection, and efficient data visualization. The ESP32 microcontroller is employed as the central control unit due to its high processing capability, low power consumption, and integrated Wi-Fi module, which enables seamless IoT connectivity.

Battery electrical parameters are monitored using the INA219 current and voltage sensor. This sensor measures the bus voltage and current flowing through the battery in real time using high-side current sensing and communicates with the ESP32 via the I<sup>2</sup>C protocol. The use of I<sup>2</sup>C communication minimizes wiring complexity while ensuring precise and synchronized data acquisition.

Environmental conditions affecting battery performance are monitored using the DHT11 sensor, which provides real-time temperature and humidity measurements. The sensor is positioned close to the battery pack to accurately capture thermal variations and moisture levels that may influence battery health and safety.

Fire hazards are detected using a flame sensor installed within the battery enclosure. This sensor provides a digital output indicating the presence of fire or sparks, enabling early detection of hazardous conditions.

A relay module is integrated into the system to provide electrical isolation and safe control of the battery load or EV motor. The relay is driven by the ESP32 through a digital output pin and is activated or deactivated based on the system's safety logic. When abnormal conditions are detected, the relay disconnects the load, preventing battery damage or safety risks.

For local monitoring and user interaction, an I<sup>2</sup>C-based 16×2 LCD display is incorporated into the system. The LCD is interfaced with the ESP32 using the I<sup>2</sup>C communication bus, sharing the same data and clock lines used by the INA219 sensor. This configuration reduces the number of GPIO pins required and enables efficient communication. The LCD displays real-time battery parameters, system status, and warning messages during fault conditions.

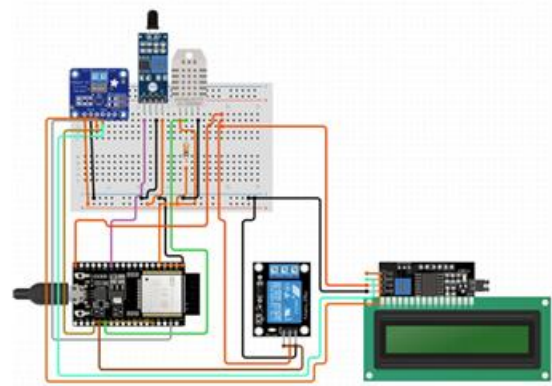

Figure 3: Hardware Circuit Diagram

## VIII. SYSTEM IMPLEMENTATION

The implementation of the Smart Battery Monitoring and Protection System involves coordinated operation of sensing, processing, display, communication, and protection mechanisms under the control of the ESP32 microcontroller. Upon system startup, the ESP32 initializes all connected peripherals, including the INA219 voltage and current sensor, the DHT11 temperature and humidity sensor, the flame sensor, the relay module, and the I<sup>2</sup>C LCD display. The I<sup>2</sup>C bus is configured to allow simultaneous communication with the INA219 sensor and the LCD display without data conflict. During normal operation, the ESP32 continuously acquires real-time voltage and current measurements from the INA219 sensor through the I<sup>2</sup>C interface. Simultaneously, temperature and humidity data are read from the DHT11 sensor, and fire status is monitored through the flame sensor's digital output. The acquired data is processed and compared against predefined safety thresholds stored in the system firmware.

The real-time battery parameters and operating status are displayed on the I<sup>2</sup>C LCD, providing immediate local feedback to the user. Under safe operating conditions, the relay remains energized, allowing uninterrupted power flow to the EV motor or load. Sensor data is also transmitted periodically to a cloud-based IoT platform using the ESP32's built-in Wi-Fi capability, enabling remote monitoring and data logging. When any monitored parameter exceeds its safe limit such as overvoltage, overcurrent, excessive temperature, high humidity, or flame detection—the ESP32 executes an immediate protection routine. The relay is deactivated, disconnecting the load from the battery supply. Concurrently, the LCD displays warning messages indicating the type of fault detected, and alert notifications are sent to the user through the IoT platform.

Once the fault condition is resolved and all parameters return to acceptable ranges, the system can be reset to resume normal operation. This integrated implementation ensures rapid response, reliable protection, real-time visualization, and remote accessibility, making the system suitable for intelligent battery management in electric vehicle applications. Results and Discussion The proposed system was tested under various operating conditions to evaluate its performance. Experimental results show that the INA219 sensor accurately measures voltage and current variations, enabling effective detection of abnormal electrical conditions. The DHT11 sensor successfully identifies temperature rise and humidity changes, while the flame sensor provides rapid detection of fire hazards.

The relay module responds promptly to fault conditions, disconnecting the load within milliseconds. IoT data transmission was found to be reliable, with real-time updates visible on the monitoring dashboard. The system demonstrated stable operation and accurate fault detection, confirming its suitability for EV battery protection. Compared to conventional battery monitoring systems, the proposed solution offers enhanced safety through multi-parameter sensing and remote monitoring. Its low cost and modular design make it adaptable to different EV platforms.

## IX. RESULT ANALYSIS

**Table 1: Result Analysis**

Parameter	Normal Condition	Abnormal Condition	System Response
Voltage > 10V	Safe	–	LCD shows SAFE

Parameter	Normal Condition	Abnormal Condition	System Response
Voltage < 10V	–	Low Voltage	Relay OFF, Alert ON
Temperature < 50°C	Safe	–	LCD shows SAFE
Temperature > 50°C	–	Overheat	Buzzer ON, Alert Message
Fire Sensor HIGH	Safe	–	Normal Operation
Fire Sensor LOW	–	Fire Detected	Alarm ON, Power Cut

The proposed system was tested under various operating conditions to evaluate its performance. Experimental results show that the INA219 sensor accurately measures voltage and current variations, enabling effective detection of abnormal electrical conditions. The DHT11 sensor successfully identifies temperature rise and humidity changes, while the flame sensor provides rapid detection of fire hazards. The relay module responds promptly to fault conditions, disconnecting the load within milliseconds. IoT data transmission was found to be reliable, with real-time updates visible on the monitoring dashboard. The system demonstrated stable operation and accurate fault detection, confirming its suitability for EV battery protection. Compared to conventional battery monitoring systems, the proposed solution offers enhanced safety through multi-parameter sensing and remote monitoring. Its low cost and modular design make it adaptable to different EV platforms.

## X. CONCLUSION

The project —Smart Battery Monitoring and Protection System for Electric Vehicles Using IoTI has been successfully designed and implemented to ensure the safety, efficiency, and reliability of electric vehicle battery operations. The system continuously monitors essential parameters such as voltage, current, temperature, humidity, and fire detection, providing real-time insights to the user through both LCD display and an Android-based IoT application. The proposed system effectively detects abnormal battery conditions such as overvoltage, overheating, or fire hazards and immediately takes protective actions by triggering a relay cut-off and alarm notification. This automatic protection mechanism prevents damage to the battery pack and ensures user safety. The integration of IoT technology allows users to remotely monitor battery health, receive instant alerts, and maintain the vehicle's operational efficiency. The experimental results show that the system responds rapidly to unsafe conditions and accurately displays real-time data, demonstrating its reliability and practicality for electric vehicle applications. Furthermore, it is cost-effective, scalable, and energy-efficient, making it suitable for both small-scale and commercial EVs. In conclusion, this project provides a smart, automated, and IoT-enabled battery management solution that enhances the performance and safety of electric vehicles. It also contributes to the growing field of smart transportation systems by integrating embedded systems with modern communication technologies, paving the way for future advancements in sustainable mobility and green energy solutions.

## REFERENCES

Advanced Computer Science and Applications (IJACSA),  
Vol. 12, Issue 9, 2021.

- [1] Raj Kamal, Embedded Systems: Architecture, Programming and Design, Tata McGraw Hill Education, 2011.
- [2] Muhammad Ali Mazidi, Janice Gillispie Mazidi, and Rolin
- [3] D. McKinlay, The 8051 Microcontroller and Embedded Systems, Pearson Education, 2012.
- [4] Simon Monk, Programming Arduino: Getting Started with Sketches, McGraw-Hill Education, 2016.
- [5] Clarence W. de Silva, Mechatronics: An Integrated Approach, CRC Press, 2008.
- [6] P. Venkataraman, Applied Optimization with MATLAB Programming, Wiley Publications, 2009.
- [7] D. S. Kumar and P. Suresh, —IoT-Based Smart Battery Management System for Electric Vehicles,| International Journal of Advanced Research in Electrical, Electronics and Instrumentation Engineering (IJAREEIE), Vol. 9, No. 6, 2022.
- [8] A. Kumar, R. Mehta, and S. Sharma, —Design and Development of IoT Enabled Battery Monitoring System,| IEEE International Conference on Smart Energy Systems, 2021.
- [9] R. Singh and P. Yadav, —Intelligent Battery Management System for Electric Vehicles Using IoT,| International Journal of Innovative Technology and Exploring Engineering (IJITEE), Vol. 10, Issue 5, 2021.
- [10] K. Deepa and M. N. Gopinath, —IoT-Based Temperature and Voltage Monitoring in EV Battery Systems,| Journal of
- [11] Emerging Technologies and Innovative Research (JETIR), Vol. 8, Issue 3, 2022.
- [12] P. Karthikeyan and R. Dinesh, —Real-Time Monitoring and Control of EV Battery Parameters Using Arduino,| International Journal of Engineering Research & Technology (IJERT), Vol. 10, Issue 9, 2021.
- [13] N. Shankar et al., —Smart BMS Using Embedded System and IoT,| IEEE Transactions on Industrial Electronics, Vol. 68, No. 7, 2021.
- [14] R. Gupta and S. Pandey, —Design of an IoT-Based Fire Detection and Safety System,| International Research Journal of Engineering and Technology (IRJET), Vol. 9, Issue 4, 2022.
- [15] T. Lee and M. Chen, —Real-Time Wireless Monitoring System for Electric Vehicle Batteries,| Sensors Journal, IEEE, Vol. 18, No. 6, 2020.
- [16] R. Venkatesan and A. John, —Cloud-Based Energy Monitoring and Protection System,| International Journal of Science and Research (IJSR), Vol. 11, Issue 2, 2023.
- [17] D. Patel and J. Thomas, —Microcontroller-Based Smart Battery Charger Using IoT,| International Journal of