

Solar And Wind-Based Smart Street Lighting With Wireless Charging For Electric Vehicles And Power Generation Using Speed Breakers

Prof. Quereshi.A.A¹, Bidve Chaitnya², Panchal Gaurav³, Kolhe Hanmant⁴, Chothave Tejas⁵

^{1, 2, 3, 4, 5} Dept of Electrical Engineering,

^{1, 2, 3, 4, 5} Vishweshwarayya Institute Of Engineering And Technology, Dilip Nagar, Almala Tq. Ausa Dist. Latur - 413556,

Abstract- The project “Solar and Wind-Based Smart Street Lighting with Wireless Charging for EVs and Power Generation Using Speed Breakers” presents a hybrid renewable energy system that combines solar, wind, and mechanical energy sources. A 12V solar panel with an MPPT controller generates power during the day, while wind turbines provide energy at night or during low sunlight conditions. Additional power is produced using piezoelectric sensors installed under speed breakers, converting vehicle pressure into electricity.

All generated energy is stored in a rechargeable battery and used for smart street lighting and wireless EV charging through Dynamic Energy Transfer (DET). The system also includes an Arduino-based monitoring setup with an LCD display. This integrated approach improves energy efficiency, ensures continuous power supply, and supports sustainable smart city infrastructure.

Keywords: Component, formatting, style, styling, insert.

I. INTRODUCTION

In recent years, the world has witnessed a significant rise in energy consumption due to rapid industrialization, urbanization, and population growth. Traditional energy sources such as coal, petroleum, and natural gas are not only depleting but also contribute heavily to environmental pollution and global warming. This has created an urgent need to shift toward renewable and sustainable energy systems.

Street lighting is an essential part of urban infrastructure, consuming a considerable amount of electrical energy. Conventional street lighting systems depend entirely on grid power, leading to high operational costs and increased carbon emissions. Similarly, the increasing adoption of electric vehicles (EVs) has created a demand for efficient and innovative charging solutions.

At the same time, a large amount of energy is wasted in the form of mechanical vibrations generated by moving vehicles on roads. This untapped energy can be converted into useful electrical energy using modern technologies like piezoelectric transducers.

II. RESEARCH METHODOLOGY

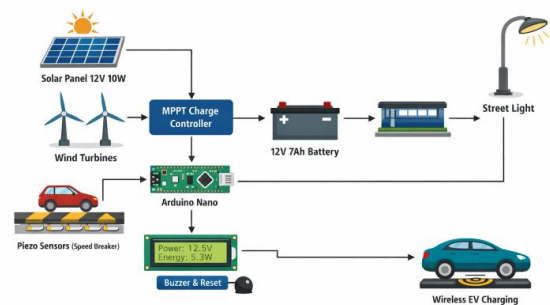

III. METHODOLOGY

This chapter explains the overall methodology used in the design and implementation of the project “Solar and Wind-Based Smart Street Lighting with Wireless EV Charging and Power Generation Using Speed Breakers.”

The system integrates multiple energy sources such as solar, wind, and piezoelectric energy to generate electricity, store it, and utilize it for street lighting and EV charging. The methodology includes system architecture, block diagram, working principle, and detailed hardware description. +4

Software & Control Logic

Manual Mode: Controlled via an Android App using a Bluetooth (HC-05) or Wi-Fi (ESP32) module.

Autonomous Mode: The robot follows a predefined path while using ultrasonic sensors to avoid obstacles. For

irrigation, the pump activates automatically if the soil moisture sensor falls below a programmed threshold (e.g., <30%).

This section elaborates the proper statistical/econometric/financial models which are being used to forward the study from data towards inferences. The detail of methodology is given as follows.

IV. LITERATURE REVIEW

Literature Review

A literature review is an essential part of any engineering project, as it provides an understanding of existing technologies, methodologies, and research developments related to the proposed system. This chapter presents a comprehensive review of research papers related to:

- Hybrid solar-wind street lighting systems
- Piezoelectric energy harvesting from roads
- Renewable energy integration
- Smart energy management systems
- Wireless energy transfer for EVs

The objective is to analyze previous work, identify limitations, and justify the need for the proposed system. Small-Scale Optimization: Unlike commercial robots like FarmDroid FD20, which are targeted at large industrial farms, recent research (e.g., MARS system, 2026) focuses on lightweight (<4kg), low-cost (<₹20,000) solutions specifically for plots under one acre.

List of Component's :-

- **Solar Panel (12V, 10W)**
- **MPPT Solar Charge Controller**
- **Wind Turbine (2 Units)**
- Piezoelectric Transducers (6 Nos, 35mm)
- **Arduino Nano**
- LCD Display (16×2 with I2C)
- **Buzzer and Reset Button**
- **12V 7Ah Battery**

Result and Discussion :-

The developed system of Solar and Wind-Based Smart Street Lighting with Wireless EV Charging and Power Generation Using Speed Breakers was successfully designed and tested at a prototype level. The integration of multiple energy sources—solar panel, wind turbines, and piezoelectric

sensors—resulted in a functional hybrid energy generation system.

The solar panel generated electrical energy efficiently during daytime conditions, while the wind turbines contributed additional power during low sunlight or nighttime. The piezoelectric sensors installed under the speed breaker successfully generated small amounts of electrical energy when pressure was applied by moving vehicles. This demonstrated the feasibility of harvesting mechanical energy from road traffic.

V. CONCLUSION

- This project successfully demonstrates an innovative approach to energy generation and utilization by integrating solar, wind, and piezoelectric technologies into a single system. The hybrid model ensures better reliability and continuity of power supply compared to conventional single-source systems.
- The use of renewable energy sources makes the system environmentally friendly and sustainable. The addition of piezoelectric energy harvesting introduces a novel way to utilize otherwise wasted mechanical energy from vehicles. The implementation of smart street lighting further enhances energy efficiency by reducing unnecessary power consumption.
- The wireless charging feature for electric vehicles represents a forward-looking solution aligned with modern transportation needs. Although still in the developmental stage, it shows strong potential for future applications.
- Despite some limitations such as initial cost, low output from piezoelectric sensors, and lower efficiency of wireless charging, the system provides a strong foundation for future smart energy solutions. It is especially useful in smart cities, highways, and remote areas.
- In conclusion, the project achieves its objectives and presents a practical, eco-friendly, and scalable solution for modern energy challenges.

Software requirement

This chapter describes the software requirements and tools used in the development of the project “Solar and Wind-Based Smart Street Lighting with Wireless EV Charging and Power Generation Using Speed Breakers.”

The software plays a crucial role in controlling, monitoring, and processing the signals generated from various components, especially the piezoelectric sensors and system

outputs. The central software platform used in this project is the Arduino IDE, which is used to program the microcontroller (Arduino Nano).

Programming Languages

Embedded C/C++: The standard language for defining robot control logic, hardware interactions, and real-time task sequencing.

Advantages :-

- Use of Renewable Energy Sources
- Hybrid Energy Generation System
- Energy Harvesting from Speed Breakers
- Energy Efficient Street Lighting
- Wireless Charging for Electric Vehicles
- Environment Friendly System
- Low Operating Cost

Disadvantages:-

- High Initial Cost
- Low Output from Piezoelectric Sensors
- Dependence on Environmental Conditions
- Complexity of System Design
- Maintenance of Multiple Components
- Wireless Charging Efficiency
- Limited Battery Capacity
- Installation Challenges

Appllication :-

Smart Street Lighting Systems

- Highways and Roads
- Smart Cities
- Electric Vehicle Charging Stations
- Toll Booths and Parking Areas