

# Three Phase Transmission Line Fault Detection And Analysis System

Aditya P. Badgujar<sup>1</sup>, Gaurav R. Sharma<sup>2</sup>, Tushar S. wadhe<sup>3</sup>, Rahul P. Hiwale<sup>4</sup>,  
Anand S. Hirole<sup>5</sup>, Ankush R. Gaikwad<sup>6</sup>, Pawan S. Mali<sup>7</sup>, M.R.Wankhade<sup>8</sup>

<sup>1,2...8</sup> Dept of Electrical Engineering

<sup>1,2...8</sup> Padm.Dr.V.B.K.College of Engineering, Malkapur, Buldhana, India.

**Abstract-** The Electric Power System is categories into many different sections. One from that is the transmission system, where power is transmitted from generating stations to substations via transmission lines into consumers. Both methods could operate various types of malfunctions is usually referred to as a "Fault". Fault is simply defined as a number of undesirable but unavoidable incidents can temporarily disturb the normal condition of the power system that occurs when the insulation of the system damaged at Particular point. Moreover, if a Conducting object comes in contact with a open power conductor, a short circuit, or fault, is said to have happened. The causes of faults are many, and they include lighting, wind damage, trees falling across transmission lines ,line fall on building, vehicles or aircraft colliding with the transmission towers or poles, birds shorting lines or vandalism. In this study, the causes and effects of faults in the overhead transmission lines was the focus of the research. Some of the many reason of faults and some located methods will be discussed. These faults lead to substantial damage to the power system equipment and high voltage In India it is common, the faults might be LG (Line to Ground), LL (Line to Line), 3L (Three lines) in the normal supply systems and these faults in three phase supply system can be affect the power system

**Keywords-** Fault Classification, Fault Detection, Transforms, Three Phase , Microprocessor.

## I. INTRODUCTION

The Fault occurrence in power systems could result in losing their stability and cause severe damages in faulted devices or adjacent healthy a devices. Also, stability Proposition is charge as an important component in energy management and the planning of power systems [1]. Moreover, during the motor starting period, it is draws a large current from the system, results in voltage drop of system and poses the disturbances to the normal operation of other loads. Various studies have shown that ananywherefrom70%,to as highas90%, the of faults on most overhead lines are transient. A transient fault, such as the an insulator flashover, is a fault which is cleared by the immediate tripping of one or as more circuit breakers to isolate the fault, and which does not recur when the line is re-

energized. Faults tend to be less transient (near the 80% range) at lower, distribution voltages and more transient (near the 90% range) at higher, sub transmission and the transmission voltages.[2] Lightning is the most common cause of transient faults, partially resulting from insulator flashover from the high a transient voltages induced by the lightning. Other possible causes are swinging wires and temporary contacts with foreign objects. The Thus, transient faults can be cleared by momentarily de-energizing the line, in order to allow the fault to clear. Auto reclosing can then restore service to the line. The remaining 10 - 30% of the faults are semi-permanent or permanent in nature. A small branch falling onto the line can cause a semi-permanent fault. In this case, however, an immediate the de-energizing of the line and subsequent auto reclosing does not clear the fault. I an instead, a coordinated time- delayed trip would allow the branch to be burned away without damage to the system. Semi-permanent faults of this type are likely to be most prevalent in highly wooded areas and can be substantially controlled by aggressive line clearance programs [3]. Permanent faults are those that will not clear upon tripping and reclosing. An example of a permanent fault on an overhead line is a broken wire causing causes a phase to open, or a broken pole causing the phases to short together. Faults on underground cables should be considered permanent. Cable faults should be cleared without auto reclosing and the damaged a cable repaired before service is restored. There may be exceptions to this, as in the case of circuits composed of both underground cables and overhead lines this de-energized line long enough for the fault source to pass and the fault an arc to de-energize, then automatically recloses the line to restore service. Thus, auto reclosing the can significantly reduce the outage time due to faults and provide a higher level of service continuity to the customer. Furthermore, successful the high-speed reclosing auto reclosing. On transmission circuits can be was a major factor when attempting to maintain system stability. For those faults that are permanent, an auto reclosing will reclose the circuit into a fault that has not been cleared, which they may have adverse effects on system stability.[1]

## Nature and Causes of Faults

Nature of a fault is simply defined as any abnormal condition, which causes a the reduction in the basic insulation strength between phase conductors, or between phase conductors and earth or any earthed screens surrounding the conductors. an In practice, a reduction is not regarded as a fault until is it is detectable, that is until it results either in an excess current or in a reduction of the impedance between conductors, or between conductors the and earth, to a value below that of the lowest load impedance normal to the circuit. are Thus a higher degree of pollution on the an insulator string, although it reduces the insulation strength of the affected phase, does not become a fault until it causes a flashover across an the string, which in turn produces excess current or other detectable abnormality, for the example abnormal current in an arc-suppression coil [4].

**1.1 Lightning**

More than half of the electrical faults occurring the on overhead power transmission lines are caused by lightning (seeFigure2.1). The main conventional approaches for reduction of the lightning flashover faults on an power lines are lowering of the footing is resistance and employing of multiple shielding wires, and differential insulation. However, these methods have not been sufficient to prevent flashover faults. an In the meantime application of arresters to lines has been a better solution in the recent years. This alternate approach is to install an arrester to prevent the flashover of insulator assemblies A newly developed suspension-type line an arrester has been developed by incorporating ZnO elements into the shed of a the conventional suspension insulator (Figures 2 and 3). It has an arrester function along with the normal electrical and mechanical functions of a line insulator. It is the gapless type that has the advantage of reliable surge absorption with no delay in discharge. The new is arrester holds promise not only for the prevention of fault but also as means of achieving economical insulation in the overall transmission systems [2].

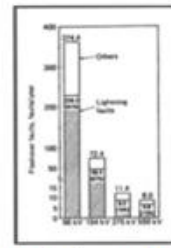

**Fig 1: Flashover faults on Transmission line**

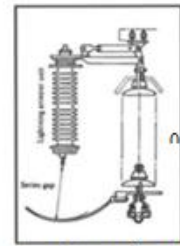

**Fig 2: Configuration of LA**

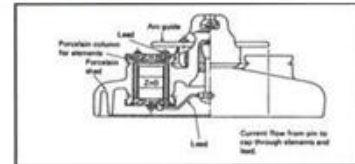

**Fig3: Lightning Arrester Unit with ZnO**

1.2 Types of faults .

- 1) 1.2.1 Shunt faults:
  - Single line-to-ground faults
  - Line-to-line faults
  - Double line-to-ground faults
- 2) 1.2.2 Series faults
  - a) One line open
  - b) Two line open

Power system faults may be categorized as shunt faults and series faults. The most occurring type of shunt faults is Single Line-to- ground faults (SLG), which one of the four types of shunt faults, which occur along the power lines. This type of fault occurs when one conductor falls to ground or contacts the neutral wire. It could also be the result of falling trees in a winter storm. This type could be represented as in figure 4[3].

Second most occurring type of shunt faults is the Line-to-Line fault (LL).It is the result of two conductors being short-circuited. As in the case of a large bird standing on one transmission line and touching the other, or if a tree branch fall on top of the two of the power lines. This type could be represented as in Figure 5 [4].

Third type of fault is the Double Line-to-Ground fault (DLG), Figure 6. This can be a result of a tree falling on two of the power lines , or theirs causes. The fourth hand least occurring type of fault is the balanced three phase (figure 7), which can occur by a contact between the three power lines in many different forms.

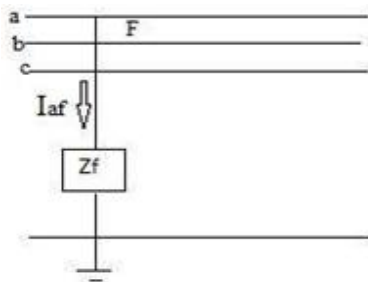

**Fig4: Single Line-to-Ground Fault**

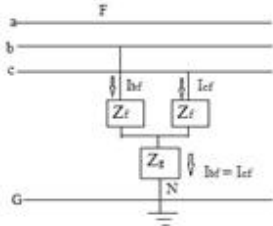

**Fig 6: Double Line-To-Ground Fault**

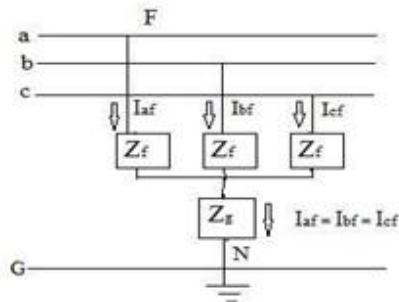

**Fig7: Three phase Fault**

Series faults can occur along the power was lines as the result of an unbalanced series impedance condition of the lines in the case of one or two broken lines for example. In predictive, a series fault is encountered, for example, when lines (or circuits) are controlled by circuit breakers (or fuses) or any device that does not open all three phases; one or two phases of the line was (or the circuit) maybe open while the other phases or phase is closed [1].

**II. FAULT DETECTION**

**2.1 Fault Detection Using Composite Fiber-Optic**

In electric power supply services, power transmission lines are very impose rant and very in dispensable. For that, power transmission lines are is equipped with various protection systems that are check varies times periodically because of the unexpected troubles that may destroy the lines. For the purpose of protecting these lines, a new system was invented to discover the Fault Location using Composite Fiber Optic Overhead Ground Wire (OPGW). This system deals

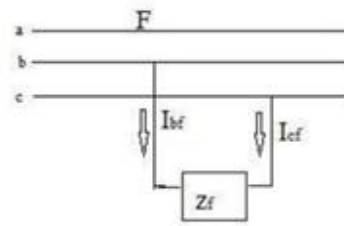
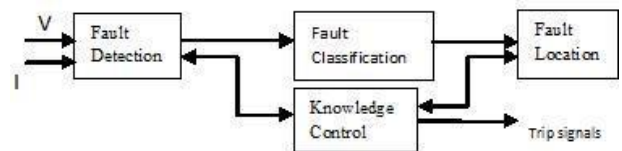

**Fig5: Line-to-Line Fault**

mainly with most causes of fault situation was such as lightning, This is , snow ,fog ,or gales. This new fault location system was developed to find out where electrical fault was it happened on overhead power transmission lines by detecting the current induced in the ground wire. Any fault situation needs the fastest processing in fixing the fault. For that, the fault location system helps engineers to detect the point or the section where an electrical fault that pending very logic time [2].

Since, was the fault information is uncertain is n, the new fault location deals with that the fault information as a current distribution pattern throughout the power line, and applies Fuzzy Theory to realize the human-like manner of fault used by power engineers. So the fault information system is mainly given by sensing and data transmission. Electrical faults occurring on power transmission lines can be classified into two types: ground in short circuit fault.

The transmission that gets to the central monitor station deals with current characteristic features [3].



**Fig8: The functional parts of Protective Relay**

**2.2. Fault Detection Using Neural Network**

As indicated before, protecting transmission is very important task in safe guard electric power systems. For that, faults on transmission lines need to be detected, class infield, and located accurately. All these actions must be taken in very short time to clear the fault. The new approach of neural network to fault classifications for high speed protective relaying is a good manner in solving any fault classification for high speed protective relaying is a good manner in solving any fault happened toys the transmission lines. Mainly this scheme is based on the use of neural architecture and

implementation of digital signal processing concepts. Figure 8 shows functional so parts of protective relay. The protective relay need sampled values of currents and voltages of three lines build inputs of the system. In general, a knowledge control module controls all other parts of the relay and is responsible for sending trip signals. This module classifies weather a 1-phase-to-ground, 2-phase-to-ground, phase-to-phase or a 3-phahose fault has occurred. In the classification process, arcing and non-arcing must be known in order to obtain a successful automatic reclosing. Generally speaking, neural network classifies the fault into types. The first type (1-phase, 2-phase, 3-phase faults ) is fast 5-7 may and reliable. The second type, arcing and non-arcing faults support a successful automatic reclosing [2].

**III. REVIEW PROCESS ADOPTED**

A literature review is necessary to know about the research area and what problem in that of area has been solved and need to be solved in future. This review process approach was divided into five stages in order the so make the process simple and adaptable. The stages are defined as:-

Stage 0: Geta “feel”

This stage provides the details to be checked while starting literature survey with a broader domain and classifying them according to requirements.

Stage1:Get the“ big picture”

The group so research paper say group prepare according to common issues & application sub areas. It is necessary to find out the answers to certain questions by reading the Title, Abstract, introduction, conclusion and section and sub section headings. the scroll down window on the left of the MS Word Formatting toolbar.

Stage2: Get the “details”

Stage 2 deals with going in depth of each research paper and understand the details of methodology used to justify the problem, justification to significance & novelty of the solution approach, precise question addressed, major contribution, scope & limitations of the work presented.

Stage3: “Evaluate the details”

This stage evaluates the details in relation to significance of the problem, Ntrovelty of the problem, significance of the solution, novelty in approach, validity of claims etc.

Stage4: “Synthesis size the detail”

Stage 3: radials with evaluation of the in details presented and generalization to some extent. This stage deals with synthesis of the data, by concept & the results presented by the authors.

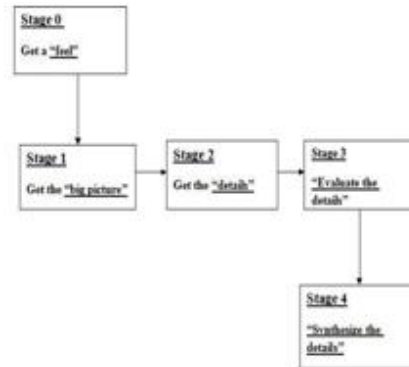

Fig.9: Review process adopt

**IV. OVERVIEW OF NETWORK SEQUENCES**

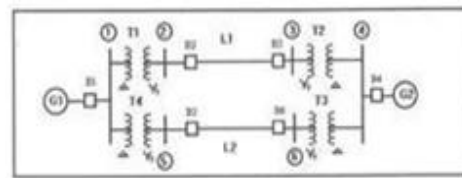

Fig10: Any fault occurring transmission line

**4.1 Working principle**

The term uses numbers step-down transformers for handling the entire circuit under low voltage conditions of 12v only to test the 3 phase fault analysis. The primaries of 3 transformers are connected to a 3 phase supply in star configuration, while the secondary of the same is also connected in star configuration. The other set if 3 transformers with its primary connected in star to 3 phases have their secondary’s connected in delta configuration. The outputs of all the 6 transformers are rectified.

Table1: System Data (used for figure 10).

Network component	MVA rating	Voltage rating (kV)	X1 (pu)	X2 (pu)	X0 (pu)
G1	200	20	0.2	0.12	0.06
G2	200	13.2	0.37	0.25	0.08
T1	200	20/230	0.2	0.2	0.2
T2	200	13.2/230	0.225	0.225	0.225
T3	200	20/230	0.27	0.27	0.27
T4	200	13.2/230	0.16	0.16	0.16
L1	200	230	0.11	0.11	0.25
L2	200	230	0.33	0.33	0.6

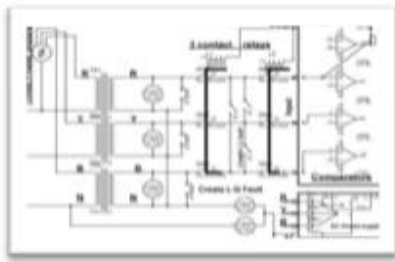

Fig 11 (a): Schematic diagram of 3 phase fault analysis.

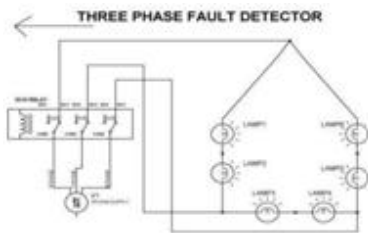

Fig 11(b): Proposed Schematic diagram of 3 phase fault analysis and filter individually and are given to relay coils.

push buttons, one each connected across the relay coils meant to create a fault condition either at star i.e. Fault or 3L Fault. The NC contacts of all the relays are made parallel while all the common points are grounded. The parallel connected point of NC are given to pin 2 through resistor R5 to aid 555 timer i.e. wire no stable mode. The output of the same timer is connected to the reset pin4 of another 555 timer wire dim-stable mode. LED' Sure the connected at their output to indicate their status. The output of the U3 ou555timer frompin3 is given to an Op-amp LM358 through wire 11 and d12to the non inverting input pin3, while the inverting input is kept at a fixed voltage byapotentialisdividerRV2.Thevoltageatpin2cominghf fromthe potential divider is so held that it is higher than the pin3 of the Op-amused as a comparator so that pin1 develops zero logic that fails to operate the relay through the driver transistor Q1.[2] This relay Q1 is '3CO' relay i.e.is was. is meant for disconnecting the load to indicate fault conditions.

4.2 Hardware Testing

4.2.1 Conductivity Test.

In electronics, a continuity test is the checking of an electric circuit to see if current flows (that it is in fact a complete circuit). A continuity test is performed by placing a small voltage (wired in series with an LED or noise-producing component such as a piezoelectric speaker) across the chosen path. If electron flow is in habited by broken conductors, damaged components, or excessive resistance, the circuit is "open".[3] Devices that can be used to perform continuity test sins millimeters which measure current and specialized

continuity testers which are cheaper, more basic devices, generally with a simple light bulb that lights up when current flows.

4.2.2 Power ON Test

This test was performed to check whether the voltage at different terminals is according to the requirement or not. We take a multi meter and put it in voltage mode. Remember that this test is performed by without ICs. Firstly, if we are using a transformer we check the output of the transformer; whether we get the required 12V AC voltage (depends on the transformer used in for the circuit). If we use a battery then we check if the battery is fully charged or not according to the specified voltage of the battery by using millimeter.

This particular field, the fault analysis and detection techniques can be used are given in following:

1. Fault Detection using Composite Fiber optic
2. Fault Detection using Neural Network
3. The concept in the future can be extended to developing

a mechanism to send message to the authorities viaSMS by interfacing a GSMhg modem. By using Microcontroller % error between the actual and obtained distances is calculated as [4].

$$\%Error = \frac{4 \text{ Calculated Distance} - \text{Actual Distance} * 100}{\text{Actual Distance}}$$

V. CONCLUSIONS

This study shows about the earth fault carried out for various locations along the overhead transmission line for various types of the faults. In this overhead transmission are classified line four types of fault namely L-G, 2L-G, 3L-G and three phase faults have been Distance taken at 250 km into consideration into work and here four fault namely as single line ground fault, Double line to ground faults, Triple line to ground faults and L- L-L faults are comparison and detection has been show by this study with their proposed work.

According, to the results, the current magnitude of the fault is increased and voltage drop of existing buses at the moment of starting is decreased in together conversion of entire network.

Therefore, when designing the power transmission systems, electric companies are expected to follow the set of standard specifications that are briefly described in chapter two of this research, keeping in mind that the further away

transmission lines are polychrome natural elements, such as trees, the less faults occurrences will be and the more reliable the power system will be.

## VI. ACKNOWLEDGMENTS

We would like to express our deep gratitude and thanks to Mr. M.R.Wankhade (lecturer) Padm.Dr.V.B.K.Coe, Malkapur. giving us an opportunity to work under his guidance for our review of research papers and his consistent motivating & direction in this regard. We extend our sincere thanks to Mr. Manoj Wankhade lecturer, Padm.Dr.V.B.K.Coe, Malkapur for his continuous support and encouragements throughout the course work. Last but not least I would like to thank my parents & family who always inspired and directed me. I would like to thank the all (Principal, Hod ,Faculty members) people who were involved directly or indirectly to complete our review paper work.

## REFERENCES

- [1] <https://ijari.org/assets/papers/5/2/IJARI-EE-17-06-102.pdf>
- [2] [https://www.academia.edu/36471653/Transmission\\_Line\\_Protection\\_device\\_with\\_Auto\\_Reset\\_for\\_Temporary\\_Fault\\_and\\_Trip\\_for\\_Permanent\\_Fault](https://www.academia.edu/36471653/Transmission_Line_Protection_device_with_Auto_Reset_for_Temporary_Fault_and_Trip_for_Permanent_Fault)
- [3] [https://www.academia.edu/36471653/Transmission\\_Line\\_Protection\\_device\\_with\\_Auto\\_Reset\\_for\\_Temporary\\_Fault\\_and\\_Trip\\_for\\_Permanent\\_Fault](https://www.academia.edu/36471653/Transmission_Line_Protection_device_with_Auto_Reset_for_Temporary_Fault_and_Trip_for_Permanent_Fault)
- [4] <https://www.scribd.com/document/98099023/Paper-on-Automatic-Reclosing-Transmission-Lines-Applications-and-Its-Considerations>
- [5] [https://www.researchgate.net/publication/321097011\\_AUTOMATIC\\_FAULT\\_DETECTION\\_AND\\_PROTECTION\\_OF\\_THREE\\_PHASE\\_INDUCTION\\_MOTOR#:~:text=A%20transient%20fault%2C%20such%20as,the%20line%20is%20re%2Denergized.](https://www.researchgate.net/publication/321097011_AUTOMATIC_FAULT_DETECTION_AND_PROTECTION_OF_THREE_PHASE_INDUCTION_MOTOR#:~:text=A%20transient%20fault%2C%20such%20as,the%20line%20is%20re%2Denergized.)
- [6] <https://www.bing.com/ck/a?!>
- [7] <https://www.coursehero.com/file/106570960/transmission-fault-detection-reportdocx/>
- [8] <https://electrical-engineering-portal.com/download-center/books-and-guides/relays/calculation-short-circuit-currents>
- [9] <https://studylib.net/doc/17545161/1-chapter-one-introduction>
- [10] <https://ijireeice.com/wp-content/uploads/2018/04/IJIREEICE-19.pdf>