

Seismic Retrofitting of R.C. Structures

Jitesh Vithoba Hiware¹, Prof. Harshwardhan Rangari², Prof. Girish Savai³

^{2,3} Assistant Professor

^{1,2,3} V.M. Institute of Technology, Nagpur

Abstract- Recent earthquakes that occurred during last ten years have suggested that significant damage happened wasn't specifically on account of methods of earthquakes but on account of bad performance of construction during earthquake. The current building system, that were design and constructed according to first codal provisions, don't satisfy needs of present seismic design and code methods. It's realized that the best technique of lowering the danger of harmful structure is seismic retrofitting. In the recent past, there's a tremendous enhancement of retrofitting techniques. This analysis highlights the concepts of evaluating and also retrofitting of structure against seismic events. A 3 dimensional R.C. frame fashioned with linear elastic compelling analysis. The computer software program ETab is utilized for dynamics analysis strategy is applied to look at the functionality of a reinforced concrete building. The various retrofitting techniques including steel and concrete application and jacketing of fibre reinforced polymer (FRP) composites that happened to be utilized to enhance the load bearing capacity of specific structure elements are highlighted and techniques including shear wall space plus shear cores that enables you to improve general balance of buildings. Most retrofitting techniques are going to result a rise in stiffness as well as somewhat enhance in mass that causes in return a shorter period. Shortening in period of vibration quite often results an increased ductility and strength of retrofitted structure. Consequently, a proposed retrofit program could be believed to achieve success in case it results an increased strength and also ductility capability of the structure that is higher compared to the requirements required by earthquakes.

Keywords- Retrofitting, Seismic Events, FRP, Jacketing, Stiffness.

I. INTRODUCTION

1.1 GENERAL

In the past thirty years, moderate to severe earthquakes occurs around the world every year. Such events lead to damage to the concrete structures as well as failures. Thus, the aim is to Focus on a few specific procedures which may improve the practice for the evaluation of seismic vulnerability of existing reinforced concrete buildings of more

importance and for their seismicretro fitting by means of various innovative techniques such as base isolation and mass reduction. So Seismic Retrofitting is a collection of mitigation technique for Earthquake engineering. It is of utmost importance for historic monuments, areas prone to severe earthquakes and tall or expensive structures.

The existing building stock poses a much more serious and complex seismic safety problem when compared to safe earthquake design of new construction. The vast majority of structures located in seismic areas exhibit deficiencies in their resistance to earthquake loads due to a number of reasons, highlighted below.

Older construction, designed according to earlier codes, may not comply with current seismic regulations since focus used to be primarily on warranting sufficient capacity for gravity loads alone. Moreover, the past thirty years have witnessed such a significant increase of knowledge in the field of earthquake engineering that even relatively modem structures may no longer meet the prerequisites of constantly-developing regulations. As a result, several shortcomings can be found in existing buildings such as irregular structural configuration, inappropriate member detailing for ductility and insufficient lateral stiffness, amongst others.

All the above considered, it seems clear that repair and strengthening of both old structures designed according to outdated codes and new but defective earthquake-resistant construction, is urgently needed. This requirement also arises where existing structures must comply with more recent code stipulations, or when these structures are to be reassessed for higher loads.

Further, precise structural assessment quite often stumbles on the unavailability of accurate design plans and the uncertainties regarding material properties, particularly in the case of old structures. In the case of earthquake-hit structures, evaluation of the level of damage can be difficult on occasions, and assumptions based on engineering judgment, rather than codified guidelines, are needed. The superior performance characteristics of new materials, such as fiber-reinforced polymers, may also be exploited. However, some of these highly efficient interventions are expensive (due to the production cost associated to such novelty materials) and

require skilled workmanship. This often constitutes a big impediment in the majority of poorer earthquake-prone countries, and the use of familiar construction methods making use of traditional materials, such as steel and concrete, is a preferable solution.

In the case of reinforced concrete (RC) structures, the aforementioned difficulties constitute a particularly serious problem. This type of construction is widely used for critical public buildings, such as schools, hospitals, fire stations and public administration offices, amongst others. Also, this class of structures is commonly associated to large occupancy buildings such as multi-storey residential blocks, offices and hotels. However, despite the importance in safeguarding the seismic behaviour of such sensitive structures, there is very little codified criteria and guidelines for assessment and structural upgrading of RC buildings

The problem, however, becomes more intricate when other factors, beyond the reach of regulations, are taken into account. In fact, it is frequent for existing buildings to have suffered structural modifications applied by their owners without due engineering consideration, thus further hindering what may already be a low seismic resistance. Also, quality of construction may be poor, resulting in a defective design-implementation. The latter may lead to disastrous consequences, as recently highlighted by the devastation and human casualties resulting from the Kocaeli (Turkey) of 17 August 1999 and, to a lesser extent, the North Athens (Greece) earthquake of 7 September 1999.

There are three key concepts in seismic design that were fully developed by researchers and engineers. First, earthquake ground motions generate inertial loads that rapidly change with time. Thus, it is common that calculations include a term labeled with a unit of time (usually seconds) and these terms include periods of vibration or their inverse, frequencies; accelerations and velocities. In many other structural engineering problems such as calculations of gravity loads, no unit of time is used.

CHOICES FOR THE LATERAL FORCE-RESISTING ELEMENTS OF STRUCTURAL SYSTEMS

The choices of lateral-force-resisting systems in buildings are limited to the following, with very few exceptions: braced frames (vertically-oriented truss elements), moment-resistant frames, shear walls, diaphragms and response modification techniques that change the seismic demand on the lateral-force-resisting elements. Such techniques focus on changing the forces in the structure due to ground motion (e.g. seismic isolation) or changing the

displacement within the structure due to the ground motion (e.g. damping devices). The materials, of which these elements can be made, with very few exceptions, are limited to: steel (including aluminum or other metals), reinforced masonry, reinforced concrete and wood.

1.2 EARTHQUAKE DESIGN PHILOSOPHY

The engineering intention behind earthquake resistant design is not to make earthquake-proof buildings that will not get damaged even during the rare but strong earthquake; such buildings will be too robust and also too expensive. Instead, the engineers make buildings to resist the effects of ground shaking, although they may get damaged severely but would not collapse during the strong earthquake. Thus, safety of human life and contents inside of the building are assured in earthquake resistant buildings. This is a major objective of seismic design codes throughout the world. The earthquake design philosophy may be summarized as follows;

- i. Under minor but frequent shaking, the main members of the building resist earthquake impact without being damaged (staying at elastic range); however building parts that do not carry load may sustain repairable damage.
- ii. Under moderate but occasional shaking, the main members may sustain some repairable damage, while the other parts of the building may be damaged even may need replacement.
- iii. Under strong but rare shaking, the main members may sustain severe (even irreparable) damage, but the building should not collapse.

1.3 SEISMIC RETROFITTING TECHNIQUES

- Earthquake creates great devastation in terms of life, money and failures of structures.
- Upgrading of certain building systems (existing structures) to make them more resistant to seismic activity (earthquake resistance) is really of more importance.
- Structures can be (a) Earthquake damaged, (b) Earthquake vulnerable
- Retro fitting proves to be a better economic consideration and immediate shelter to problems rather than replacement of building.

1.4 SEISMIC RETROFITTING OF CONCRETE STRUCTURES:

Definition:

It is the modification of existing structures to make them more resistant to seismic activity, ground motion, or soil failure due to earthquakes.

The retrofit techniques are also applicable for other natural hazards such as tropical cyclones, tornadoes, and severe winds from thunderstorms.

1.5 NEED FOR SEISMIC RETROFITTING:

- To ensure the safety and security of a building, employees, structure functionality, machinery and inventory
- Essential to reduce hazard and losses from non-structural elements.
- Predominantly concerned with structural improvement to reduce seismic hazard.
- Important buildings must be strengthened whose services are assumed to be essential just after an earthquake like hospitals.

1.6 PROBLEMS FACED BY STRUCTURAL ENGINEERS ARE:

Lack of standards for retrofitting methods – Effectiveness of each methods varies a lot depending upon parameters like type of structures, material condition, amount of damage etc.,

1.7 BASIC CONCEPT OF RETROFITTING

- Up gradation of lateral strength of structure
- Increase in ductility of structure
- Increase in strength and ductility

1.7.1 Classification of Retrofitting Techniques

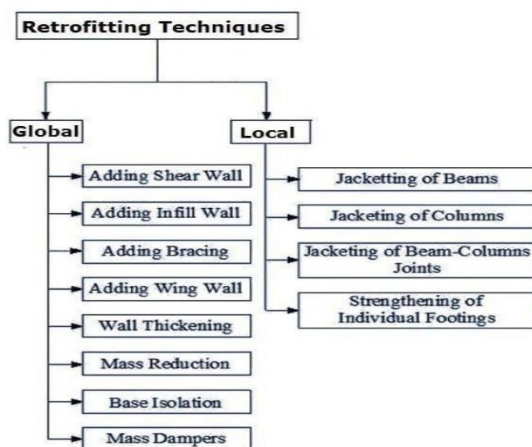

Fig 1.1 Retrofitting Techniques

1.7.2. Adding New Shear Walls:

- Frequently used for retrofitting of non-ductile reinforced concrete frame buildings.
- The added elements can be either cast in place or precast concrete elements.
- New elements preferably be placed at the exterior of the building.
- Not preferred in the interior of the structure to avoid interior moldings.



Fig 1.2. Additional Shear Wall

1.7.3 Adding Steel Bracings

- An effective solution when large openings are required.
- Potential advantages due to higher strength and stiffness, opening for natural light can be provided, amount of work is less since foundation cost may be minimized and adds much less weight to the existing structure.

1.7.4 Adding Steel Bracings:

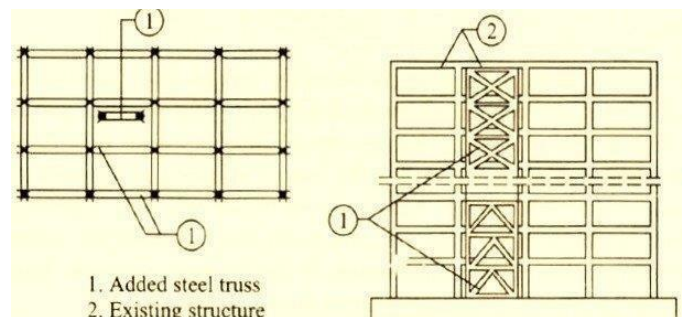

Fig 1.3. RC Building retrofitted by steel bracing

1.7.5 Jacketing (Local Retro fitting Technique):

This is the most popular method for strengthening of building columns.

Types of Jacketing:

- Steel jacket
- Reinforced Concrete jacket
- Fiber Reinforced Polymer Composite (FRPC)jacket

Purpose for jacketing:

- To increase concrete confinement
- To increase shear strength
- To increase flexural strength

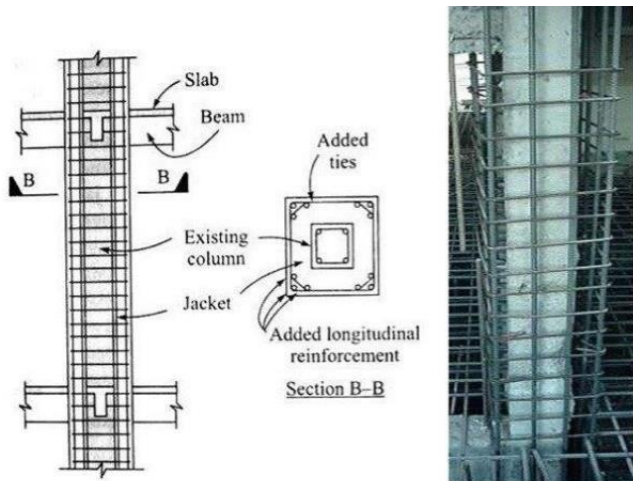

Fig 1.4. Column Jacketing

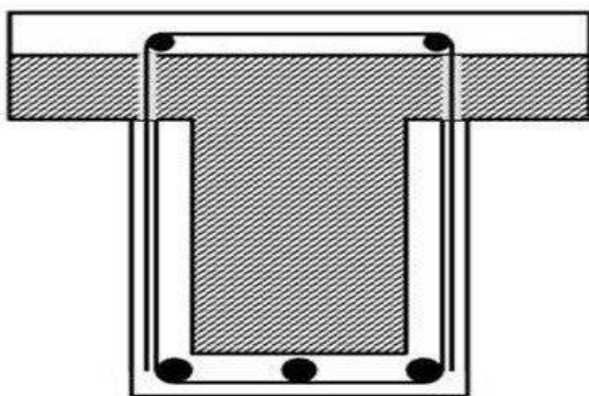

Fig 1.5. Beam Jacketing

1.7.6 Base Isolation

Isolation of superstructure from the foundation is known as base isolation. It is the most powerful tool for passive structural vibration control technique most powerful tool for passive structural vibration control technique.

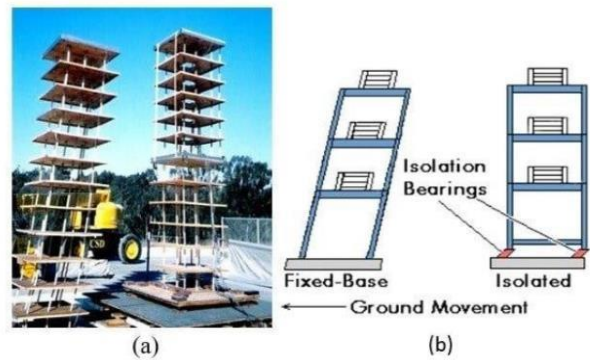

Fig 1.6. Base Isolation

Advantages of base isolation

- Isolates Building from ground motion–Lesser seismic loads, hence lesser damage to the structure,-Minimal repair of superstructure.
- Building can remain serviceable throughout construction.
- Does not involve major intrusion upon existing upper structure

Disadvantages of base isolation

- Expensive
- Cannot be applied partially to structures unlike other retrofitting
- Challenging to implement in an efficient manner

1.7.7 Mass Reduction technique

This may be achieved, for instance, by removal of one or more storey’s as shown in Figure. In this case it is evident that the removal of the mass will lead to a decrease in the period, which will lead to an increase in the required strength.

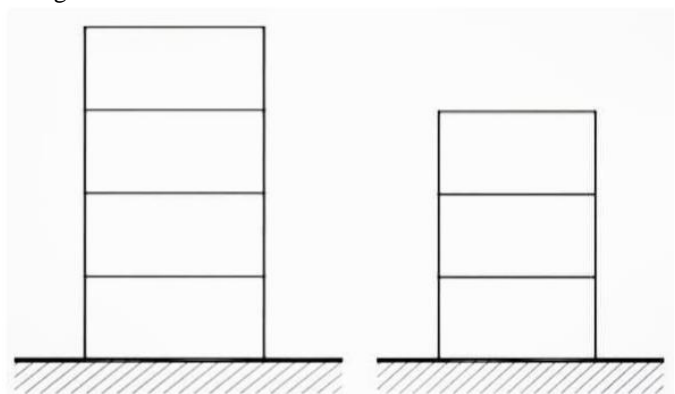

Fig 1.7. Seismic Retrofitting by Mass reduction (removal of Storey)

1.7.8 Wall Thickening Technique of Retrofitting:

The existing walls of a building are added certain thickness by adding bricks, concrete and steel aligned at certain places as reinforcement, such that the weight of wall increases and it can bear more vertical and horizontal loads, and also its designed under special conditions that the transverse loads does not cause sudden failure of the wall.

1.8 DESIGN OF SHEARWALL

Shear walls construction is an economical method of bracing buildings to limit damage. For good performance of well-designed shear walls, the shear wall structures should be designed for greater strength against lateral loads than ductile reinforced concrete frames with similar characteristics; shear walls are inherently less ductile and perhaps the dominant mode of failure is shear. With low design stress limits in shear walls, deflection due to shear walls is small. However, exceptions to the excellent performances of shear walls occur when the height-to length ratio becomes great enough to make overturning a problem and when there are excessive openings in shear walls. Also, if the soil beneath its footing is relatively soft ,the entire shear wall may rotate ,causing localized damage around the wall.

Shear wall Is designed as per IS 13920: 2016 Clause 10-page no. 14, IS 456: 2000.

1.9 GENERAL REQUIREMENTS

The thickness of the shear wall should not be less than 150mm to avoid unusually thin sections.

Very thin sections are susceptible to lateral instability in zones wherein elastic cyclic loading may have to be sustained.

The effective flange width for the flanged wall section from the face of web should be taken as least of

- The minimum reinforcement in the longitudinal and transverse directions in the plan of the wall should be taken as 0.0025 times the gross area in each direction and distributed uniformly across the cross-section of wall. This helps in controlling the width of inclined cracks that are caused due to shear.
- If the factored shear stress in the wall exceeds $0.25\sqrt{f_{ck}}$ or if the wall thickness exceeds 200 mm, there in forcement should be provided in two curtains, each having bars running in both the longitudinal and transverse directions in the plane of the wall. The use of reinforcement in two curtains reduces fragmentation and premature deterioration of the concrete under cyclic loading.

- The maximum spacing of reinforcement in either direction should be lesser than $l_w/5$, $3t_w$, and 450mm, where l_w is the horizontal length and t_w the thickness of the wall web.

1.10 PROBLEM STATEMENT

The main reason for this particular study is increasing proficiency and knowledge in earthquake resistant design plus seismic rehabilitation of existing buildings and also in order to increase familiarity with modeling & analyzing buildings against seismic loads by utilizing computer software

1.11 SCOPE OF PROJECT

To ensure the safety and security of a building, employees, structure functionality, machinery and inventory. Essential to reduce hazard and losses from structural elements. Predominantly concerned with structural improvement to reduce seismic hazard. Important buildings must be strengthened whose services are assumed to be essential just after an earthquake like hospitals.

1.12 OBJECTIVE

The objectives of this particular analysis are:

- i. To explore the consequences of earthquake forces on structures and literature search on earthquake resistant design
- ii. To assess the feasibility of seismic evaluation of advantages and buildings of using the retrofit measures designed for strengthening
- iii. To evaluate performance based design and compare various seismic analysis method
- iv. To model a real structure with a structural analysis software program and check out the earthquake results with various analysis methods given in standards and codes & propose most appropriate rehabilitation techniques in terminology of the overall performance

II. LITERATURE REVIEW

Chandurkar, Pajgade et.al (2013)(1) evaluated the result of a 10 storey developing with seismic shear wall structure using ETAB v 9.5. Main focus was comparing the modification of response by modifying the location of shear wall structure in the multi storey structure. 4 models were studied- one to be a bare frame structural program as well as rest three were of dual style structural system. The results were good for shear wall in span that is short at corners. Larger dimension of shear

wall was discovered to be inadequate in 10 or even under ten stories. Shear wall is an economical and effective choice for high rise structures. It was noticed that changing roles of shear wall was discovered to attract forces, thus correct positioning of shear wall structure is essential. Major quantity of horizontal forces has been taken by shear wall structure whenever the dimension is big. It was also found that shear walls at substantial locations decreased displacements as a result of earthquake.

Viswanath K.G et.al (2010)(7) investigated the seismic performance of reinforced concrete structures utilizing concentric steel bracing. Evaluation of a 4, 8, 12 as well as 16 storied building in seismic zone IV was completed using Staad Pro software, as per Is actually 1893: 2002 (Part I). The bracing was supplied for peripheral columns, as well as the usefulness of steel bracing distribution across the level of the structure, on the seismic functionality of the structure was studied. It was discovered that lateral displacements of the structures decreased after working with X type bracings. Steel bracings have been discovered to lessen flexure as well as shear demand on the beams as well as columns & transport lateral load by axial load mechanism. Building frames with X-category bracing have been discovered to have minimum bending as than various other kinds of bracing. Steel bracing technique was discovered to be a much better option for seismic retrofitting because they don't increase the entire mass of the structure considerably.

Chavan, Jadhav et.al (2014)(2) studied seismic evaluation of reinforced concrete with various bracing plans by equivalent fixed technique through the Staad Pro. software. The plans considered were diagonal, V type, inverted X-type and V-type. It was noticed that lateral displacement reduced by fifty % to sixty % and maximum displacement reduced by utilizing X type bracing. Base shear of the structure was also found to boost from the bare frame, by using of X type bracing, indicating increased stiffness.

Esmaili et al. (2008) (3) analyzed the structural element of a fifty six stories high tower, located in an impressive seismic zone in Tehran. Seismic evaluation of the structure was done by nonlinear dynamic analysis. The current building had primary wall space and the side walls of its as shear walls, attached to the primary wall structure by coupling of beams. The conclusion was considering the time dependency of concrete. Steel bracing product must be supplied for energy absorption for ductility, but axial load is able to have undesirable impact on the performance of theirs. It's both economically and conceptually unacceptable to make use of shear wall structure as each gravity and bracing technique.

Confinement of concrete in shear wall space is option that is good for offering stability and ductility..

Akbari et al. (2015)(4) assessed seismic vulnerability of steel X braced as well as chevron braced Reinforced Concrete by developing analytical fragility curve. Study of different parameters as level of the frame, the p delta impact as well as the portion of bottom shear just for the bracing technique was completed. For a certain created base shear, steel braced RC dual methods have very low injury probability as well as bigger capacity than unbraced phone system. Combination of more potent bracing and weaker frame cuts down on the damage probability on the whole system.

Irrespective of height of the frame, Chevron braces are definitely more powerful than X type bracing. Just in case of X type bracing technique, it's far better to distribute foundation shear consistently between the brackets and also the RC frame, whereas in case of Chevron braced method it's acceptable to allot larger worth of share of base shear on the brackets. Including p delta effect increases harm probability by twenty % for shorter dual program and also by 100% .

Kappos, Manafpour et.al (2000)(5) presented brand new methodology for seismic design of RC developing based upon achievable partial inelastic type of the framework as well as performance requirements for 2 unique limit states. The procedure is developed to a format which may be incorporated with design codes as Eurocode eight. Time-History (Nonlinear dynamic) analysis as well as Pushover analysis (Nonlinear Static analysis) has been investigated. The adopted technique confirmed better seismic performance than regular code procedure; at minimum in case of typical RC frame building. It was discovered that behavior under "life safety" was simpler to manage than under serviceability earthquake due to the adoption of performance requirements affecting ductility needs of users for "life safety" earthquake.

Yamada et al.(2015) (6) studied, experimentally and also analytically, deformation & fracture qualities of lateral load resisting systems shear wall structure for RC frame and steel bracing for metal multi storey frame below earthquake, since versions having three various spans along with three, six as well as nine storeys. Deformations as well as facture outcomes for all of the 3 cases are compared and differences are clarified by normalization of suggested horizontal resisting proportions.

S.S. Patil et al.2013 (7) presented seismic evaluation of excessive rise building by using various lateral load resisting system which are one) bare frame, 2)brace frame, three) shear wall structure frame. This analysis is completed with Response Spectrum Method, and utilizing STAAD Pro

application. Test outcome is based on parameters as base shear, story deflection and story drift. They realized that shear wall design provides a lesser amount of story deflection as well as story drift compared to bare frame and braced frame.

Hassaballa A.E. et al.(2013)(8) eight studied the seismic evaluation of a RC developing, and investigate the functionality of existing construction in case subjected to seismic loads. This particular building frame was examined by Response Spectrum Method as well as frame is computed via STAAD Pro application. For seismic evaluation of multistory structure they used static load as well as seismic load and get outcome which design based on reaction spectrum technique necessary large dimension of to resist huge displacement. And realized that drift resulting from nodal displacement as a result of mix of seismic loads and static load had been approximately two to three times the allowable drifts.

Mindaye et al, (2016)(9) nine analyzed the seismic effect of noncommercial G ten RC frame development is examined by the linear evaluation methods of equivalent fixed lateral forces as well as Response spectrum technique using ETAB primary 2015 software as per Is actually 1893:2002 part1. Various result like lateral force, displacement, story drift, overturning moment, base shear are plotted to evaluate the outcome of the dynamic and static analysis. They concluded that powerful story shear is under story shear for those instances. Equivalent static lateral force technique provides higher worth of force as well as moments that make creating uneconomical hence consideration of reaction spectrum strategy is necessary.

Padol S. et al(2015)(10) studied the seismic evaluation of multistoried RCC construction with mass irregularity at various floor amount are performed. This paper highlights the impact of mass irregularity on various floors in RCC construction with Time History Method as well as analysis is accomplished by ETABS software. They realized that anytime system has various irregularity the impact of earthquake on structure could be reduce through shear wall, base isolation etc.

Patil A. S, et.al (2013) (11) studied nonlinear powerful evaluation of ten storied RCC developing considering various seismic intensities as well as analyzed seismic result of that structure. The structure under consideration is modeled with the aid of Sap 2000 15 software and five distinct time histories are used. The outcome of the research shows comparable variations design in seismic effect like base shear as well as storey displacements and realized that time past is practical technique employed for seismic analysis. It offers a much better check on the safety of system analyzed as well as created.

Bhagwat et al.(2014)(12) studied powerful evaluation of G twelve multistoried practiced RCC developing considering for Bhuj and Koyna earthquake is taken out. The time History Analysis and Response Spectrum Analysis along with seismic reactions of the structure are comparatively studied. The modeled with the aid of ETABS9.7.2 application. 2 time histories (i.e. Koyna and Bhuj) are already utilized to cultivate various criteria (base shear, storey displacement, storey shear), and also realized that, the valuation of base shear for Bhuj earthquake is 49.11 % much more than the Koyna earthquake, and Response Spectrum technique provides fifty % more outcome compared to Time History Analysis.

Dubey et al. (2015) (13) presented design of multistoried irregular construction with twenty accounts and modeled it with software STAAD PRO for seismic zone IV in India, powerful effect of creating under real earthquake, DELINA (ALASKA)2000 are deemed. This particular paper highlights the comparison of Time History Method and Response Spectrum Method. The story displacement effect continues to be acquired with each technique of powerful analysis, and also Concluded that Time History Analysis is discovered to be two to eight % above that of Response Spectrum Analysis in all kind of building i.e. irregular and regular, For excessive rise building it's essential to offer powerful evaluation due to nonlinear distribution of force. Storey displacement is found increased in THM as compared to RSM, and found the starting shear is increased in RSM as opposed THM. Thus it could be realized that time history examination is economically better for designing.

Rampure et al. (2016) (14) studied the powerful time history analysis as well as reaction spectrum evaluation associated with a concrete gravity dam by utilizing STAAD PRO. Finite component strategy is utilized to evaluate the dam along with a concrete gravity dam design is ready in STAAD PRO to do time history analysis and response spectrum evaluation as well as comparison is completed between both these techniques. They concluded that STAAD-PRO is very practical & less challenging for powerful analyses and it offers a computing setting to investigate modeling assumption as well as computational tasks associated with the fixed as well as seismic structural balance of gravity dam. It's essential to evaluate the framework by powerful evaluation of both these technique for below the level of dam 100m and above the height of dam 100m.

Hawaladar et al. (2015) (15) presented G+12 storey developing type with as well as without infill the time history analysis utilized for Koyna earthquake and Bhuj feature it's carried through in ETABS 2013 application. The seismic responses of story displacements, storey drifts are found. Time history plots

of base force v/s time as well as roof displacement v/s period for each time history capabilities are compared and also analyzed. They realized the displacement values for bhuj functionality are bigger compared to the displacement value for Konya performance and also those for infill building are under that with no in filled building as well as drift importance of bhuj functionality had been far more in comparison with drifts for Konya function as well as infill drift values are comparatively much less than for without infill drift values for equally time history feature.

Bahador et al. (2012)(16) studied Multi storey unusual buildings with twenty accounts are modeled utilizing software packages ETABS and also Sap 2000 v.15 for seismic zone V in India. As well as works with the impact of the variation of the construction level on the structural result of the shear wall structure developing. Powerful responses of construction under real earthquakes, EL CENTRO 1949 and CHICHI Taiwan 1999 are examined. This particular paper highlights the reliability as well as exactness of your time History analysis in comparison with probably the most widely followed Response Spectrum Analysis and Equivalent Static Analysis. And realized that time history examination is a stylish tool to imagine the performance amount of building under a certain earthquake as well as fixed examination isn't enough for higher rise building, the outcome of equivalent fixed analysis are around uneconomical since values of displacement are much higher compared to powerful analysis.

Harshita et al. (2014)(17) studied the powerful behavior of multistoried symmetrical building frame utilizing IS1893 2002 code advised result spectrum technique as well as time history technique. The moment history analysis, 2 earthquake information like from earlier earthquakes corresponding to Bhuj (2001 Spitak and) (1988). Analysis concentrates to assess the base shear, response spectra at various story levels, bending moment diagram, shear force diagram variation in the structure. Analysis has been performed using the STAAD-PRO application depending on the matrix analysis. According to the end result it's discovered that the base shear from time history examination is somewhat higher than reaction spectrum analysis, this might be because of variation of amplitude as well as frequency information of the soil motion.

Amit A Sathawane and R. S. Deotale et.al (2012), (18) In this analytical work, the researcher obtained the best affordable slab among flat slab with no drop, flat slab inclusive drop as well as grid slab on the foundation of hand-operated analysis in addition to software analysis. They used direct design technique as well as equivalent frame method to evaluate the flat slab. The approximate procedure as well as plate theory technique was utilized to evaluate grid slab,

because hand-operated analysis progression as well as software analysis were getting finished by utilizing STAAD Pro. In the power grid slab process, the volume of concrete needed is much more as compared to dull slab. Steel amount appears to be more needed in the flat slab limited of drop panel as in comparison to flat slab additional inclusive of drop as well as grid slab. As per economy, the flat slab incorporated with fall board is better as than Flat slab and grid slab extraordinary of drop.

Anuja Walvekar, H.S Jadhav et.al (2015), (19) In this particular research, the scientists described the functionality of creating in seismic loading quality inclusive as well as exclusive of shear wall structure, utilizing R. S. M in ETABS applications to evaluate the structure. They needed 5 various cases to evaluate the 15th storey building that is, functionality of dull slab building included with shear wall structure, performance of flat slab with no shear wall, creating with L design shear wall, dull slab with shear wall along it periphery as well as dull slab with non-parallel shear wall along periphery. Following the evaluation of result, looking at the seismic result is 3.08 % which is much more in premium of shear wall situation. The framework inclusive shear wall has least displacement along periphery that is 29.13% and 10.06 %. It had also been examined that in L type shear wall structure as well as structure with non-parallel shear wall the duration of periphery had significantly less displacement. In all of the cases, storey drift are discovered to be in allowable limit. Building with shear wall structure is preeminent for seismic along with wind loading problem.

Dr. Uttamasha Gupta, Shruti Ratnaparkhe, et.al (2012), (20) Following effect comparison the storey drift values are significant at mid-level of the framework. For dull slab added with fall has much more drift values for span that is short and therefore are smaller in longer span. Right now there aren't any consequences on storey drifts with or perhaps with no shear wall structure included in building. For smaller span, master slave alternative might be utilized however for longer span practical technique followed.

Kaulkhere R.V, Prof. G.N Shete, et.al (2017)(21) The design and analysis of dull slab for various condition like square and rectangular with as well as with no drop, pushover analysis (statics analysis) as well as earthquake analysis (seismic co efficient method) by using ETABS application. Following the analysis of the end result, the optimum strip moment was practically identical for square and rectangular slab and also the importance of base shear was much higher in square smooth slab with no drop, The storey displacement appears to be much higher in rectangular slab as well as the storey drift

importance for square and rectangular was identical, all-natural period great was almost same for both shapes.

Miguel Fernandez, Aurelio Muttoni and Jakab Kunz, et.al (2010), (22) In this particular study, for strengthening of slab not in favor of punching shear, the usage of after set up shear reinforcement following the completion of construction work. It's likewise recognized as post shear reinforcement, used to enhancement of pounding shear power of flat slab. Critical shear crack principle has utilized to develop the post installed shear reinforcement. The primary conclusion of this particular work was the inclined shear reinforcement was more efficient to enhance punching shear strength

In this proposed perform, comparison between flat post and slab tensioned dull slab for seismic Zone two, three with taking numerous kinds of multistoried creating as G nine, G eleven, G fourteen. The various model cases have diverse geometry along with various material properties. To evaluate the various model cases utilizing liner time history analysis process in Staad Pro, several conclusions drawn Post tensioned flat slab was more efficient under seismic loading

Moh. Imran, M.Visweswara, Dr. Jammi Ashok et.al (2017), In this particular work, to analyze and model of G three standard frame building inclusive of shear wall structure as well as G three flat slab inclusive of shear wall structure in Seismic Zone three completed with SAP-2000. The plan area is (twenty four x twenty four) m, level of plinth 1.8m plus floor level is 3.6m. Following the end result comparison frequent frame development has improved performance as compare to plate slab. In order to improve the functionality of flat slab developing, shear wall could be provided

Mk Devtale , S.S Sayyed , Y.U Kulkurni, P.G Chandak, et.al (2016),“(25)In this particular approach, to improve the punching shear strength by using shear band reinforcement that was divided in five groups. For starters, check out the result of adding the shear band is hanged upon leading grid; tie the bottom and top grid simultaneously. second group check out the outcome of installing the shear band with perpendicular strut, with bended strut at 450, 3rd team investigate the consequence of concentrating shear reinforcement putting in the shear band within the column, 4th group investigate the result of radial sharing of shear band system around 5th group and the column investigate the effect of box style shear band in the area of the column. Following the comparison of outcome, the shear band appears to not be good at common punching shear. The shear band improves the crucial punching shear capacity, absorption and ductility. In case shear band utilized like a mat, subsequently the load carrying capability spikes of up to fifty five %, energy

absorption 148 %, ductility seventy nine %, and stiffness 38.5 %. In case shear band offered in both instructions and then load carrying capacity will boost at six %, energy absorption twenty two %, ductility twenty two %, stiffness 5.2 %. This particular effort was recommended by the respective authors.

Nasr. Z. Hussan, Mostafa A. Osman et.al (2017), (25)In this proposed work, the discovery in the earthquake evaluation of multistoried flat slab developing rested on plain and also sloping ground are done by the scientists. For sloping ground and plain ground, linear analysis technique is utilized in ETABS software. You will find 4 instances which had been viewed in ten storey developing resting on the rest and plain ground of 3 cases on oblique ground at perspective of 100,200,300 were also mentioned. Following the analysis as well as comparison of result Storey drift in flat slab is much more in basic ground as in comparison to inclining ground.

P. Srinivasulu and A. Dattatreya Kumar et.al (2015), (27)In this particular work, the finding of genuine functionality of R.C.C. dull slab developing under earthquake loading continues to be done. It was discovered that because of seismic loading, the result on the flat slab in terminology of storey displacement, frequency, base shear, storey stage acceleration and definitely the result of pounding shear in all kinds of dull slab i.e. dull slab not such as drop, dull slab with fall, flat slab with just shear wall structure, flat slab with drop as well as shear wall structure have additionally concluded. The R.S.M is needed with the aid of ETABS application. Following the end result was compared, essential mode of frequency is twenty % increase in flat slab with drop and also in order to improve stiffness property with shear wall structure the worth was enhanced with ninety six %. The importance of essential frequency was significant at bottom floor and also much less at the best floor as well as the importance of essential time period increased at best floor to bottom floor. The storey shear great appears to be comparatively large at bottom floor and much less at top floor. Thus concluding this particular, the flat slab inclusive of drop as well as shear wall structure is better choice to conquer the displacement in X direction, too base shear enhanced when industry increases. In case drop has supplied in interior panel and then punching shear gets lowered by twenty five % ..

R. S More and V. S. Sawant et.al (2015), (28)The job done in this approach type, the evaluation of flat slab of earthquake loading state has drawn out. In this particular analysis, flat slab was created with the aid of D.D.M, Finite element method ande.f.m (for abnormal geometry as well as abnormal layout). Different the end result, it's been discovered that in Is actually Code 456 2000, there are not a provisions regarding flat slab for seismic loading, it's merely depending on the gravity loading problems. In case the developing hasn't done

correctly, then cracks are developed near the assistance which concluding the drastic success when any framework considered during construction.

Bhagavathula Lohitha as well as S.V. Narsi Reddy et.al (2014)(29) Investigate a current RC framed building (G three) with soft storey was analysed for 2 diverse cases (a) considering both infill mass as well as infill stiffness and also (b) contemplating infill mass but without considering infill stiffness utilizing software SAP2000. 2 distinct support situations were considered checking the outcome of support problems in the multiplication elements. Non-Linear and linear analyses were carried out for the models. Realized that support problem influences the result substantially and may be essential parameter to choose the force amplification component.

Anchal V. Sharma as well as Laxmikant C. Tibude et.al (2016) (30) learned a RC framed building (G three) with wide open ground storey was analysed for linear elastic evaluation with the by hand or maybe commercial software program it's realized the displacements for the wide open ground storey is smaller than the completely unfilled wall framed and blank framed building for all of the seismic zones.

D. J. Chaudhari, Prajakta T. Raipure et.al (2015)(31) analyses RC framed building (G ten) with OGS for all the influences of multiplication aspect of other international codes and Indian Standard codes of the seismic study and loads fragility curves that is produced by STAAD PRO. And after the evaluation they mentioned the OGS frames in terminology of terrain storey drifts is growing in increasing order of MF's by most codes for all of the overall performance level. As per Is code the very first storey is much more weak next ground storey however for Israel code it's false. Additionally they mentioned that as per Israel code, MF just in ground storey might not supply the likely outcomes in any other stories. In case MF put on also for any adjacent storey might enhance the functionality of OGS buildings.

Aditya Deshmukh et.al (2015) (32) studied a RC framed building (G ten) construction with open ground storey just for the various seismic zones with the different situations of creating element: (a) unfilled frame developing (b) building with uniform infill in most storey (c) building with OGS (d) OGS with stiffer column(e) OGS with corner shear wall structure (f) OGS with corner cross bracing (g) OGS with composite columns. And also the designs had been produced from the business software program ETABS. From the lateral displacement graphs he found out that lateral displacement is much higher in OGS style as compared to various other structure. Additionally he mentioned with corner shear wall

displacement minimization is bigger therefore it's ideal type of OGS building with corner shear wall. Also, he realized that by studied that OGS building with corner shear wall structure and also cross bracing are discovered to be really successful in decreasing stiffness irregularity plus bending OGS and moment with stiffer column plus composite columns are extremely successful decreasing drift and stiffness irregularity but there's increasing bending moment and shear force in original storey. And ductility is found much more in the infill frame board compared to the open ground storey developing version.

Prof. Dipak Jivani, Dr. R.G. Dhamsaniya, Prof. M.V. Sanghani et.al (2017)(33) examined the dynamic evaluation provides higher time period as in comparison to fixed analysis. Higher time period noticed in bare frames as well as the time period improves as the opening area portion of construction increases that is the happened due to decrease in stiffness. It's been discovered that optimum base shear as well as roof displacement capability both the items is bigger for the with no infill situation than the with infill situation. And developing modeled with infill stiffness has much more ductility than building modeled with infill stiffness. Also, he realized that following pushover analysis foundation shear multiplication element found out is smaller than the Is actually code recommended.

Amol karemore, Shrinivas Rayadu et.al (2015) (34) studied a (G+3) building with OGS for the seismic zone 3 and they have done pushover analysis to evaluate effect of seismic behaviour of building. They found that OGS building are more sensitive to earthquake than full infill building duo to soft storey effect. Infill walls increases stiffness while decreases lateral displacement. They noticed that there is no effect of zone on multiplication factor. As per IS 1893stated that magnification factor of 2.5 to be applied on calculated shear force and bending moment is very much. After linear and non-linear analysis they concluded that the magnification factor (MF) for bending moment is in the range of 1.06-1.98 for columns and for beam is in range of 0.92-1.06 of ground storey. Magnification factor (MF) for shear force is in range of 1.42-1.52 for column and for beam is in range of 0.97-1.07 of ground storey.

Akshay S. Paidalwar¹ and G.D. Awcha et.al (2017)(35) stated that the stiffness of the structure is an important factor in case of OGS type building. RC framed building with open ground storey is known to be performing poorly during the strong earthquake shaking. In elastic analysis it has been observed that for OGS building the stiffness is almost same to Bare Frame building. 8. Ankita Pramod Shelke, Dr. Rajashekhar S. Talikoti(2015) concluded from the literature reviews that the RC framed building with open ground storey

perform poorly at the time of earthquake shaking. The lateral stiffness is less than 70 percent of that of the adjacent upper storey or less than 80 percent of the average stiffness of adjacent three storeys above it causing soft story effect to produce. For a OGS building without shear wall or bracing the strength is very weak and easily collapsed during earthquake. Also they stated that after analysis base shear can be more than twice to that expected by equivalent earthquake force method with or without infill or by response spectrum method when no infill in the analysis of model.

III. CONCLUSION

This project work was a small effort towards perceiving the how introducing bracing or a shear wall in a building can make in difference in protecting the building in earthquakes. Almost all the buildings in India are RC frame, and earthquake tremors are felt every now a then in some or the other part of the country. Hence through this project it was tried to appreciate the effectiveness and role of this small extra structural elements that can save both life and property, at least for most of the earthquakes.

The following conclusions were drawn at the end of the study

- Base Shear produced in the Bare Frame is maximum for Shear wall at C.
- In case of bracing system, Bracing System C (with braces at the corners) are the most effective one than other bracing systems, effectively reducing top-storey drift and inter storey drifts in both X- and Z- directions.
- There is hardly any reduction in drift along Z- direction due to Bracing B, for all the ground motions.
- Shear Wall A is effective in reducing drifts along X- direction only, and Shear Wall B is effective in reducing drifts along Z- direction only, for all the ground motions.
- Above all Shear Wall C is the best in all the stiffening cases considered.
- Shear wall elements are very much efficient in reducing lateral displacement of frame as drift and horizontal deflection induced in shear wall frame are much less than that induced in braced frame and plane frame
- The location of shear-wall and brace member has significant effect on the seismic response than the plane frame
- Shear wall construction will provide large stiffness to the building by reducing the damage to the structure.

- The concept of using steel bracing is one of the advantageous concepts which can be used to strengthen or retrofit the existing structures
- Steel bracings can be used as an alternative to the other strengthening or retrofitting techniques available as the total weight on the existing building will not change significantly
- Steel bracings reduce flexure and shear demands on beams and columns and transfer the lateral loads through axial load mechanism.

REFERENCES

- [1] Chandurkar P. P, Dr. Pajgade P. S. (2013). "Seismic Analysis of RCC Building with and Without Shear Wall." , International Journal of Modern Engineering Research (IJMER) (2249-6645).
- [2] Chavan Krishnaraj R. ,Jadhav H.S. (2014). "Seismic Response of RC Building With Different Arrangement of Steel Bracing System.", International Journal of engineering Research and Applications (2248-9622).
- [3] Esmaili O. et al. (2008). "Study of Structural RC Shear Wall System in a 56- Storey RC Tall Building.", The 14th World Conference on Earthquake Engineering October 12-17, 2008 , Beijing, China.
- [4] Akbari R. et al. (2014). "Seismic Fragility Assessment of Steel X-Braced and Chevron- Braced RC Frames.", Asian Journal of Civil Engineering (BHRC), VOL- 16 No.1 .
- [5] Kappos Andreas J., Manafpour Alireza (2000). "Seismic Design of R/C Buildings with the aid of advanced analytical techniques." Engineering Structures 23 (2001) 319-332.
- [6] Yamada M. et al. " Multistorey Bracing Systems of Reinforced Concrete and Steel – Rigid Frames Subjected To Horizontal Loads- Proposition of Total Evaluation on the Aseismic Capacity for Design."
- [7] Viswanath K.G. et al.(2010). "Seismic Analysis of Steel Braced Reinforced Concrete Frames." International Journal of Civil & Structural Engineering (0976-4399).
- [8] A.E Hassaball, "Seismic analysis of a RC building by RSM", IOSR journal of engineering, volume 3, Issue 9, ISSN:2250- 3021, September 2013.
- [9] Sagar R. Padol, "Review paper on seismic response of multistoried RCC building with mass irregularity" International journal of research in engineering and technology. ISSN: 2321-7308.
- [10] Girum mindaye, "Seismic analysis of multistory RC frame building in different seismic zone", International Journal of Innovative Research in Science, Engineering and Technology, vol.-05, issue-09, sep.2016.
- [11] Patil A.S, Kumbhar P.D, "Time history analysis of multistoried RRC building for different seismic

- intensities”, International Journal of Structural and Civil Engineering Research, vol.-02, issue-03, Aug 2013.
- [12] Bhagwat Mayuri D, “Comparative study of Performance of multistoried building for Koyna and Bhuj earthquake by THM and RSM”, International Journal of Advanced Technology in Engineering and Science, vol.no.-02, issue- 07, ISSN:2348-7550, July 2014.
- [13] Dubey S.K, Sangamnerka Prakash, Agrawal Ankit, “Dynamic analysis of structures subjected to earthquake load”, International Journal of Advance Engineering and Research Development, vol.-02, issue-09, ISSN:2348-4470, Sep.2015.
- [14] Rampure Aarti baburao, “Comparison between Response Spectrum Method and Time History Method of dynamic analysis of concrete gravity dam”, Open Journal of Civil Engineering, June 2016.
- [15] Hawaldar Jyothi C, “Earthquake analysis of G+12storey building with and without infill for Bhuj and Koyna earthquake function”, International Research Journal of Engineering and Technology(IRJET), vol.-2, issue-05,ISSN:2395-0056, august 2015.
- [16] Bahador Bagheri, “Comparative study of the static and dynamic analysis of multistorey irregular building”, International Journal Civil, Environmental Structural Construction and Architectural Engineering, vol-6.
- [17] Harshita, “seismic Analysis of symmetric RC frame using RSM and THM”, International Journal of Scientific Research and Education, vol-02,issue03,march 2014.
- [18] Amit A Sathawane and R. S. Deotale (2012), “Analysis of Flat Slab and Grid Slab and Their Cost Comparison”, International Journal of Advanced Technology in Civil Engineering, ISSN: 2231-5721, Vol. 01, Issue 02, pp.122-126.
- [19] Anuja Walvekar, H.S Jadhav (2015), “Parametric Study of Flat Slab Building Without or With Shear Wall to Seismic Performance”, International Journal of Research In Engineering, ISSN: 2319-1163, Vol. 04, Issue 04, pp. 601-607.
- [20] Dr. Uttamasha Gupta, Shruti Ratnaparkhe, (2012), “Seismic Behavior of Building Having Flat Slab With Drop”, International Journal of Emerging Technology and Advanced Engineering, ISSN: 2250-2459, Vol. 02, Issue 10, pp. 416-421.
- [21] Kaulkhere R.V, Prof. G.N Shete, (2017), “Analysis and Design of Flat Slab with Various Shape”, International Journal of Scientific Research and Development, ISSN: 2455- 2631, Vol. 02, Issue 05, pp. 538-544.
- [22] Miguel Fernandez, Aurelio Muttoni and Jakab Kunz, (2010), “Strengthening of Flat Slab against Punching Shear using Post Installed Shear Reinforced”, ACI Structural Journal, Title No.107-S43, Vol.107, Issue 4, pp. 434-442.
- [23] Moh. Imran, M.Visweswara, Dr. Jammi Ashok (2017), “A Comparative Study of Flat Slab Vs Post Tensioned Flat Slab”, International Journal of Scientific Research and Development, ISSN: 2321-0613, Vol. 05, Issue 09, pp. 979-982.
- [24] Mk Devtale , S.S Sayyed , Y.U Kulkurni, P.G Chandak, (2016), “Comparison of Seismic Response Between Flat Slab vs. Regular Frame Building” International Journal of Advancement In Engineering Technology, Management and Applied Science, ISSN: 2349- 3224, Vol. 03, Issue 06, pp. 104-111.
- [25] Nasr. Z. Hussan, Mostafa A. Osman (2017), “Enhancement of Punching Shear Strength of Flat Slab Using Shear Bond Reinforcement” Housing and Building National Research Center, pp. 1-7.
- [26] P. Manjunath, Yogendra R. Holebsgilu (2016), “Seismic Analysis of Multi Storied Building With Flat Slab Resting On Plain and Sloping Ground”, Bonfring International Journal of Machine Interface, ISSN: 2277-5064, Vol. 4, Special Issue, pp.20- 25.
- [27] P. Srinivasulu and A. Dattatreya Kumar (2015), “Behavior Of R.C.C Flat Slab Under Earthquake Loading”, International Journal Of Science And Research, ISSN: 2277-2685, Vol. 05, Issue 07, pp. 821- 829.
- [28] R. S More and V. S. Sawant (2015), “Analysis of Flat Slab”, international journal of science and research, ISSN: 2319- 7064, Vol. 04, Issue 07, pp. 98-101.
- [29] Bhagavathula Lohitha and S.V. Narsi Reddy (2014), “Earthquake Resistant Design of Low-Rise Open Ground Storey Framed Building”, International Open Access Journal of Modern Engineering Research (IJMER), Vol. 4, Issue 6, June 2014
- [30] Anchal V. Sharma, Laxmikant C.Tibude (2016). “ Effect of Position of Infill Wall for Seismic Analysis of Low Rise Open Ground Storey Building”, International Journal of Emerging Trends in Science and Technology
- [31] D. J. Chaudhari, Prajakta T. Raipure (2015), “Seismic Performance of Open Ground Storey RC Buildings for Major International Codes”, Journal of Civil Engineering and Environmental Technology, Volume 2, Number 10; April-June, 2015 pp. 42-48
- [32] Aditya Deshmukh (2015),” Earthquake Resistant Design Of Low-Rise Open Ground Storey Framed Building”, International Journal of Modern Trends In Engineering And Research (IJMTER), Volume 02, Issue 04, April – 2015.
- [33] Prof. Dipak Jivani, Dr. R.G. Dhamsaniya, Prof. M.V. Sanghani (2017),” Effect Of Infill Wall On Seismic Performance of RC Building With Open Ground Storey”, International Journal Of Advance Engineering And Research Development Volume 4, Issue 1, January -2017.

- [34] Amol Karemore, Shrinivas Rayadu (2015), “ Study on Effect of Zone on Magnification Factor for Open Ground Storey Buildings”, International Journal of Innovative and Emerging Research in Engineering, Volume 2, Issue 5, 2015.
- [35] Akshay S. Paidalwar¹ And G.D. Awcha (2017), “Seismic Analysis Of Open Ground Storey Building”, International Journal Of Civil Engineering Research, Volume 8, Number 2 (2017), PP. 69-79.
- [36] Ankita Pramod Shelke, Dr. Rajashekhar S. Talikoti(2015), “Survey Paper On Seismic Analysis Of Low-Rise Soft Storey Frame Building”, International Journal Of Emerging Technology And Advanced Engineering, Volume 5, Issue 6, June 2015 [30]. Giuseppe Oliveto and Massimo Marletta (2005) Seismic retrofitting of reinforced concrete buildings using traditional and innovative techniques, ISET Journal of Earthquake Technology, 42, 21-26.
- [37] Komal Bedi(2013) Study on Various Methods and Techniques of Retrofitting, International journal of Engineering Research & Technology, 2, 621-627.
- [38] Krishna G. Nair and Akshara S.P. (2017) Seismic analysis of Reinforced Concrete Buildings. International Research Journal of Engineering and Technology, 4, 165-169.
- [39] Kusuma B(2017) Seismic analysis of a high rise RC framed structure with irregularities. International Research Journal of Engineering and Technology, 4, 1338-1342.
- [40] M.A. Ismaeil and A.E. Hassaballa(2017) Seismic retrofitting of RC building by adding steel plate shear wall, International research journal of Engineering and Technology, 7, 49-62.