

A Review on Electric Line Man Safety With Password Based Circuit Breaker And Intimation of HT Wire Sag Using GSM

Prof. Karuna Shirsat¹, Mr. Shubham Wakode², Mr. Sanket Sarode³,
Mr. Vaibhav Varade⁴, Abu Taleeb Gawali⁵, Prashant Shitole⁶

¹ Prof, Dept of Electrical Engineering

^{2,3,4,5,6} Dept of Electrical Engineering

^{1,2,3,4,5,6} Padm Dr. V B Kolte College of Engineering Malkapur, Maharashtra, India

Abstract- A circuit breaker is an automatically operated electrical switch designed to protect an electrical circuit from damage caused by overload or short circuit. Its basic function is to detect a fault condition and interrupt current flow. Unlike a fuse, which operates once and then must be replaced, a circuit breaker can be reset (either manually or automatically) to resume normal operation. When operated manually we see fatal electrical accidents to the line man are increasing during the electric line repair due to the lack of communication and coordination between the maintenance staff and the electric substation staff.

In order to avoid such accidents, the breaker can be so designed such that only authorized person can operate it with a password. This ensures security of the worker because no one can turn on the line without his permission. The system is fully controlled by the 8 bit microcontroller of 8051 family. The password is stored in an EEPROM, interfaced to the microcontroller and the password can be changed any time unlike a fixed one burnt permanently on to the microcontroller. A keypad is used to enter the password and a relay to open or close circuit breaker, which is indicated by a lamp. Any wrong attempt to open the breaker (by entering the wrong password) an alert will be actuated, indicated by another LED.

Keywords- OTP, GSM, Circuit breaker; Password, Wireless communication.

I. INTRODUCTION

Nowadays, electrical accidents to the line man are increasing, while repairing the electrical lines due to the lack of communication between the electrical substation and maintenance staff. This project gives a solution to this problem to ensure line man safety. In this proposed system the control (ON/OFF) of the electrical lines lies with line man. This project is arranged in such a way that maintenance staff or line man has to enter the password to ON/OFF the electrical

line. Now if there is any fault in electrical line then line man will switch off the power supply to the line by entering password and comfortably repair the electrical line, and after coming to the substation line man switch on the supply to the particular line by entering the password.

Ultra sonic sensors are the devices that use electrical –Mechanical energy transformation to measure to distance from the sensor to the target object. These sensors are categorized into two types according to their working phenomenon piezoelectric sensors and electro static sensors. Here we are using the piezoelectric principle. PIR sensors are small, inexpensive, low power, easy to use and don't wear out. These sensors allow to sense motion, almost always used to detect whether a human has moved in or out of the sensors range.

II. LITERATURE SURVEY

Electric lineman protection using user changeable password based circuit breaker: A circuit breaker is an automatically operated electrical switch designed to protect an electrical circuit from damage caused by overload or short circuit. Its basic function is to detect a fault condition and interrupt current flow. Unlike a fuse, which operates once and then must be replaced, a circuit breaker can be reset (either manually or automatically) to resume normal operation. When operated manually we see fatal electrical accidents to the line man are increasing during the electric line repair due to the lack of communication and coordination between the maintenance staff and the electric substation staff. In order to avoid such accidents, the breaker can be so designed such that only authorized person can operate it with a password. Here, there is also a provision of changing the password. The system is fully controlled by the 8 bit microcontroller of 8051 family. The password is stored in an EEPROM, interfaced to the microcontroller and the password can be changed any time unlike a fixed one burnt permanently on to the microcontroller. A keypad is used to enter the password and a

relay to open or close circuit breaker, which is indicated by a lamp. Any wrong attempt to open the breaker (by entering the wrong password) an alert will be actuated, indicated by another lamp.

Password based circuit breaker: A circuit breaker is an automatically operated electrical switch designed to protect an electrical circuit from damage caused by overload or short circuit. Its basic function is to detect a fault condition and interrupt current flow. Unlike a fuse, which operates once and then must be replaced, a circuit breaker can be reset (either manually or automatically) to resume normal operation. When operated manually we see fatal electrical accidents to the line man are increasing during the electric line repair due to the lack of communication and coordination between the maintenance staff and the electric substation staff. In order to avoid such accidents, the breaker can be so designed such that only authorized person can operate it with a password. Here, there is also a provision of changing the password. The system is fully controlled by the 8 bit microcontroller of 16f877A family. The password is stored in an EEPROM, interfaced to the microcontroller and the password can be changed any time unlike a fixed one burnt permanently on to the microcontroller. A keypad is used to enter the password and a relay to open or close circuit breaker, which is indicated by a lamp. Any wrong attempt to open the breaker (by entering the wrong password) an alert will be actuated, indicated by another lamp. Index terms: Resistors, Capacitors, Diodes, Transistors, Voltage regulator, Rectifier, Microcontroller, EEPROM, Relay, Relay Driver.

III. EXISTING SYSTEM AND PROPOSEDSYSTEM

Existing system

Circuit breakers play a vital role in maintaining system security. Since their malfunctioning could results in further component outages and may lead to the insecure operating conditions. During maintenance of distribution lines there is a chance of communication gap between the electric line and sub-station operator or staff. This communication gap may risk life of electric line man. The control to turn ON/OFF the line lies with the line man only. During maintenance the entire line is turned off this cause inconvenience to the consumers.

Disadvantages of existing system

1. During maintenance the entire line is turned off this cause inconvenience to the consumers.
2. Improper communication between maintenance staff and substation causes the electrical accidents.

Proposed System

At present if there is any maintenance work at the distribution the entire line will be turned off which cause inconvenience to the consumers. The proposed system uses a microcontroller of the 8051 family and a rectified power supply. When the proposed system is ON the GSM modem will send the message to the receiver. A matrix keypad is interfaced to the microcontroller to enter a password. The password entered is displayed in the LCD. The entered password is compared with password stored in the ROM of the microcontroller. If the password entered is correct, then only the line can be turned ON/OFF. A relay is controlled by a relay driver IC, which is interfaced to the microcontroller also it is interfaced with the GSM modem .Whenever there is a maintenance work in the main line ,the line can be disconnected only when the password entered will match with the stored password. The relay ON/OFF operation will be indicated by the LED's; also it sends a message to the receiver about the line disconnection. As soon as the maintenance work is finished then line man should enter the same password as used to disconnect the line earlier.

Advantages of proposed system

1. Save the life of line man.
2. User friendly operation of main line.
3. Easy to install and operate.
4. Cost effective.
5. Easy to maintain and repair.

IV. IMPLEMENTATION

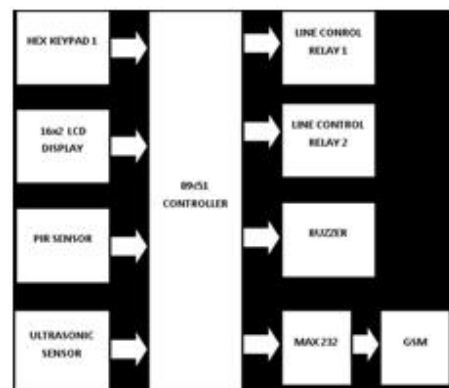

The circuit uses standard power supply comprising of a step down transformer from 12V and 4 diodes forming a bridge rectifier that delivers pulsating dc which is then filtered by an electrolytic capacitor of about 470µF. 5V power supply circuit is to be used to provide regulated 5V DC to the controller.

The PIR sensor will continuously produce IR radiations, when a warm body like a human or animal passes by sensor area. It senses the motion of human/animal and sends signal through a buzzer. Then buzzers make a sound and prevent people from entering the danger zone.

Working of the circuit components is as follows:

PIR Sensor: The PIR (Passive Infra-Red) Sensor is a pyro electric device that detects motion by measuring changes in the infrared (heat) levels emitted by surrounding objects. This motion can be detected by checking for a sudden change in the surrounding IR patterns. When motion is detected the PIR sensor outputs a high signal on its output pin. This logic signal can be read by a microcontroller or used to drive a transistor to switch a higher current load. Detection range up to 20 feet away.

Ultrasonic sensor: Ultrasonic sensors (also known as transceivers when they both send and receive, but more generally called transducers) work on a principle similar to radar or sonar, which evaluate attributes of a target by interpreting the echoes from radio or sound waves respectively. Active ultrasonic sensors generate high frequency sound waves and evaluate the echo which is received back by the sensor, measuring the time interval between sending the signal and receiving the echo to determine the distance to an object.

Relay: Relay is an electrically operated switch. Current flowing through the coil of the relay creates a magnetic field, which attracts a lever and changes the switch contacts. The coil current can be on or off so relays have two switch positions and they are double throw (Change over) switches.

GSM Modem: A GSM modem is a wireless modem that works with a GSM wireless network. A wireless modem behaves like a dial-up modem. The main difference between them is that a dial-up modem sends and receives data through a fixed telephone line while a wireless modem sends and receives data through radio waves. Like a GSM mobile phone, a GSM modem requires a SIM card from a wireless carrier in order to operate.

Keypad: Another major peripheral used in the project. However unlike the LCD, this is an input peripheral. A 4x4 Keypad is used to input the numbers or string patterns that are all displayed on the LCD. It is also connected directly to the microcontroller. The keypad settings are configured within the code which is programmed into the microcontroller. It sends an 8 bit binary value for each button pressed which is

processed and converted into a character displayed on the LCD screen.

Liquid Crystal Display (LCD): Most common LCDs connected to the microcontrollers are 16x2 and 20x2 displays. This means 16 characters per line by 2 lines and 20 characters per line by 2 lines, respectively. The standard is referred to as HD44780U, which refers to the controller chip which receives data from an external source (and communicates directly with the LCD).

MAX232: Since the RS232 is not compatible with microcontroller 8051, we need a line driver (voltage converter) to convert the RS232's signals to TTL voltage levels that will be acceptable to 8051's TxD and RxD pins. A MAX232 IC does the same.

Electro-Mechanical Buzzer: A buzzer is in the mechanical form of a small rectangular or cylindrical housing, with electrical connection for direct mounting on rigid printed circuit. It requires a DC voltage to operate; it should generally be between 3 V and 28 V, depending on the model.

V. HARDWARE AND DESCRIPTION

Power Supply: Section For the working of the system a power supply is needed. The micro controller needs only 5 volt DC for its working. Therefore the incoming AC will be rectified filtered and regulated by 7805 IC.

89c51 Microcontroller Chip: The micro controller used for the implementation of this system is ATmega32. It is an 8-bit microcontroller with 32KB on-chip programmable flash memory. Based on the program stored in the micro controller it will generate the OTP. And if the passwords are matched or not, it will switch a relay also.

The GSM modem helps to send the generated OTP. OTP generation is the main part of this project. This is done by the micro controller. The RISC based micro controller consists of four ports. In which port A is dedicated for ADC.

Relay: It is basically a switch based on electromagnetic induction. Here uses a 12V DC SPDT relay. It is normally open and closes when the OTPs are the same.

Matrix Keypad: Here it is used for entering the password. A 4x4 matrix keypad is used.

LCD Display: For ease of interaction with the user, this system uses an electronic display module. Here a 16x2 LCD is used. This means in 2 lines it is possible to display 16

characters per line. A 5x8 pixel matrix is used for display one character. Two registers are associated with an LCD, such as data and command. These modules are preferred since it is easily programmable. For providing visual assistance to the lineman this module is unavoidable.

GSM MODEM: The Global System for Mobile Communication replaced the first generation analog cellular network. Here it is used for sending SMS to the user of the system that is the lineman. It is a dedicated modem device that accepts a SIM card and operates like a mobile phone. When it is used along with the computer, it is possible to communicate over the mobile network. Using serial communication the generated passwords are sent to the mobile phone of the user. Through the use of AT – attention commands the GSM modem can be controlled. It consists of an antenna.

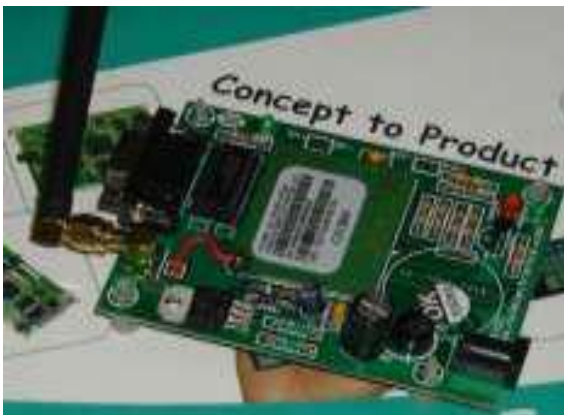

VI. CONCLUSION

It can work on a single given known password. No other person can reclose the breaker until the stored password is entered. It gives no scope of password stealing. It is effective in providing safety to the working staff. It is economical and it can be easily installed. Whenever the HT wire sag is higher than the predetermined range/value then ultrasonic sensor sends a message to the substation through GSM and intimates the operator about the trouble occurred. PIR sensor provides safety to human/animal by sensing their presence and alerting through a buzzer. It can be concluded that the proposed system can be used as an effective application in the present working system and provides safety to lineman and also corrective measures can be taken after HT wire sag intimation.

VII. FUTURE WORK

Instead of GSM 300 we can use GSM 900 which can be connected to IOT (internet of things). By using IOT we can operate the relays from any area as we can directly connect to

the server. Wireless ultrasonic and PIR sensors can be also used. We can use SCADA system, to help easy trouble shoot, to identify the fault location directly and line man can easily rectify it. We can also use EPROMS that can be interfaced to system so the circuit breaker cannot only operate from the substation, but also from other location through wireless communication.

VIII. RESULT

This proposed system provides a solution for ensuring the safety of maintenance personnel, such as linemen. The line man is the only one who has the ability to turn the line on and off. This system is set up in such a way that a password is required to operate the circuit breaker (ON/OFF). The lineman can turn off the supply and comfortably repair it before returning to the substation and turning on the line by entering People can change their passwords because it allows them to do so. Give any password he wants and his work will be completed.

This project can be used to ensure the safety of maintenance personnel, such as linemen. Only the line man has the ability to turn the line off and on. This system is configured in such a way that a password is required to operate the circuit breaker (ON/OFF). Linemen can safely turn off the power supply and repair it before resuming service by entering the correct password

REFERENCES

- [1] Electric Line Man Safety using Micro Controller with GSM Module IJSRD - International Journal for Scientific Research & Development| Vol. 4, Issue 01, 2016.
- [2] Electric Line Man Safety System with OTP Based Circuit Breaker IJRET: International Journal of Research in Engineering and Technology Volume: 04 Special Issue: 03 | INCEPTION-2015.
- [3] “The Microcontroller and Embedded systems” by Muhammad Ali Mazidi and Janice GillispieMazidi, Pearson Education.