

# Temporary Three Phase Fault Analysis With Auto Reset And Permanent Trip

Prof. Arvind Hirole<sup>1</sup>, Mukunda Rathod<sup>2</sup>, Avinash Jadhav<sup>3</sup>, Gaurav Nimbolkar<sup>4</sup>

<sup>1</sup> Assistant Professor, Dept of Electrical Engineering

<sup>2, 3, 4</sup> Dept of Electrical Engineering

<sup>1, 2, 3, 4</sup> Dr. VBKCOE, Malkapur, State Maharashtra, India

**Abstract-** This Project develops an automatic tripping mechanism for the three phase supply system. The project output resets automatically after a brief interruption in the event of a temporary fault while it remains in tripped condition in case of permanent fault. The advantages of the project is, it is not only save the appliance but it will also show the type of fault that has been occurred in the system so it will be easy for the operator to solve the problem easily. It will also check whether the fault is permanent or temporary fault. If the fault is temporary fault then the supply will be restored after a predefined time of 15sec otherwise permanent trip signal is given to the relay.

**Keywords-** LM 7805 Voltage regulator, Timer 555, comparator, Relays.

## I. INTRODUCTION

A fault in a power system is any failures which interface with the normal flow of current. The cause of electric power system faults is insulation breakdown. This breakdown can be due to a variety of different factors such as Lightning stroke

- Spray on Insulators
- Trees coming in contact with wires
- Equipment Failure
- Human Errors

As from the studies 70% to 90% of faults are occurred in overhead transmission line which are transient. There are many transient fault, such as damages of insulation, swinging wires and little time contact with other objects. These faults are cleared by operating the circuit breakers or can be cleared by de-energizing the line at short period for clearing the fault.

The other 30% to 10% faults are occurred in overhead line which are permanent or long duration fault. Permanent or long duration fault occurred by broken wire which results one phase to ground fault or joining the two phase together which is occurred in overhead line as well as in

the underground cable. These fault cleared by finding them in line and repair which results permanent trip of line.

## II. RESEARCH METHODOLOGY

### 2.1 Proposed System

Progressively easing Disappointment in three stage frameworks are very normal flaws experienced by three stage gadgets, disappointment of any stage will prompt drop in working voltage which will make either gadget quit working or three stage engine to run at lower voltages accordingly diminishing the speed and expanding vibration because of it. Our framework is intended to take care of this issue and thus saving the apparatus from harm. Utilizing mix of clock ICs we measure the time, when the stage flops then the heap is switched off right away, on the off chance that the stage returns before 8-10 seconds, the heap is turned on since the disappointment is distinguished as transitory, yet on the off chance that the hour of disappointment surpasses 8-10 seconds, it is treated as long-lasting disappointment as it can cause an issue in the heap associated so this time it is turned off forever, just when the client presses the reset button again the framework restarts. Subsequently, in the event of an impermanent shortcoming the result of the venture resets and if there should be an occurrence of extremely durable issue it gains long-lasting outing condition. This three-stage issue investigation framework naturally separates between a brief unsettling influence and a long-lasting shortcoming and suitably cuts the inventory for a brief span or long term individually.

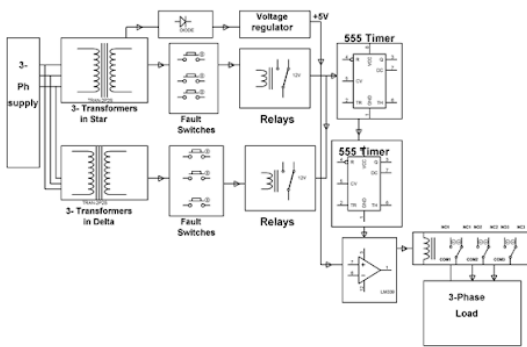

Fig -1: Three Phase Fault Analysis Block Diagram

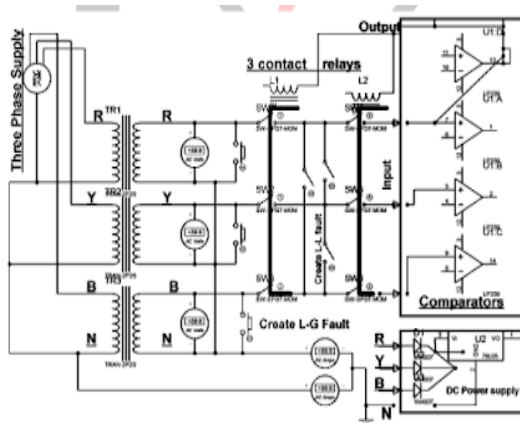

Fig -2: Three Phase Fault Analysis Circuit Diagram

### III. WORKING

There are six step down transformers which are connected to the board producing 12 volts to the circuit. These six transformers are divided into two groups, first one group is connected in star-star connection and later is connected in star-delta connection. The output of all the six transformers is rectified and filtered individually and are given to 6 relay coils. 6 push buttons one each connected across the relay coil is meant to create a fault condition. The NC contacts of all the relays are made parallel while all the common points are grounded. The parallel connected point of NC is then connected to pin2 of 555 timer through a resistor R5 i.e. wired in mono stable mode the output (pin3) of the same timer is connected to reset (pin4) of the other 555 timer wired in as table mode. LED's are connected at their output to indicate their status. The output (pin1) of 555 timer (U3) is given to op-amp LM358 through wire 11 and d12 (1N4007) to the non-inverting input (pin3) which acts as a comparator. It compares the value of pin 2 (inverting input) and pin 3 (non-inverting input) of LM358. The voltage of pin 2 is kept at fixed/constant voltage with the help of a potential divider. It is generally kept higher than the pin 3 of the operational amplifier so that pin 1 i.e. output of LM358 develops low (zero logic) which fails to

operate 3CO relay through the transistor Q, and the same is used for disconnecting the load used in fault condition.

### IV. ADVANTAGES

1. Advantages of three phase fault analysis with auto reset on temporary fault and permanent trip otherwise as follows:
2. This invention will accurately identifies hazardous faults requiring line de-Energization, and also accurately discriminates, or distinguishes, a hazardous fault from other events for which the line should remain energized.
3. The invention encompasses such a load analysis system which minimizes unnecessary power service interruptions and outages.
4. By using this system the secondary arc current can be abruptly reduced.
5. This system is even appropriate for long transmission line transmitting high voltage.
6. A timer is also provided to identify weather the fault is temporary or permanent. By doing so frequent tripping of the system can be avoided as temporary faults are self-correcting.
7. An individual re-closure to every phase so that if there is fault in any one phase then that phase only is deactivated keeping the other phases in working condition by doing so the efficiency of the system increases .
8. This invention provides relatively low cost and reliable apparatus for the intended purpose.
9. The invention will respond correctly to phase-ground faults occurring simultaneously on two of the three phase lines.
10. By using this proposed circuitry work should be completed from time to time . Also auto reclosing can significantly reduce the outage time due
11. to faults and provide a higher level of service continuity to the customer. It helps to maintain system stability.

### V. DISADVANTAGES:

If any fault occurs due to natural calamities then this invention will not able to overcome the fault.

### VI. RESULT

L-G and L-L faults have been created to develop an automatic tripping mechanism for the three phase supply system while temporary and permanent faults occur. Here timer 555 has been used with relay for the fault analysis short duration fault returns the supply to the load immediately called a temporary trip while long duration shall result in permanent trip as this project is advantageous compare to other protection

system it can be used for protection of transmission line faults which occur in power system hence this system is more economical, automatic and hazards free compared to other type of protecting system against three phase fault. This project design in the form of hardware for six single phase transformers to 230v to 12v of output to develop an automatic tripping mechanism for the three phase supply system while temporary fault and permanent fault occurs in the system. During a temporary fault it returns the supply to the load immediately, otherwise it results in a permanent trip.

## VII. CONCLUSION

Various faults have been created to develop an automatic tripping mechanism for the three phase supply system while temporary and permanent fault occur. Here timer 555 has been used with relay for the fault analysis short duration fault returns the supply to the load immediately called a temporary trip while long duration shall result in permanent trip as this project is advantageous compare to other protection system it can be used for protection of transmission line faults which occur in power system hence this system is more economical, automatic and hazards free compared to other type of protecting system against three phase fault.

## REFERENCES

- [1] IEEE Power System Relaying Committee; Automatic Reclosing of Transmission Lines; IEEE Transactions, Vol. PAS-103, Feb1984, no. 2, pages 234-345.
- [2] Protection Relay Application Guide; GEC Measurement, 1975
- [3] Three Phase Auto Recloser Scheme; Nagar D Singh Bhalla D Paliwal D; IJSRD –International Journal for Scientific Research & Development; 2016 vol: 4 (01online) pp: 2321-613
- [4] Three Phase Fault Analysis with Auto Reset for Temporary Fault and Trip for Permanent Fault; Bakanagari S Kumar A CheenyaM; Journal of Engineering Research and Applications.
- [5] Tahir, A., Tosi, D., Morasca, S.: ‘A systematic review on the functional testing of semantic web services’, J. Syst. Softw., 2019, 86, (11), pp. 2877– 2889.
- [6] Nie, C., Wu, H., Niu, X., et al.: ‘Combinatorial testing, random testing, and adaptive random testing for detecting interaction triggered failures’, Inf. Softw. Technol., 2020, 62, (1), pp. 198–213.
- [7] Ivaki, N., Laranjeiro, N., Araujo, F.: ‘A survey on reliable distributed communication’, J. Syst. Softw., 2020, 137, pp. 713–732