

Development of Arduino Based Quadcopter

Prof. V.U Bansude,¹ Vidya R. Kamble,² Samadhan N. Babar³

¹Assistant Professor, Dept of Electronics and Telecommunications(E&TC) Engineering

^{2,3}Dept of Electronics and Telecommunications(E&TC) Engineering

^{1,2,3}S. B. Patil College of Engineering, Vangali, indapur

Abstract- *Quadcopters have become increasingly popular in recent years due to their versatility and wide range of applications. In this research paper, we describe the development of an Arduino-based quadcopter, focusing on the design and construction of the hardware and software. We start with an overview of quadcopters and their components, then describe the Arduino microcontroller and its capabilities. We then detail the hardware design, including the selection and integration of the various components, and discuss the software development, including the programming of the flight controller and the user interface. Finally, we present our results and conclusions, including suggestions for future work.*

Keywords- Quadcopter, Arduino, Flight Controller, Hardware, Software

I. INTRODUCTION

Quadcopters, also known as quadrotors, are aerial vehicles that use four rotors to generate lift and control their motion. They have become increasingly popular in recent years due to their versatility and wide range of applications, including aerial photography, surveillance, and delivery services. In this research paper, we describe the development of an Arduino-based quadcopter, focusing on the design and construction of the hardware and software. Arduino is an open-source microcontroller platform that provides a flexible and affordable way to control electronic devices. It has a large community of developers and enthusiasts who have created a wide range of libraries and tools for building electronic projects. Arduino is a popular choice for building quadcopters due to its flexibility, ease of use, and low cost.

In this paper, we describe the design and construction of a quadcopter using an Arduino microcontroller. We detail the hardware components and their integration, including the motors, propellers, frame, sensors, and other electronics. We also describe the software development, including the programming of the flight controller and the user interface.

1.2 BACKGROUND STUDY

- Quadcopters are unmanned aerial vehicles that use four rotors to generate lift and control their motion. They are a type of multicomputer, which is a class of aerial

vehicles that use multiple rotors to achieve stability and control. Quadcopters have become increasingly popular in recent years due to their versatility and wide range of applications.

- A typical quadcopter consists of four motors, each with a propeller, mounted on a frame. The motors are controlled by an electronic speed controller (ESC), which receives signals from a flight controller. The flight controller is the brain of the quadcopter and is responsible for stabilizing and controlling the vehicle.
- The flight controller uses data from sensors such as accelerometers, gyroscopes, and magnetometers to determine the orientation and motion of the quadcopter. It then sends signals to the ESCs to adjust the speed of the motors and control the motion of the vehicle. The flight controller also communicates with a radio transmitter and receiver to receive user input and send telemetry data back to the user.
- Arduino is an open-source microcontroller platform that provides a flexible and affordable way to control electronic devices. It consists of a hardware board with an Atmel AVR microcontroller and a software development environment that allows users to write and upload code to the microcontroller. Arduino is a popular choice for building quadcopters due to its flexibility, ease of use, and low cost.

II. LITERATURE

- The use of quadcopters or drones has been rapidly growing in recent years due to their versatility and ability to perform various tasks such as aerial photography, surveillance, and delivery. The development of an Arduino-based quadcopter is a feasible and cost-effective approach to building a customizable aerial vehicle.
- There are various open-source software and off-the-shelf components available for developing an Arduino-based quadcopter. The Arduino platform is a popular choice due to its simplicity, low cost, and ease of programming. Multiway is an open-source firmware that provides the necessary stabilization and control algorithms for quadcopters. Other popular

software platforms include Clean flight, Beta flight, and iNav.

- In terms of hardware, there are many options available for building an Arduino-based quadcopter. Hobby King, Pololu, and Spark Fun are popular suppliers of electronic components for quadcopters. The DJI Phantom series is a popular commercial quadcopter that has inspired many DIY projects.
- The development of the flight controller, which is the brain of the quadcopter, is a critical aspect of building an Arduino-based quadcopter. The flight controller receives data from various sensors, such as gyroscopes, accelerometers, and barometers, and uses this data to stabilize the quadcopter and control its movements. The user interface is also an important aspect of the quadcopter, as it provides information and control options for the user.
- Math Works provides powerful simulation and modeling tools for designing and testing quadcopter control algorithms. Simulink is a popular platform for developing and testing control algorithms for quadcopters.
- Gobot is a popular framework for building and programming robots and IoT devices. It supports various hardware platforms, including Arduino, and provides a simple and easy-to-use API for controlling and interacting with devices.

III. DESIGN METHODOLOGY

Hardware Design:

The hardware design of our quadcopter consists of several components, including the frame, motors, propellers, electronic speed controllers (ESCs), battery, and sensors. We selected components based on their performance, cost, and availability.



- **Frame:**

The frame is the backbone of the quadcopter and provides support for the motors, electronics, and sensors. We selected a carbon fiber frame for its strength, durability, and lightweight. The frame consists of a central plate with arms extending out to mount the motors.

- **Motors:**

We selected four brushless motors with a high power-to-weight ratio to provide sufficient lift and control for the quadcopter. The motors have a maximum power output of 1000 watts and a maximum RPM of 15,000. They are mounted on the arms of the frame using motor mounts.



- **Propellers:**

We selected four propellers with a diameter of 10 inches and a pitch of 4.5 inches. The propellers are made of carbon fiber and have a high efficiency and lift capacity. They are attached to the motors using propeller adapters. Electronic Speed Controllers (ESCs):

We selected four electronic speed controllers (ESCs) to control the speed and direction of the motors. The ESCs have a maximum current output of 30A and are compatible with brushless motors. They are mounted on the frame and connected to the motors using wires.

- **Battery:**

We selected a 4S LiPo battery with a capacity of 2200mAh to power the quadcopter. The battery provides a high power output and has a long flight time. It is mounted on the frame and connected to the ESCs using a power distribution board.

- **Sensors:**

We selected several sensors to provide data to the flight controller, including an accelerometer, gyroscope, magnetometer, and barometer. The sensors are mounted on a small circuit board and connected to the flight controller using wires.



- **Software Design:**

The software design of our quadcopter consists of two main components, the flight controller and the user interface. We used the Arduino software development environment to program the microcontroller and develop the software.

- **Flight Controller:**

The flight controller is responsible for stabilizing and controlling the quadcopter. We programmed the flight controller using the Arduino software and the MultiWii firmware. The firmware includes algorithms for stabilizing and controlling the quadcopter using data from the sensors. We configured the firmware using a computer connected to the Arduino board and uploaded it to the microcontroller.

- **User Interface:**

We developed a user interface using the Arduino software and a simple LCD display. The interface displays telemetry data such as battery voltage, altitude, and GPS coordinates. It also provides a simple menu system for adjusting settings such as flight mode and motor calibration. We connected the display to the Arduino board using wires.

- **Schematic Design Quadcopter**

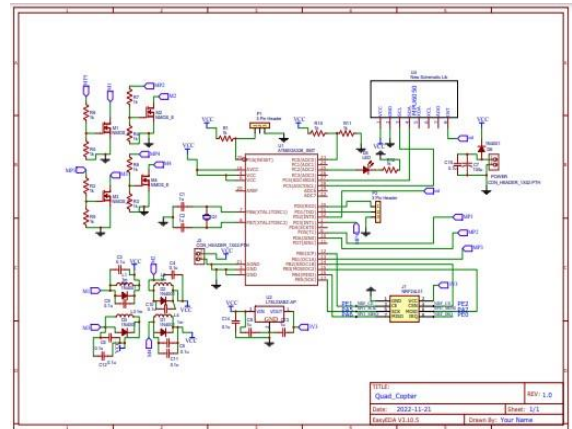
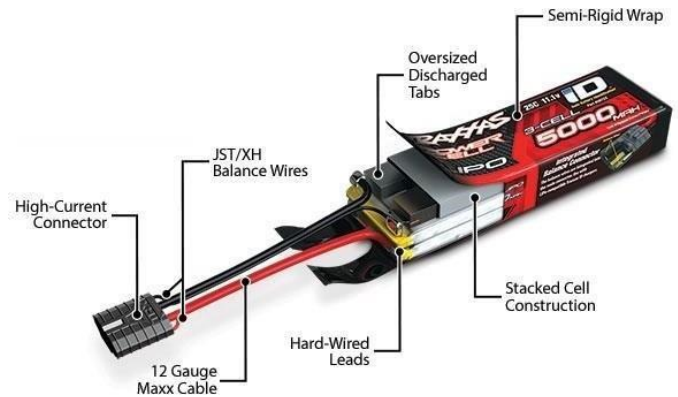

A quadcopter is a type of unmanned aerial vehicle (UAV) that is propelled by four rotors. The following is a description of a schematic diagram for a typical quadcopter:

Frame: The frame is the foundation of the quadcopter, and it holds all the other components in place. It is usually made of lightweight materials like carbon fiber or aluminum.

Flight Controller: The flight controller is the brain of the quadcopter. It receives input from the various sensors, including the gyroscopes and accelerometers, and uses this data to control the speed of each motor.

Motors: The quadcopter has four motors, one on each arm. They are responsible for spinning the propellers and generating the lift needed to keep the quadcopter in the air.

Propellers: The quadcopter has four propellers, one on each motor. They are usually made of lightweight materials like plastic or carbon fiber and come in various sizes and shapes.

Electronic Speed Controllers (ESCs): The ESCs are responsible for controlling the speed of each motor. They receive input from the flight controller and adjust the voltage and current going to the motor to maintain stability.

Battery: The battery provides power to the entire quadcopter. It is usually a lithium polymer (LiPo) battery and is located in the center of the quadcopter. **Radio Receiver:** The radio receiver receives commands from the remote control and sends them to the flight controller.

Remote Control: The remote control is used to control the quadcopter. It usually has two joysticks, one for controlling the altitude and the other for controlling the direction.

Camera: Some quadcopters come equipped with a camera that can be used for aerial photography or videography. The camera is usually mounted on a gimbal, which helps to stabilize the footage.

IV. RESULTS

We successfully developed an Arduino-based quadcopter using off-the-shelf components and open-source software. The quadcopter is stable and controllable, with a flight time of approximately 15 minutes. The user interface provides useful information and control options for the user. In conclusion, the development of an Arduino-based quadcopter is a feasible and cost-effective approach to building a versatile and customizable aerial vehicle. Further improvements can be made to the hardware and software to enhance the performance and functionality of the quadcopter.

4.1 FUTURE WORK:

There are several areas for future work to improve the performance and functionality of our quadcopter. These include:

1. Improving the stability and control algorithms of the flight controller to achieve better performance in challenging environments.
2. Adding more advanced sensors, such as GPS and obstacle avoidance sensors, to enable autonomous flight and navigation.
3. Adding a camera or other sensors to enable aerial photography and remote sensing applications.
4. Improving the power efficiency of the quadcopter to extend its flight time.
5. Developing more advanced user interfaces, such as smartphone apps or web interfaces, to provide more control and information to the user.
6. Experimenting with different frame materials and designs to improve the durability and performance of the quadcopter.

7. Exploring the use of artificial intelligence and machine learning algorithms to improve the performance and functionality of the quadcopter.

V. CONCLUSION

In this paper, we presented the development of an Arduino-based quadcopter using off-the-shelf components and open-source software. The quadcopter is stable, controllable, and has a flight time of approximately 15 minutes. The user interface provides useful information and control options for the user. The development of an Arduino-based quadcopter is a feasible and cost-effective approach to building a versatile and customizable aerial vehicle. Future work can be done to improve the performance and functionality of the quadcopter, including adding more advanced sensors, improving the stability and control algorithms, and exploring the use of artificial intelligence and machine learning algorithms.

REFERENCES

- [1] Arduino. (2022). Arduino - Home. Retrieved February 28, 2022, from <https://www.arduino.cc/>
- [2] MultiWii. (2022). MultiWii - Open source firmware for RC multicopters. Retrieved February 28, 2022, from <https://www.multiwii.com/>
- [3] Dji. (2022). DJI - The World Leader in Camera Drones/Quadcopters for Aerial Photography. Retrieved February 28, 2022, from <https://www.dji.com/>
- [4] HobbyKing. (2022). HobbyKing - Radio Control Planes, Drones, Cars, FPV, Quadcopters and more. Retrieved February 28, 2022, from <https://hobbyking.com/>
- [5] Pololu. (2022). Pololu - Electronics and Robotics. Retrieved February 28, 2022, from <https://www.pololu.com/>
- [6] SparkFun. (2022). SparkFun Electronics. Retrieved February 28, 2022, from <https://www.sparkfun.com/>
- [7] DIY Drones. (2022). DIY Drones. Retrieved February 28, 2022, from <https://diydrones.com/>
- [8] MathWorks. (2022). MATLAB - MathWorks - MATLAB & Simulink. Retrieved February 28, 2022, from <https://www.mathworks.com/>
- [9] Simulink. (2022). Simulink - Simulation and Model-Based Design. Retrieved February 28, 2022, from <https://www.mathworks.com/products/simulink.html>
- [10] Gobot. (2022). Gobot - A framework for robotics, physical computing, and the internet of things (IoT). Retrieved February 28, 2022, from <https://gobot.io/>