

# Review on EV Charging Station With on Grid Green Power And Wireless Charging

Mr. Vishal Narkhede<sup>1</sup>, Prof. Y. P. Sushir<sup>2</sup>, Mr. Shreyash Patil<sup>3</sup>, Mr. Dipak Kharate<sup>4</sup>,  
Mr. Onkar Choudhari<sup>5</sup>, Miss Aishwarya More<sup>6</sup>, Miss. Shweta Hingmire<sup>7</sup>

<sup>1, 2, 3, 4, 5, 6, 7</sup>Dept of Electrical Engineering

<sup>1, 2, 3, 4, 5, 6, 7</sup>Padm. Dr. V. B. Kolte College of Engineering, Malkapur

**Abstract-** In this paper we are introducing an updated version of charging of batteries through renewable energy grids. The major sources of this charging by solar panels and wind turbine. A voltage regulator is used to produce a constant voltage at the output side. Buck-Boost converter is used to convert the low voltage DC [LVDC] to high voltage DC [HVDC]. A rectifier circuit is used only at the output of wind turbine which rectify the harmonics produced. This power is stored in the battery. The output of this battery can be used for any type of electrical components. However, we are using a switching mechanism used at the battery side which makes sure that output from the batteries will be continuous. This project also presents wireless charging of electric vehicle [EV] mainly focusing on resonant technology. The main goal is to transmit power using wireless power charging with the maximum efficiency at a low cost. The power is transmitted through resonance coupling. This technology uses mutual inductance which is standard. The energy sources of this system are solar and wind energy. Use of Buck-Boost converter, voltage regulator with C smoothing. Finally transmitting coil coupled with battery at both the end of these coil.

**Keywords-** Solar Panels, Wind Turbine, Buck-Boost Converter, Resonance Coupling, Mutual Inductance.

## I. INTRODUCTION

Electric vehicles (EVs) have become the era-defining technology in the context of fuel economy and energy efficiency. The acquired technology in the EV sector will be one of the major contributing factors determining the growth rate of countries. Though EVs were introduced about 100 years before, the hike in interest is due to the inclining fuel price and awareness about energy conservation. As a set of breakthroughs were made initially, it is hard to identify the inventor of EVs. At the beginning of the century, pioneers of the United States, Hungary and Netherlands began experimenting with the perception of battery-powered cars and succeeded in making some prototypes. During the second half of the 19th century, English and French engineers implemented the first practical prototype of an EV including

the electric crude carriage by Robert Anderson. The first EV of the United States was invented by William

Morrison in 1890, with a six-passenger vehicle having 14 miles per hour maximum speed. Over the following decade, EVs from various countries began to emerge. However, the introduction of internal combustion engines during the end of the 19th century leads the EV sector to a freeze point. However, the engineers never stopped their endeavours towards EVs. The EV model P1 introduced by famous sports car manufacturer Ferdinand Porsche in 1898 started a new era of explorations. He created the world's first hybrid car at the same time. World-renowned scientist Thomas Edison collaborated with famous car manufacturer Henry Ford and implemented a low-cost EV in 1914. Nevertheless, the low cost and highly reliable gasoline cars ruled the transportation sector in the 20th century. At the end of the 20th century, the hike in gasoline price and escalated regulations regarding air pollution encouraged the EV sector. Still, compared to the gasoline vehicles, the starting torque and running range were very low. Two initiatives at the beginning of the 21st century laid the foundation of the modern EV boom. The first initiative was by Toyota Prime of Japan, which is the first widely produced hybrid EV in the history of vehicles. Prime made its debut in the transportation sector in 1997. A later breakthrough was the entry of Silicon Valley startup, Tesla into the luxury electric sports car sector in 2006. Within a short period, Tesla changed the EV scenario, which encouraged various vehicle manufactured for EV implementation and shaped the industry, as it seems today. Even though wired power transfer energises most of the primitive EVs, inventors were concerned by the incompatibility of the same. As initiatives towards wireless power transfer already started at the beginning of the 90 s, they began the pursuit of powering EVs with wireless power.

## II. LITERATURE REVIEW

- **Matjaz Rozman, Augustine Ikpehai (2019) et. al.** This paper presents a novel localization method for electric vehicles (EVs) charging through wireless power transmission (WPT). With the proposed technique, the

wireless charging system can self determine the most efficient coil to transmit power at the EV's position based on the sensors activated by its wheels. To ensure optimal charging, our approach involves measurement of the transfer efficiency of individual transmission coil to determine the most efficient one to be used. This not only improves the charging performance but also minimizes energy losses by autonomously activating only the coils with the highest transfer efficiencies.

- **Jaime Garnica, Raul A. Chinga and Jenshan Lin (2020) et. al.** Wireless power has been a topic of interest from the early 20th century until today. This paper traces the history of wireless power transmission starting with Nikola Tesla, continuing on to experiments with beaming power using microwaves. Examining the difference between near-field and far-field techniques, this paper continues into modern times explaining why near-field technique is more suitable for consumer electronic devices and exploring the near-field transmission of power via the magnetic field. Examples of short-range and midrange wireless power systems are explored.
- **Shashank Prakash Naidu (2022) et. al.** In this paper we are introducing an updated version of charging of batteries through renewable energy grids. The major sources of this charging by solar panels and wind turbine. A voltage regulator is used to produce a constant voltage at the output side. Buck-Boost converter is used to convert the low voltage DC[LVDC] to high voltage DC[HVDC]. A rectifier circuit is used only at the output of wind turbine which rectify the harmonics produced. This power is stored in the battery. The output of this battery can be used for any type of electrical components. However, we are using a switching mechanism used at the battery side which makes sure that output from the batteries will be continuous.
- **Gautham Ram Chandra Mouli, Peter Van Duijsen, Francesca Grazian (2019) et. al.** If electric vehicles have to be truly sustainable, it is essential to charge them from sustainable sources of electricity, such as solar or wind energy. In this paper, the design of solar powered e-bike charging station that provides AC, DC and wireless charging of e-bikes is investigated. The charging station has integrated battery storage that enables for both grid-connected and on grid operation. The DC charging uses the DC power from the photovoltaic panels directly for charging the e-bike battery without the use of an AC charging adapter.
- **Syed Ali Kashani, Alireza Soleimani, Ali Khosravi (2021) et. al.** Within the past decade, since impediments in nonrenewable fuel sources and the contamination they cause, utilizing green energies, such as those that are sun-oriented, in tandem with electric vehicles, is a developing

slant. Coordinating electric vehicle (EV) charging stations with sun-powered boards (PV) reduces the burden of EV charging on the control framework. This paper presents a state-of-the-art literature review on remote control transmission frameworks for charging the batteries of electric vehicles utilizing sun-based boards as a source of power generation. The goal of this research is to advance knowledge in the wireless power transfer (WPT) framework and explore more about solar-powered electric vehicle charging stations.

### III. METHODOLOGY

Domestic motor vehicle sales in India during 2016-17 included 3.05 million passenger vehicles, 0.71 million commercial vehicles, 0.51 m three Wheelers and 17.59 two-Wheelers. The luxury car segment is relatively small with sales of just over 40,000 cars in 2018. The total number of registered motor vehicles reached approx. 230 million in March 2016. The India government envisage the number of EV's to be rapidly increase and also expecting the achievement of complete electric mobility by the year 2030. Rapid growth in the sales of EV's correlate to the rising demand of electricity, which would encourage the government more likely to implement fossil fuel, powered generating stations. Hence, this act would also contribute to harmful emission to the environment. The primary solution for the above crisis would be the dependency on renewable energy resources. Therefore, here in this project a solar powered grid connected system with charging capabilities for electric auto rickshaw is designed. The project discusses the effect of solar generation through proper result analysis. Distribution of PV Modules is studied. Load profile of electric vehicle is established to prepare the dependency to the grid power. The figure 1 shows the overall picture and the figure 2 shows the block diagram of the PV plant. The usage of such kind of automatic street lights can avoid unwanted loss of energy from the human errors. The motive of the project as a whole is to preserve the energy generated and to replace the existing system with collective sustainable sources.

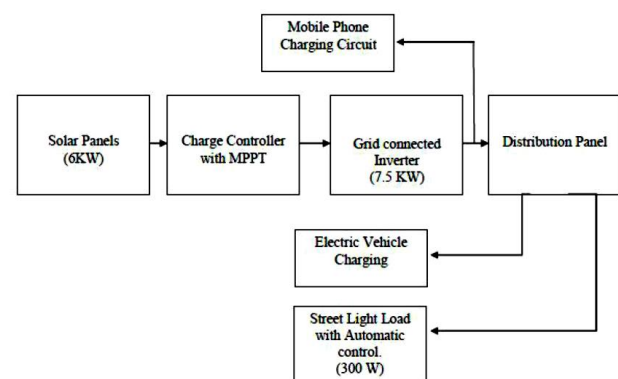

Fig. 1 Block diagram of the proposed system

Lights in the Bus station can be automated to operate in the evening, which includes three 100W Street LED Lights, with a required capacity of 300W. Hence, the system is capable of covering a demand of approximately 6-7.5 kW. The figure 3.1 shows the overall picture and the figure 3.2 shows the block diagram of the PV plant. The usage of such kind of automatic streetlights can avoid unwanted loss of energy from the human errors. The motive of the project as a whole is to preserve the energy generated and to replace the existing system with collective sustainable sources.

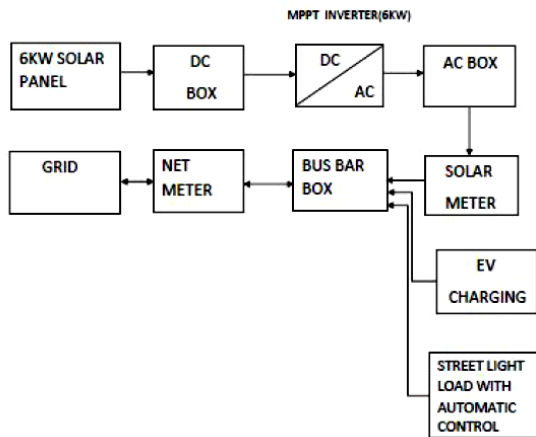

Fig. 2: Block diagram of PV plant

Electric vehicle industry as a rising field of technology enhances passages for other sectors to build up with this. Here come the importance of the charging infrastructure development and its priority in maintaining the life cycle of electricity production. The system as proposed indicates a green energy signal through which incorporates sustainable energy to a charging infrastructure. The design explained here induces a profound importance of integrating such sustainable sources and providing customer friendly necessary services within them. As part of this section, it is evidently put forward the idea of developing such a charging infrastructure which could be in par with the nature. The system also provides Mobile phone charging outlet and automatic street light system with it.

IV. SIMULATION

The primary solution for the crisis would be the dependency on renewable energy resources. Therefore, here in this project a solar powered grid connected system with charging capabilities for electric auto rickshaw is designed. The project discusses the effect of solar generation through proper result analysis.

A. Simulation of Solar System

A Solar Powered Grid connected Charging station is considered, where a 6 kW solar system is selected for performance study. The system is to be installed Chinnakada, Kollam, Kerala India for facilitating provision for charging of electric auto rickshaw operators. The integration of Solar panel compensates the energy supplied to the load from the grid. The 6kW system is chosen considering the load profile of the electric auto available within the described area. The system is capable of extending the capacity to meet future demand.

B. Simplified schematic diagram

PV Array is capable of generating a certain required demand. As the system is grid tied, excess requirement is compensated by utilizing sufficient power from the grid supply. The overall schema is distributed into three subsystems P Array, System, User/ Load.

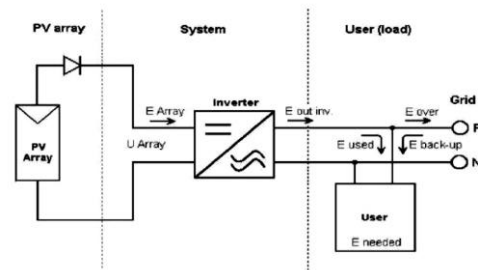

Fig. 3 Simplified Schematic diagram

C. Load profile

The charging station is designed to suit for electric auto's, load profile varies between 4.8 to 5.4 kW. Simultaneous usage of multiple load was also considered with a maximum value up to 10.8 kW. The daily load profile of e-autos from our observation is shown in the Table represent the daily load graph.

Table 1: Load profile

Time	0	1	2	3	4	5	6	7	8	9	10	11
Load (KW)	0.0	0.0	0.0	0.0	0.0	10.2	0.0	0.0	0.0	0.0	0.0	5.4
Time	12	13	14	15	16	17	18	19	20	21	22	23
Load (KW)	4.8	0.0	0.0	0.0	0.0	0.0	5.4	4.8	0.0	0.0	0.0	0.0

V. SYSTEM COMPONENTS

A. Solar PV system

The items required for Solar PV system is listed in Table

**Table 2: List of items for Solar PV System**

Description of Supply Item	Qty	Make
Solar PV Module	6 KW	Tata Power Solar Approved
Module Mounting Structure	1	Tata Power Solar Approved
Grid Connect Solar Three Phase Inverter- 6 kw	1	Tata Power Solar Approved
Data Monitoring System	1	Tata Power Solar Approved
Array Junction Box	As Req.	Tata Power Solar Approved
AC Distribution Board with isolators	As Req.	Tata Power Solar Approved
Cables	15 m	Tata Power Solar Approved
Earthing Kit, Wire & GI Earth Strip	1	Tata Power Solar Approved
Installation Kit	1	Tata Power Solar Approved

### B. Solar Panels

A PV module is an assembly of photo-voltaic cells mounted in a frame work for installation. Photo-voltaic cells use sunlight as a source of energy and generate direct current electricity. A collection of PV modules is called a PV Panel, and a system of Panels is an Array. Arrays of a photo voltaic system supply solar electricity to electrical equipment. By considering our 6kW requirement we are installing 18 solar panels of 335W rating each and the optimum tilt angle for the panel is 15 degree.

**Fig. 4 Solar Modules, 325W/330Wp Multi crystalline**

### C. Solar Inverter

A solar inverter or PV inverter, is a type of electrical converter which converts the variable direct current (DC) output of a photo voltaic (PV) solar panel into a utility frequency alternating current (AC) that can be fed into a commercial electrical grid or used by a local, electrical

network. Here we use a 6KW On-Grid Connected, Three Phase Solar Inverter with inbuilt MPPT. Maximum power point tracking (MPPT) is a technique used commonly with wind turbines and photo voltaic (PV) solar systems to maximize power extraction under all conditions. Figure 3.6 shows the Growatt Grid Connect Solar String Three Phase Inverter- 6 KW.

**Fig. 5 Growatt Grid Connect Solar String Three Phase Inverter- 6 KW**

### D. Three phase net meter

Net metering is an agreement that allows the solar PV system owner to sell excess solar energy to the utility company or buy deficit energy from the utility company using a meter to track this energy exchange. The loads can run on solar power as long as there is sufficient energy available from the sun during the day. Any deficit is taken care by the main utility supply. However, if the solar energy production is in excess as compared to the load requirement at that moment, the excess energy can be transferred back to the utility grid. This difference of energy is tracked and maintained in Net Meter. Range: 10-60A in Accuracy Class-1. 4 quadrant meter with pulse output LED's for kWh & kVArh. Separate readings for Active Energy kWh, kVAh Import & Export. Net Energy kWh with sign. Figure 3.7 shows the picture of Net meter.

**Fig. 6 Net meter**

### E. EV Charger

The figure shows the image of the charging unit. In this unit contain the following things,

- Compliant with Bharath EV Charging Standards
- Number of Outputs: 3, 230V -15A single phase each
- IEC 60309 based charging connectors

- Metering using certified Energy Meter for compliance with Indian Standards
- Large 7-inch Touch Screen display for a straight forward user experience
- Ingress protection category: IP-54

#### F. Advantages

- Renewable energy source.
- One of the most significant advantages of solar-powered charging stations is that they use renewable energy from the sun to recharge EVs.
- Reduced carbon footprint.
- Reduce dependence on nonrenewable energy sources.
- Low-cost energy source.

#### G. Disadvantages

- Power outputs vary between charging stations, but DC fast chargers can deliver between 7 and 50 times more power than a regular AC charging station. While this high power is great for quickly topping up an EV, it also generates considerable heat and can put the battery under stress.
- Wireless charging for electric vehicles offers several advantages, including convenience, enhanced safety, and environmental sustainability. However, challenges such as lower efficiency, higher implementation costs, and standardization issues need to be
- Power outputs vary between charging stations, but DC fast chargers can deliver between 7 and 50 times more power than a regular AC charging station. While this high power is great for quickly topping up an EV, it also generates considerable heat and can put the battery under stress.

### VI. CONCLUSION

The movement of automobile sector from conventional fossil fuelled vehicles to Electric vehicles are drastically increased. There is a requirement for more electric vehicles charging station in the roadsides of highways in regular intervals like the petrol pumps now. This electric charging increases the needs of more electricity. If the demand of electricity increases the respective department want to produce more electricity by hydro-power plant, thermal plants, etc. The use of fossil fuels also leads to environmental pollution. So we need a grid connected solar powered electric vehicle charging station. This can reduce the cost of battery for store charge in day time and provide charge for charging in

night time, the efficiency of battery is also small. So by eliminating batteries we can improve the performance.

### REFERENCES

- [1] A.R.Bhatti and Z.Salam, "Photovoltaic (PV) Charging of Electric Vehicle (EV)", in Conference: Electrical Engineering Research Colloquium (EERC-2013), At Faculty of Electrical Engineering, University Teknologi Malaysia (UTM), Malaysia, Volume: 1, 2013
- [2] D. P. Birnie III, "Solar-to-vehicle (S2V) systems for powering commuters of the future" *Journal of Power Sources*, 186(2), 2009, pp. 539-542
- [3] S. Lee, P. Shenoy, D. Irwin and S. Iyengar, "Shared Solar-powered EV Charging Stations: Feasibility and Benefits", 7th IEEE International Green and Sustainable Computing Conference, 2016.
- [4] Yilmaz M, Krien PT. Review of battery charger topologies, charging power levels, and infrastructure for plug-in electric and hybrid vehicles, *IEEE Trans Power Electron.* 2013;28(5):2151-2169
- [5] Faucett WA, "Electric Vehicle conductive charging system { part 1: general requirements", *Genet Test Mol Biomarkers.* 2010;14(5);585
- [6] Ahamed A, Saad Alam M, Chabaan R, "A comprehensive review of wireless charging technologies for electric vehicles", *IEEE Transactions on Transportation Electrification* 2017:1-1
- [7] Qiu C, Chau KT, Liu C, et al. "Overview of wireless power transfer for electric vehicle charging", 2013 World Electric Vehicle Symposium and Exhibition (EVS27), 2013 ;7:1-9
- [8] Mak H-Y, Rong Y, Shen Z-JM. "Infrastructure planning for electric vehicles with battery swapping". *Management Science, SSRN Electron J.* 2012.