

Non Linear Analysis of Beam Column Joint With Geopolymer

Mr. Vaibhav Piraji Janke¹, Prof. Dr. L. G. Patil²

¹Department of Civil Engineering

²Associate Professor, of Civil Engineering

^{1,2}Shri Guru Gobind Singh ji institute of engineering and technology, Vishnupuri, Nanded-431 606

Abstract- *The ancient Romans used concrete and poured it into moulds to construct a sophisticated network of aqueducts, culverts, and tunnels. Pre-cast technology is now used in a range of architectural and structural applications, from individual components to full building systems. When an earthquake strikes a reinforced concrete structure, the beam-column junctions are critical zones. Due to the huge stresses and moments generated by significant ground shaking, concrete in the joint location cracks diagonally and crushes. Thus, for the design of beam-column junctions, extremely ductile materials are necessary. There are three types of beam-column joints: interior, exterior, and corner. The purpose of this research is to analyse RCC buildings for dead loads, live loads, and earthquake loads in order to identify critical joints and to analyse critical joints in ANSYS for axial forces, shear forces, and bending moments, as well as the impact of utilising a geopolymer layer.*

Keywords- Beam Column Joint, Geo-polymer, Non Linear Analysis, ANSYS, Staad Pro

I. INTRODUCTION

General:

The beam-column joints are the crucial zones when a reinforced concrete building experiences an earthquake. The large forces and moments produced during severe ground shaking leads to diagonal cracking and crushing of concrete in the joint region. Thus, highly ductile materials are required for the design of beam-column joints. Beam-column joints can be classified into interior, exterior and corner joints. The longitudinal bars of a beam need to be anchored into the column to ensure a proper grip, especially in the case of exterior beam-column joints. The capacity of the beam in an exterior joint is governed by the moment created by shear capacity of beam rather than its flexural capacity.

Geopolymer concrete is earning attention nowadays for its low CO₂ emissions and as a sustainable alternative to ordinary portland cement. The term "geopolymers" was first

coined by Joseph Davidovits in 1978 to classify a Three-Dimensional (3D) polymeric network of alumino-silicate binders. An alkaline activator solution is used in the geopolymerisation reaction which acts as a catalytic liquid system. GPC can be cured under ambient conditions thus reducing the usage of water compared to conventional curing methods. Heat cured specimens gained strength immediately but more compressive strength was obtained for specimens which were cured in ambient conditions. A combination of Sodium Silicate (Na₂SiO₃) and Sodium Hydroxide (NaOH) solutions are commonly used in the production of Geopolymer Concrete (GPC). The compressive strength of GPC specimens increased with the increase in concentration of NaOH so GGBS and fly-ash are the most commonly used source materials in the production of GPC. The usage of GGBS and dolomite together as binders is a comparatively new method in the production of GPC. Ground Granulated Blast Furnace Slag (GGBS) is a by-product released from the blast furnaces of the iron industry. It is evident from the experimental studies that inclusion of GGBS enhances concrete workability, durability, density, compressive strength and reduces the setting time. Dolomite is a by-product from rock crushing industry and contains higher CaO content which can significantly improve the strength of concrete. However, it has never been used in the production of GPC. Hence, it is expected that inclusion of dolomite for preparing geopolymer concrete can yield some better results and reduce its disposal problem as well.

The present study aims to evaluate the behaviour and performance of steel fibre reinforced dolomite-GGBS geopolymer concrete beam-column joints under monotonic loading using finite element methods. Beam-column joints are modelled by using the Finite Element Method [FEM]-ANSYS to evaluate the response of joints under monotonic loading. Non-linear analysis has been carried out to study the behaviour of the beam-column joint models under gradually increasing monotonic load applied at the bottom of the free end of the beam. The crack/crush patterns, deflections and stresses at various points were evaluated for steel fiber reinforced GPC. lution ratio of Na₂SiO₃, to NaOH solutions, mixing time, curing time and curing temperature.

1.1 OBJECTIVES

The objectives of this study are specifically given as following.

1. To perform analysis of RCC building for Dead load, live load and Earthquake load to identify Critical joint.
2. To Perform analysis of critical joint for axial forces, shear forces and Bending moment in ANSYS and its effect using Geopolymer layer
3. Comparative analysis of beam column connection using Geopolymer with RCC beam column connection for bending stresses, shear stresses, principal stresses and Deflection
4. To investigate the important aspects of GFRP bars in geopolymer concrete, the flexural and shear behaviour of geopolymer concrete beams longitudinally and transversely reinforced with GFRP bars and stirrups, respectively, and the compression behaviour of geopolymer concrete columns internally reinforced with GFRP bars and ties.

II. LITERATURE REVIEW

A Survey of work done in the research area and need for more research

2.1 June, M. (2017).

Beam and column where intersects is called as joint or junction. The different types of joints are classified as corner joint, exterior joint, interior joint etc. on beam column joint applying quasi-static loading on cantilever end of the beam and study of various parameters as to be find out on corner and exterior beam column joint. The focus of our project is T-shaped concrete frame connection. There was minimum damage on the concrete column and joint panel zone. For a specimen with strong beams-weak columns, there was local buckling fracture on steel tube above and below the joint panel zone. It was found that both axial forces and beam to column linear stiffness ratio had impacts on joint capacity and ductility behavior of the specimens. However, addressed beam-column joints of substandard RC frames with weak columns, poor anchorage of longitudinal beam bars and insufficient transverse reinforcement. The behavior of exterior beam column joint is different than the corner beam column joint.

2.2 Subramani, T., & Piruntha, M. (2018).

Fly Ash based geopolymer concrete is critical to study the fulfillment of a new material in various packages for its use in production of structures and additionally the eco

pleasant concrete. For implement this recent material distribution of longitudinal and lateral metal, tie spacing, and the extent of axial load. Model created by ANSYS with 9-foot long columns. Loading will be increased gradually 10KN maximum deflection at 0.051mm at 50KN. The specimens have been subjected to an axial load underperforming FE analysis of RCC column by using ANSYS software. The result shows the appropriate way of using the scientific technique to geopolymer concrete columns subjected to mixed axial load and biaxial bending.

2.3 Rajan, C. S., Gopinath, G., Devaraju, A., & Anbarasan, B. (2020).

This paper investigates the behavior of Doubled skinned (DSCFT) composite hollow columns with steel tubes compressed under concentric axial loads. The DSCFT member is a new type of composite construction, which consists of two concentric steel tubes with geopolymer concrete sandwiched between them. Thus, DSCFT columns have a series of advantages, such as high strength, high bending stiffness, good seismic and fire performance, and also having favorable construction ability. The finite element analysis of the DSCFT circular column is conducted to validate the finite element model. The results obtained from the finite element investigation are compared with the strength values predicted using existing formulations in the analytical investigation. A good correlation was found between the values obtained.

2.4 Defalla, R., El, A., Rahman, A., Ahmad, M., & Khafaga, M. A. (2019).

In this paper, a combination of both fly ash and GGBS were used to make geopolymer concrete along with sodium hydroxide and sodium silicate solutions. This paper focuses on the study of reinforced geopolymer concrete columns. The objectives of this paper are to experimentally study the ultimate axial load and shorting of geopolymer columns with varying strengths under axial loading. The experimental study included testing of two geopolymer concrete short columns and two conventional concrete short columns. In addition, the behaviors of columns of geopolymer concrete were studied. The behaviors include toughness, stiffness and ductility. The effects of different variables were considered and experimentally investigated in the current study. The tested four columns reflect these variables which are the effect of the grade of parent concrete that the geopolymer materials were made of and the quality of the concrete of the parent concrete mix. Each column was loaded to failure and some topics were covered through the analysis of the test results. All columns that possessed slag with replacement ratio of fly ash showed upper ultimate carrying

capacities, lower stiffness values, and lower toughness values when compared with the conventional columns. Increasing the grade of the parent concrete of the geopolymer concrete decreases each of the reduction of the stiffness and toughness of the tested columns.

2.5. Maranan, G. B. (2016).

In Australia, the environments are severe to use steel as reinforcement to concrete structures from the viewpoint of corrosion damage. With the limited resources of the state and the federal governments to maintain existing infrastructures, a new approach for construction of more durable infrastructures is required. As a result, glass fiber reinforced polymer (GFRP) bars have gained considerable worldwide interest for use as internal reinforcement to concrete structures that operate in highly aggressive environments. At the same time, the use of geopolymer cement as an alternative to ordinary portland cement (OPC) is currently attracting increasingly widespread attention because its manufacture does not directly create CO₂ emissions. However, there is inadequate scientific research undertaken to substantiate the benefit of the combined use of these materials in actual infrastructure, which has been the key motivation for this research. Therefore, this study investigated the suitability and structural.

III. METHODOLOGY

3.1 RESEARCH METHODOLOGY

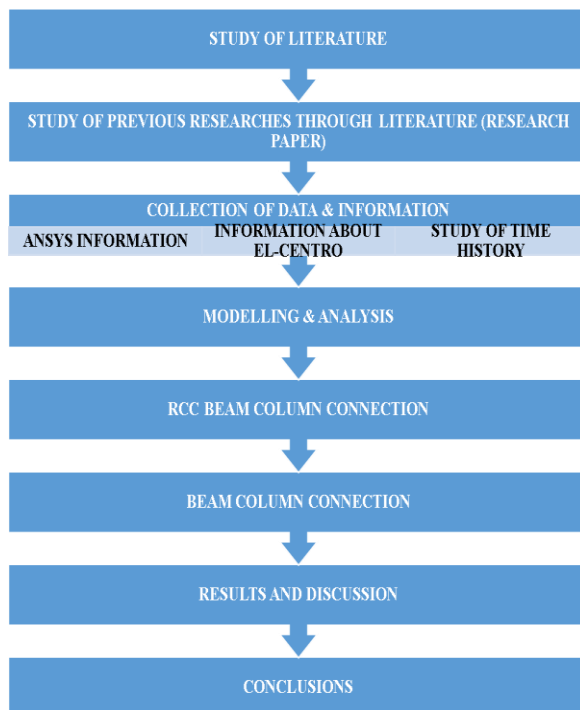

Fig 1: Flowchart

3.2 Time history analysis

Dynamic analysis using the time history analysis calculates the building responses at discrete time steps using discredited record of synthetic time history as base motion. If three or more-time history analyses are performed, only the maximum responses of the parameter of interest are selected. Time history analysis is the study of the dynamic response of the structure at every addition of time, when its base is exposed to a particular ground motion. Static techniques are applicable when higher mode effects are not important. This is for the most part valid for short, regular structures. Thus, for tall structures, structures with torsional asymmetries, or no orthogonal frameworks, a dynamic method is needed.

3.3 EL CENTRO EARTHQUAKE DATA USED

It was the first major earthquake that has been recorded by a strong-motion seismograph located next to a fault rupture. The earthquake was characterized as a typical moderate-sized destructive event with a complex energy release signature. It was the strongest recorded earthquake to hit the Imperial Valley, and caused widespread damage.

3.4 SOFTWARE PROPOSED

STAAD PRO(BUILDING)

ANSYS 16(FOR JOINT)

3.5 PROBLEM STATEMENT

A G+9 RCC Commercial building is considered.

Plan dimensions: 12 m x 12 m

Location considered: Zone-III

Soil Type considered: Hard Strata.

General Data of Building:

- Grade of concrete: M 25
- Grade of steel considered: Fe 250, Fe 500
- Live load on roof: 2 KN/m² (Nil for earthquake)
- Live load on floors: 4 KN/m²
- Roof finish: 1.0 KN/m²
- Floor finish: 1.0 KN/m²
- Brick wall in longitudinal direction: 240 mm thick
- Brick wall in transverse direction: 140 mm thick
- Beam in longitudinal direction: 230X350 mm
- Beam in transverse direction: 230X350 mm
- Column size: 300X750 mm
- Density of concrete: 25 KN/m³
- Density of brick wall including plaster: 20 KN/m³
- Plinth beam (PB1): 350X270 mm
- Plinth beam (PB2): 270X300 mm

➤ Introduction:

In order to identify the critical beam we have considered a G+7 RCC Commercial building for analysis and design purpose in STAAD pro software which is analyzed for 1.5(DL+LL) load combination and the beam with maximum bending moment is identified for considered building the details of the building considered are as follows:



Fig 2: G + 9 Frame Storied Building And Having Loads Can Apply On Beams And Columns

MODELLING IN STADD PRO

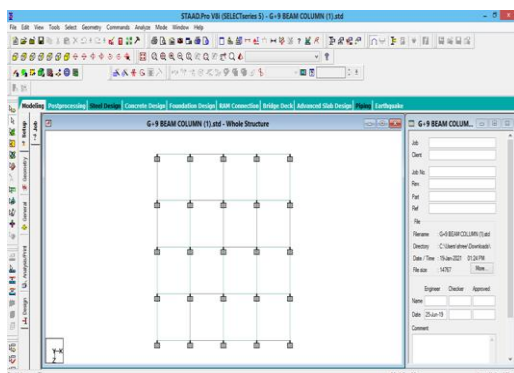

Fig 3: Plan View

IV. MODELLING IN STADD PRO

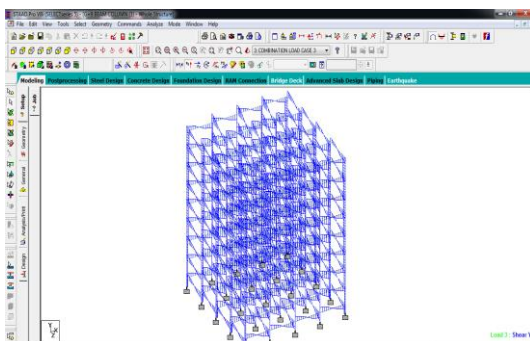

Fig 4: Shear Force Of Beams In STAAD Pro

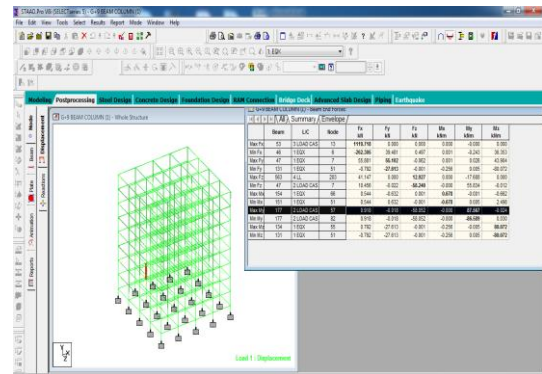

Fig 5: Reactions

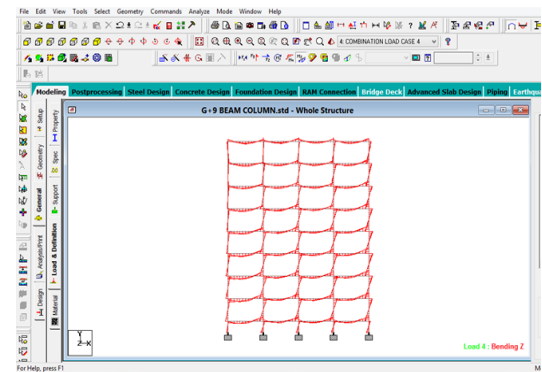

Fig 6: Bending Moment Of Beams In STAAD Pro

V. THEORETICAL CONTENT

4.1 Material modeling

The definition of the proposed numerical model was made by using finite elements available in the ANSYS code default library. SOLID186 is a higher order 3-D 20-node solid element that exhibits quadratic displacement behavior. The element is defined by 20 nodes having three degrees of freedom per node: translations in the nodal x, y, and z directions. The element supports plasticity, hyperelasticity, creep, stress stiffening, large deflection, and large strain capabilities. It also has mixed formulation capability for simulating deformations of nearly incompressible elastoplastic materials, and fully incompressible hyperelastic materials. The geometrical representation of is show in SOLID186 fig 22.

This SOLID186 3-D 20-node homogenous/layered structural solid were adopted to discretize the concrete slab, which are also able to simulate cracking behavior of the concrete under tension (in three orthogonal directions) and crushing in compression, to evaluate the material non-linearity and also to enable the inclusion of reinforcement (reinforcement bars scattered in the concrete region). The element SHELL43 is defined by four nodes having six degrees of freedom at each node. The deformation shapes are linear in both in-plane directions. The element allows for plasticity,

creep, stress stiffening, large deflections, and large strain capabilities. The representation of the steel section was made by the SHELL 43 elements, which allow for the consideration of non-linearity of the material and show linear deformation on the plane in which it is present. The modeling of the shear connectors was done by the BEAM 189 elements, which allow for the configuration of the cross section, enable consideration of the non-linearity of the material and include bending stresses as shown in fig 3.5. CONTA174 is used to represent contact and sliding between 3-D "target" surfaces (TARGE170) and a deformable surface, defined by this element. The element is applicable to 3-D structural and coupled field contact analyses. The geometrical representation of CONTA174 is show in fig 3.2. Contact pairs couple general axisymmetric elements with standard 3-D elements. A node-to-surface contact element represents contact between two surfaces by specifying one surface as a group of nodes. The geometrical representation of is show in TARGET 170 fig 19.

The TARGET 170 and CONTA 174 elements were used to represent the contact slab-beam interface. These elements are able to simulate the existence of pressure between them when there is contact, and separation between them when there is not. The two material contacts also take into account friction and cohesion between the parties.

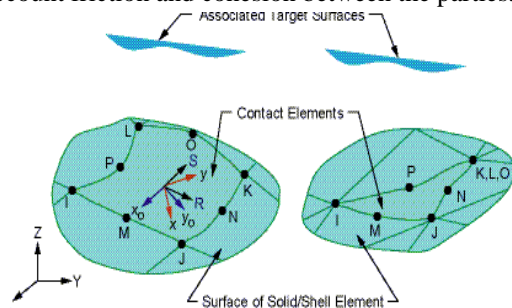

Fig. 7 CONTA 174

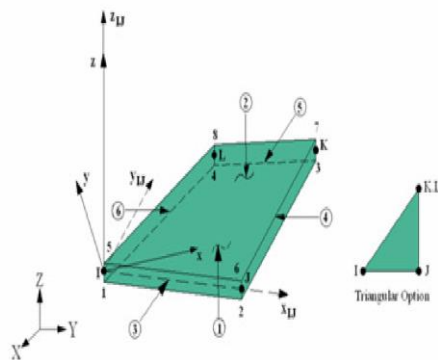

Fig 8: Shell 43

4.2 Material properties

Sr.No.	Material	Property	Value
1	Structural steel	Yield stress f_{sy} (MPa)	265
		Ultimate strength f_{su} (MPa)	410
		Young's modulus E_s (MPa)	205×10^3
		Poisson's ratio μ	0.3
		Ultimate tensile strain e_t	0.25
2	Reinforcing bar	Yield stress f_{sy} (MPa)	250
		Ultimate strength f_{su} (MPa)	350
		Young's modulus E_s (MPa)	200×10^3
		Poisson's ratio μ	0.3
		Ultimate tensile strain e_t	0.25
3	Concrete	Compressive strength f_{sc} (MPa)	42.5
		Tensile strength f_{sy} (MPa)	3.553
		Young's modulus E_c (MPa)	32920
		Poisson's ratio μ	0.15
		Ultimate compressive strain e_s	0.045
4	Duplex steel	Yield stress f_{sy} (MPa)	435
		Tensile strength f_{su} (MPa)	530
		Young's modulus E_s (MPa)	200×10^3
		Poisson's ratio μ	0.31
		density	7.8

4.4 Staad Pro

STAAD or (STAAD Pro) is a structural analysis and design software tool that was created in 1997 by Research Engineers International. Bentley Systems acquired Research Engineers International in late 2005. STAAD Pro is a structural analysis and design software application that is extensively used across the globe. It complies with over 90 international design regulations for steel, concrete, wood, and aluminium. It may use a variety of analytical techniques, ranging from classical static analysis to more contemporary techniques such as p-delta analysis, geometric non-linear analysis, pushover analysis (Static-Non Linear Analysis), or buckling analysis. Additionally, it may make use of a variety of dynamic analytic techniques, ranging from time history analysis to response spectrum analysis. The response spectrum analysis capability works with both user-defined and a variety of international code-defined spectra. Additionally, STAAD Pro is compatible with products such as RAM Connection,

Auto PIPE, and SACS, as well as a variety of other engineering design and analysis software, which facilitates cooperation across the many disciplines involved in a project. STAAD may be used to analyse and design a wide variety of structural structures, ranging from plants and buildings to towers, tunnels, metro stations, and water/wastewater treatment facilities.

VI. MOEDLLING

4.4 ANSYS model: -

Details for ANSYS Models for Precast and RCC

Column Size – 300 x 750 mm

Reinforcement for Column – 12 \varnothing – 16No

Beam Size – 230 x 450 mm

Reinforcement for Beam – Top – 12 \varnothing -2, Bottom- 12 \varnothing -2,

Shear – 10 \varnothing @120 C/C

Total Maximum Load – 1824 KN

- RCC Model

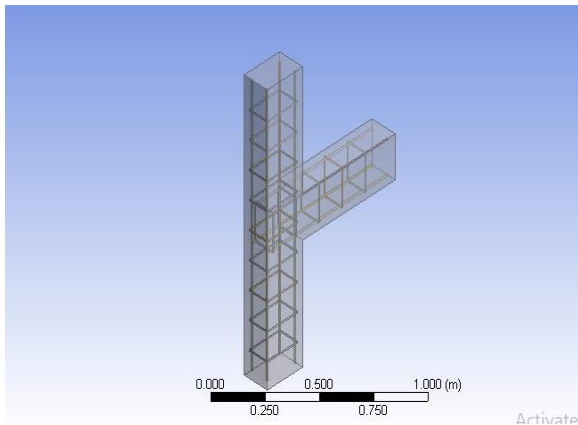

Fig 9: No wrapping model

- Geopolymer Specimen 1

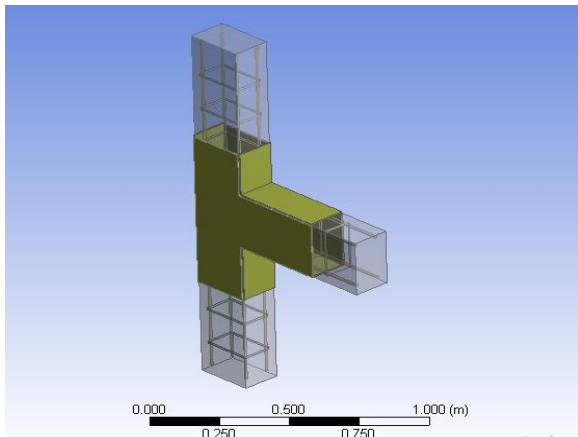

Fig 10: Total wrapping model

- Geopolymer Specimen 2

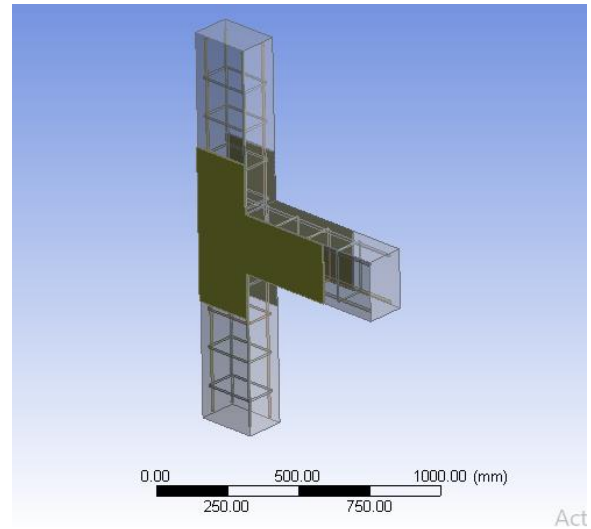

Fig 11: Side wrapping model

- Geopolymer Specimen 3

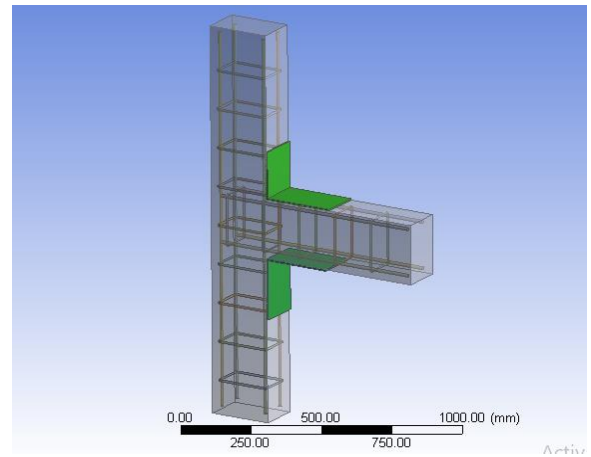
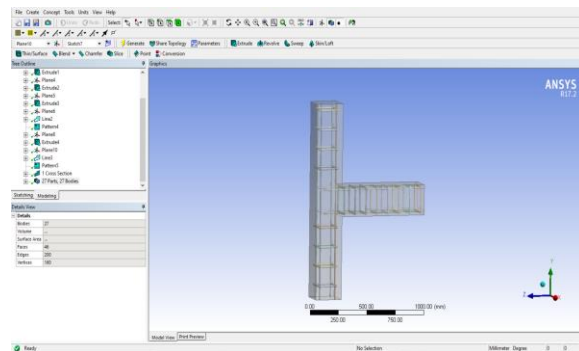

Fig 12: Top-bottom wrapping model

Analysis of Beam-Column joint by using ANSYS Software:-

Modeling of beam column joints in ANSYS Software For T-Shape:-



**Results of Casted Beam-Column Joints
For T shape**

Specimens	Load in KN		Deflection in mm
	Column	Beam	
1	135	23	3.2
2	110	17	2.8
3	120	20	2.9

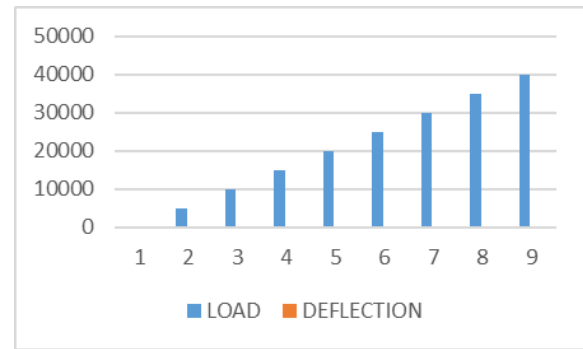

As we can see in the graph, deflection is increasing as per loads are increasing. Also stress and strain and increasing when loads are increasing.

VII. RESULT AND DISCUSSION

Comparison of Experimental and ANSYS model

- For T shape

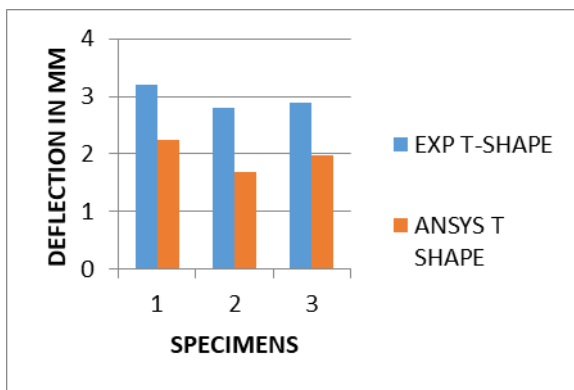

Analysis of Geo polymer Specimens

For T Shape: - Geo polymer Specimen 1 (GS1)

LOAD	DEFLECTION	STRESS	STRAIN
0	0	0	0
5000	1.2002	68.617	0.002053
10000	1.1786	99.863	0.002441
15000	2.1618	131.5	0.002829
20000	3.1504	163.137	0.003217
25000	4.139	194.774	0.003606
30000	5.1276	226.411	0.003994
35000	6.1162	258.048	0.004382
40000	7.1048	289.685	0.00477

LOAD	DEFLECTION	STRESS	STRAIN
0	0	0	0
5000	4.39116	186.208	0.002361
10000	5.32059	754.676	0.002807
15000	6.25002	758.793	0.003254
20000	7.17945	762.9215	0.0037
25000	8.10888	767.05	0.004146
30000	9.03831	771.1785	0.004593
35000	9.96774	775.307	0.005039
40000	10.89717	779.4355	0.005485

**load vs Deflection For T Shape with Geo polymer
GS1**

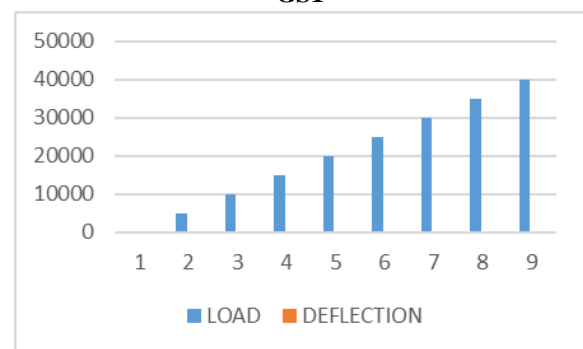

As we can see in the graph, deflection is increasing as per loads are increasing. Also stress and strain and increasing when loads are increasing.

Load vs Deflection For T Shape without Geo polymer

Analysis of Geo polymer Specimens

For T Shape: - Geo polymer Specimen 2 (GS2)

LOAD	DEFLECTION	STRESS	STRAIN
0	0	0	0
5000	2.036	154.470	0.001966
10000	19.231	180.560	0.001968
15000	19.233	206.650	0.001969
20000	20.235	232.740	0.002274
25000	21.237	258.830	0.002761
30000	22.239	284.920	0.003248
35000	23.241	311.010	0.003735
40000	24.243	337.100	0.004222

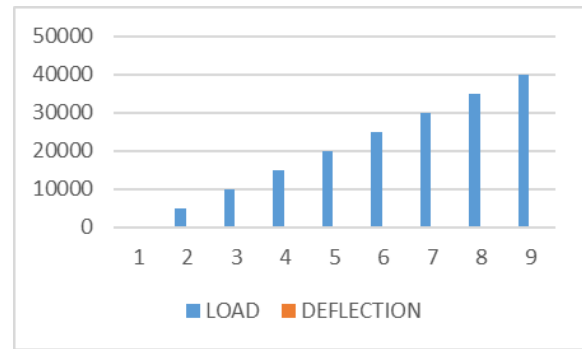

load vs Deflection For T Shape with Geo polymer C3

As we can see in the graph, deflection is increasing as per loads are increasing. Also stress and strain and increasing when loads are increasing.

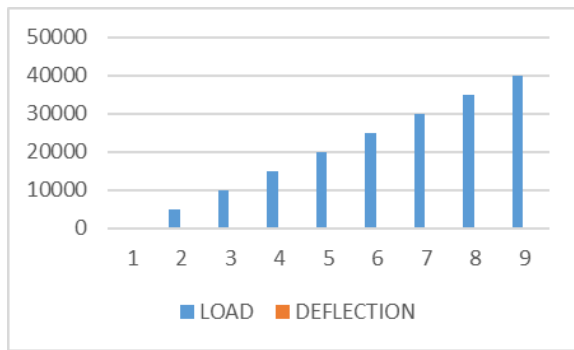

load vs Deflection For T Shape with Geo polymer GS2

As we can see in the graph, deflection is increasing as per loads are increasing. Also stress and strain and increasing when loads are increasing.

LOAD	DEFLECTION	STRESS	STRAIN
0	0		
5000	3.8184	161.920	0.00082
10000	4.6266	656.240	0.00353
15000	5.4348	659.820	0.00354
20000	6.2430	663.410	0.00356
25000	7.0512	667.000	0.00357
30000	7.8594	670.590	0.00358
35000	8.6676	674.180	0.00359
40000	9.4758	677.770	0.00360

VIII. CONCLUSION

- The goal of the comparison of FE analysis results with the experimental test results is ensure that the present finite-element model and analysis are capable of predicting the response of the beam-column joints.
- Comparison between the load-Stress results obtained from finite element analysis for control and Geo polymer specimens shows that the Stress has significantly increased for the Geo polymer specimen. The Stress of GFRP specimens of T shape and L shape- RG1, RG2 and RG3 are 63.15%, 17.04%, 13.04% Less than the Non retrofitted specimen.
- The different configurations of GFRP considered or the specimens were by attaching to the top, bottom and lateral sides of beams. The results show that the stress, Strains are reduced as compared to non Geo polymer specimen.
- As the stress decreased the load carrying capacity and strength increases by using GFRP as compared to non-Geo polymer specimen.
- Cracks are developed at the joint due to shear failure. It shows the cracking pattern in beam column joint.

REFERENCES

- [1] Dineshkumar, K. L. G. (2021). *Exterior RC Beam-Column Joints Retrofitted with CFRP Sheets and their Seismic Behavior*. 7(04), 151–155.
- [2] June, M. (2017). *Analytical Study Of T Beam Column Joint Using FEM Software*. 6(3).
- [3] Subramani, T., & Piruntha, M. (2018). *Behaviour of CRP-Geopolymer Concrete Columns under Axial Loading using ANSYS*. 7, 203–206.
- [4] Rajan, C. S., Gopinath, G., Devaraju, A., & Anbarasan, B. (2020). Non-linear analysis of double skinned composite hollow columns using geopolymer concrete. *Materials*

- Today: *Proceedings*, 39, 662–668.
<https://doi.org/10.1016/j.matpr.2020.09.186>
- [5] Defalla, R., El, A., Rahman, A., Ahmad, M., & Khafaga, M. A. (2019). *Analysis of Geopolymer Concrete Columns at Normal and High Strength*. 11595–11604.
<https://doi.org/10.15680/IJRSET.2019.0812019>
- [6] Maranan, G. B. (2016). Structural Behaviour of Geopolymer Concrete Beams and Columns Reinforced with Glass Fibre Reinforced Polymer Bars. *Ph.D Dissertation, January*, 21–22.
- [7] Abdelwahed, B. (2020). Nonlinear numerical simulation for reinforced concrete elements with explicit time integration procedure. *Case Studies in Construction Materials*, 12, e00344.
<https://doi.org/10.1016/j.cscm.2020.e00344>
- [8] Raj, S. D., Ganesan, N., Abraham, R., & Raju, A. (2016). Behavior of geopolymer and conventional concrete beam column joints under reverse cyclic loading. *Advances in Concrete Construction*, 4(3), 161–172.
<https://doi.org/10.12989/acc.2016.4.3.161>