

# Fabrication of Hand Operated Clutch And Car Parking For 5th Wheel system using Legless persons

JithendraKumar S<sup>1</sup>, Manoj Kumar<sup>2</sup>, Navin T.P.V<sup>3</sup>, Raghul A<sup>4</sup>, Mr.Saravanan P<sup>5</sup>

<sup>1,2</sup> Dept of Mechanical Engineering

<sup>1,2</sup> K.S.RCollegeofEngineering,Tiruchengode,Namakkal(district)

-637215.Tamilnadu

**Abstract-** In earlier methods of parking, the time taken is 2 minutes; the driver needs to be more alert while parking in order to avoid hitting of the car during the reverse motion. Therefore, to avoid these inconveniences, a concept of fifth wheel parking is made, where the total time will be 50 to 60 seconds. This parking can be done using an additional wheel fifth wheel. A screw is used to control fifth wheel to land and lift. DC motor enables the forward and reverse motion for the screw. It also helps to know malfunctions during landing or lifting of the wheel. This concept is mainly used for four-wheeler vehicles. This setup makes the vehicle to turn parallel in a significant angle with reference to the front axle within a short period. The model enables the driver to park the vehicle between two vehicles, where the space is limited.

**Keywords-** Parking System, Screw, Control Unit, additional wheel, DC motors.

## I. INTRODUCTION

Parallel parking is a method of parking a vehicle in-line with other parked vehicles. Parallel parking requires initially driving slightly past the parking space, parallel to the parked vehicle in front of that space, keeping a safe distance, and then followed by reversing into that space. Subsequent position adjustment may require the use of forward and reverse gears. Parallel parking is considered to be one of the hardest skills for new drivers to learn. Parallel parking enables the driver to park a vehicle in a smaller space than would be true of forward parking. Driving forward into a parking space on the side of a road is typically not possible unless two successive parking spaces are empty. Reversing into the spot via the parallel parking technique allows one to take advantage of a single empty space not much longer than the car in order to complete the parking within three wheel-turns the parking space would generally need to be about one and a half car length long.

## II. PROBLEM STATEMENT

In automobiles, parking system is complicated and time taking to park the vehicle, needs to be more alert while

parking in order to avoid hitting of the car during the reverse motion. Therefore to avoid, a concept of fifth wheel parking is made and also for handicap persons.

## III. STUDY OF AVAILABLE MECHANISMS

**By using rack and pinion** parking can be done using an additional wheel (an Auxiliary Drive Wheel) most probably this will be a Stepony wheel. Initially, when the driver finds a slot for parking, he pushes the button and the DC motor actuates the movement of rack and pinion. Rack and pinion will applied force on the one side of triangular hub and due to the pivot point the triangular hub move in angular moment and other side of triangle will lift auxiliary wheel. This will land the auxiliary wheel on the road and slightly lifts the rear side of the vehicle. A rack and pinion and triangular hub set up is used to control an Auxiliary drive wheel to land and lift. The model enables the driver to park the vehicle between two vehicles, where the space is limited.

**By using pneumatic and hydraulic cylinder.** The project is consists of steering rod, rack and pinion gears, pneumatic cylinder, solenoid valve fifth wheel and its supporting wheels. Vehicle steering is controlled by rack and pinion arrangement. Initially, when the driver finds a slot for parking, he can place the front axle of the car in any angle. When the driver push the button for the reversing, the solenoid valve actuates the pneumatic cylinder, this will land the fifth wheel on the road and slightly lifts the rear side of the vehicle. The fifth wheel is moved forward/reverse using a DC motor. After parking the vehicle in correct alignment, the fifth wheel is lifted when the cylinder retracts. Simultaneously, the driver gets the status of the process in the display kept in the dashboard of the car. This will helps to diagnose the problem during malfunction consists of three wheels. The center wheel runs with help of motor. This is carried out by us made an impressing task in four wheelers. It is very useful for parking four wheelers, because they need not take any risk for park the vehicle and quick operation. This project will reduce the cost involved in the concern. Project has been designed to perform the entire requirement task at the shortest time available.

**IV. 4. REASONS BEHIND PARKING ACCIDENTS**

**Driver characteristics** age, gender, race, and alcohol or drug use, this are the main reasons for accident. Age matter while driving the vehicle while getting proper guessing for parking. Age group of people between 18 to 50 can drive vehicle properly but the age group of 50 to70 unable to drive vehicle safely because of lack of decision taking ability. The outcomes demonstrated that driver's significantly affected the likelihood of parking area crashes. Female drivers were around 23 percent bound to be associated with these accidents than male drivers. Utilization of liquor and drugs drivers' basic leadership capacity and loss of vision. Likewise it decreases readiness and concentration that may result in accidents. Strangely, this factor was observed to be increases upto the 95 %.

**Environment condition**, the impact of lighting conditions, vision impediment, and climate conditions were discovered noteworthy for parking area crashes. Crash affinity was 20% percent lower amid first light and sunset hours than amid daytime. The likelihood of an accident at the point when vision is hindered by trees was observed to be about occasions higher than when vision is unhampered. It was intriguing to find that the chances proportion of accident inclination at parking areas amid overcast, stormy, or foggy climate was lower than in clear/great climate. Maybe individuals drive all the more carefully in severe climate. This causes a lots of accidents.

**V. COMPONENTSTOBEUSED**

1. Clutch pedal
2. Spring
3. Brake pedal
4. Steering
5. Rack and pinion
6. D.C motor
7. Screw rod
8. Battery

**BLOCK DIAGRAM**

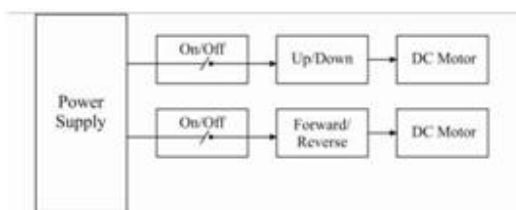

**VI. WOKING OF MECHANISM**

As from the block diagram it is easy to understand the actual working of the fifth wheel car parking mechanism. Battery is a device consisting of one or more electrochemical cells with external connection provided to power to dc motor and other appliances. It is main source

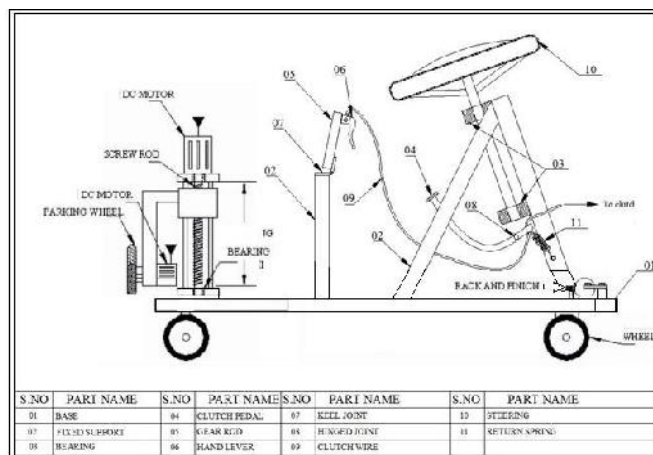

**Fig.1 Working layout**

of the power in the project having 12 volt capacity. Remote controller is contain the switches to control the power circuits. It also control the motor revolution. In the project control unit has two switches and each control the single DC motor motion. DC motor is an important devices which helps to move the project. Two DC motor are used in the project. Both motors having 100 rpm revolving capacity but as the project required the less rpm than the 15 to 20 rpm. Hence special type of gear arrangement is used with motor and it reduce its rpm upto 20 rpm. Screw, one DC motor is placed vertically at the end of screw and shaft of the motor is connected with the screw such that when the motor revolve screw starts to revolve. At the same time this screw is revolve in the nut which is connected to the vertical supporter. Supporter connected with the frame of vehicle model. When the screw rotates it lift the whole frame of model like screw jack mechanism. First motor lift the frame up to some height as 40mm and the stops. Now second motor is operated with the control unit. Second DC motor is placed at the other end of the screw at the perfectly perpendicular direction. At the shaft of the second DC motor fifth wheel is fixed. Fifth wheel of also has the perpendicular direction of motion with respect to the other four wheels. Fifth wheel has the back and forward motion with the help of the motor. As the mechanism is placed at the rear end, it oscillate the rear end of the frame. When the displacement of the rear end is done then again first motor revolve in anticlockwise direction and it lift the fifth wheel up to specific distance height and frame is placed on the other two wheels. In this way the operation is performed.

## VII. LITERATURE REVIEW

Priyadarshini R, et al.[1] done the work on parallel parking of car using fifth wheel. According to his study, Parallel parking is the method of park the vehicle parallel in between the two-vehicle keeping the safe distance. They developed a system by introducing a fifth wheel at the rear side of the vehicle. The pneumatic system is used as a jack to lower the wheel and lift the vehicle from the rear side. The prime mover is used to provide a power to the fifth wheel and for forward and reversed rotation is also done by motor. Firstly, the driver places the vehicle at an angle from the front. As soon as the driver push the button the wheel is goes downwards and vehicle lifted up from rear side. The prime mover gives the rotation to the wheel as per the requirement (Forward or Reversed) and the vehicle park in between the vehicles. For this system they implement a digital display to indicate the status of the fifth wheel.

K.R.Prabhu, S. Gokulraj, L. Jeeva, M. Leon Richardson, R. Manikandan, done the work on fabrication of parallel car parking, using 5th wheel according to his study ,In earlier methods of parking, the time taken is 2 minutes (approx), the driver needs to be more alert while parking in order to avoid hitting of the car during the reverse motion. Therefore, to avoid these inconveniences, a concept of parallel parking is made, where the total time will be 50 to 60 seconds. This parking can be done using an additional wheel, A pneumatic cylinder and solenoid valve set up is used to control fifth wheel to land and lift. A DC motor enables the forward and reverse motion for the fifth wheel. A digital display is used to indicate the status of the wheel for the driver reference. It also helps to know malfunctions during landing or lifting of the wheel. This concept is mainly used for four-wheeler vehicles. This setup makes the vehicle to turn parallel in a significant angle with reference to the front axle within a short period. The model enables the driver to park the vehicle between two vehicles, where the space is limited. This is carried out by us made an impressive task in four wheelers. It is very useful for parking four wheelers, because they need not take any risk for park the vehicle and quick operation. This project will reduce the cost involved in the concern. Project has been designed to perform the entire requirement task at the shortesttime available. [1]

Priyadharshini R, Indumathi T, Pavithra M, Rini priya T, Sahaana V, done the work on Parallel Parking of Carfifth wheel according to his study , Parallel parking is a method of parking a vehicle in-line with other parked vehicles. Parallel parking requires initially driving slightly past the parking space, parallel to the parked vehicle in front of that space, (hence the term 'Parallel Parking'), keeping a safe distance,

and then followed by reversing into that space. Subsequent position adjustment may require the use of forward and reverse considered to be one of the hardest skills for new drivers to learn. Parallel parking enables the driver to park a vehicle in a smaller space than would be true of forward parking. Driving forward into a parking space on the side of a road is typically not possible unless two successive parking spaces are empty. Reversing into the spot via the parallel parking technique allows one to take advantage of a single empty space not much longer than the car (in order to complete the parking within three wheel- turns the parking space would generally need to be about one and a half car-length long). The is carried out by us made an impressive task in four wheelers. It is very useful for parking fourwheelers, because they need not take any risk for park the vehicle and quick operation. This project will reduce the requirement of time & effort task during parking of vehicle.[2]

A. Albagul, K. Alsharef, M. Saad, Y. Abujeela, done the work on, Design and Fabrication of an Automated Multi- level Car Parking System, according to his study, In this paper, the basic multi-level car parking system with three floors is considered to show the use of control systems in parking systems. The control system will play a major role in organizing the entry to and exit from the parking lots. It also presents the design of multi-level parking lots which occupies less need on the ground and contains the large number of cars. In the modern world, where parking-space has become a very big problem, it has become very important to avoid the wastage of space in modern big Automatic multi-level car parking system helps to minimize the car parking area companies and apartments. The parking lots have an elevator to carry cars to different floors according to the vacancies. The elevator is controlled by a programmable logic controller (PLC) along with the help of some sensors. The multi-level car parking system had successfully been designed and developed. The control strategy for the traffic flow to the multi-level car parking system was carried out using the PLC. The PLC with the help of some sensors checks the availability of the vacant place on each floor. It can be noticed that the control system for the multi-level car parking system has achieved the anticipated performance to regulate the entry and exit of the car to/from several floors accurately. The movement of the elevator between the floors was continuous and smooth as requested. The number of entering and existing car from all the three floors was controlled as per the signals from the sensors on each floor at the entry and exit point. The entry and exist phases of the cars depends on the availability of the elevator and the time required for exist. The preference for the entry will be for the car that is present at the stopping in front of an elevator at the ground floor. Meanwhile, the preference for

exist from other floors will depend firstly on the space and secondly on the time demanded for exist. [3]

Trupti Y. Nirwan, Akash S. Waghmare, Gaurav R. Rahate, Kartik Bhujade, Asaraf Ali Saiyyad, Adarsh Shahu, Prof. A.D. Anjekar, done the work on, introduction to vertical multistage car parking system according to his study, In metropolitan cities, vehicle parking has become a major concern in all busy areas and a good traffic system needs a good parking system. Different types of vehicle parking are applied worldwide namely Multi-level Automated Car Parking, Automated Car Parking System, volkswagen Car Parking, vertical car parking etc. Parallel parking is challenge for all drivers say amateurs or the experts. An multistage car parking system is a solution to this ordeal. This paper explains in detail a simple and precise multistage car-parking introduction, advantages, characteristics, etc. This paper give the information to develop a reduced working model of a car parking system for parking 6 to 24 cars within a parking area of 32.17 m<sup>2</sup>. The chain and sprocket mechanism is used for driving the parking platform and a one fourth hp brake motor shall be implemented for powering the system and indexing the platform .The platform is fabricated to suit. Vertical Car Parking model has been designed; all the parts in it were manufactured and assembled and tested successfully. Analysis of the model has been done and developed with the scaling of 1:9 for life size model Such as SUV's like Fortuner. As the life cycle model involves proper design and advanced methods are to be used to meet the requirements of the customer. Quick Automated Parking and retrieval of vehicles. Up to 12 cars can be easily and safely parked. Surface space required equivalent to just 2 surface car parking spaces. Most suitable for Staff or dedicated user parking. Engineered to ensure Driver safety by use of an electronic Safety zone. Low maintenance levels required by the system. [4]

### VIII. ADVANTAGES

- This made the parking easy.
- Less time required to park the car.
- It is very cheap as components like sensors, ECU, hydraulic pump etc are not used.
- Construction of mechanism is easy.

### IX. SCOPE FOR FUTURE

1. As per recent condition the people will get problem for the parking space because the in cities, Restaurants, Cinema halls where people regularly use to visit they required the space to park the vehicle between to two vehicle in less space. This mechanism overcome this type of problem.

2. Time required for parking the vehicle between the two vehicle is more. And drive should have conscious otherwise the vehicle get smashed with the other one. Where the fifth wheel car parking mechanism is time efficient and safe.
3. This parking mechanism is cheap in cost because it do not required any sensors and costly ECU. It is just simple mechanism.

### X. CONCLUSION

This project report on the Fabrication Of Hand Operated Clutch and Car Parking For 5th Wheel System Using Legless Persons is to improve the parking system with less cost. It define the time saving while car parking in the crowded area. It also introduces a method to eliminate the complex mechanism which is used in recent cars with number of sensors and complicated microcontrollers.

### REFERENCES

- [1] K.R.Prabhu, S. Gokulraj, L. Jeeva, M. Leon Richardson, R. Manikandan, fabrication of parallel car parking, using 5th wheel, EPH - International Journal of Science and Engineering ISSN: 2454 – 2016. Special Issue |Vol-1 |Issue- 1 |Recent Advancements in Mechanical Engineering - RAME'18, pp.279-285.
- [2] Priyadharshini R, Indumathi T, Pavithra M, Rini priya T, Sahaana V, Parallel Parking of Car using fifth wheel, International Journal of Innovative and Emerging Research in Engineering Volume 4, Special Issue 1,NCIAR, 2017,pp.105-107.
- [3] Albagul, K. Alsharif, M. Saad, Y. Abujeela, Design and Fabrication of an Automated Multi- level CarParking System, Manufacturing Engineering, Automatic Control and Robotics, ISBN: 978-960-474- 371-1,pp.173-178.
- [4] Trupti Y. Nirwan ,Akash S. Waghmare, Gaurav R. Rahate, Kartik Bhujade, Asaraf Ali Saiyyad, Adarsh Shahu6, Prof. A.D. Anjekar, introduction to vertical multistage car parking system,International Research Journal of Engineering and Technology (IRJET) e- ISSN: 2395 -0056 Volume: 03 Issue: 04 |Apr- 2016,pp.1492-1494.
- [5] Atul A Dhawale, Rohitkumar R Gupta, Shubham A Gawande, Yogesh D Bate, Prof. V. S. Nikam, Design and Fabrication Automatic Pneumatic Inbuilt Jack System by using Fifth Wheel Parking System,IJSRD - International Journal for Scientific Research & Development|Vol. 5, Issue 01, 2017 |Issn (Online): 2321-0613.Pp.67-68.
- [6] Sathish Kumar K, Mohammed Shabirullah, Design And Fabrication Of “360 Degree Car Parking”, International

Journal of Pure and Applied Mathematics Volume 116  
No. 16 2017,pp.171-175.