

Harmonic Elimination In Multilevel Inverters Using Cuckoos Search Algorithm

S.Vijaya Samundeeswari¹, I. Gerald Christopher Raj²

^{1,2}Dept of Electrical and Electronics Engineering

¹Christian College of Engg. & Tech, Dindigul, India.

²PSNA College of Engg. & Tech, Dindigul, India.

Abstract- A new approach for minimization of total harmonic distortion (THD) of a multilevel flying capacitor inverter (MFCI) based on the selective harmonic elimination named stochastic THD (STHD) strategy is proposed. In the STHD strategy, the step voltage levels of multilevel inverter are considered to be varying due to unbalanced capacitor voltages. This paper improves modeling of harmonic elimination. In the proposed strategy, the switching angle variations and unbalancing of flying capacitor voltages are evaluated by formulation of $2m+1$ is combined with new modified cuckoo search algorithm and a self-adaptive mutation tactic for the establishment of new robust algorithm for minimization of the THD and the best switching angles pattern in low switching frequency without measuring current and capacitor voltages.

Keywords- flying capacitor inverter, harmonic elimination, multilevel inverter, total harmonic distortion (THD).

I. INTRODUCTION

Now a day’s many industrial applications have begun to require high power. Some applications in the industries however require medium or low power for their operation. Using a high power source for all industrial loads may prove beneficial to some motors requiring high power, while it may damage the other loads. Some medium voltage motor drives and utility applications require medium voltage. The multilevel inverter has been introduced since 1975 as alternative in high power and medium voltage situations. The Multi level inverter is like an inverter and it is used for industrial applications as alternative in high power and medium voltage situations.

The need of multilevel converter is to give a high output power from medium voltage source. Sources like batteries, super capacitors, solar panel are medium voltage source. The multi level inverter consists of several switches. In the multi level inverter the arrangement switches’ angles are very important.

A power inverter is an electronic device that changes direct current (DC) to alternating current (AC). The input voltage, output voltage and frequency, and overall power

handling depend on the design of the circuitry. The inverter does not produce any power, the power is provided by the DC source. A power inverter can be entirely electronic circuitry. Static inverters do not use moving parts in the conversion process

The THD minimization problem under uncertainty is commonly a large-scale, nonlinear, and mixed integer

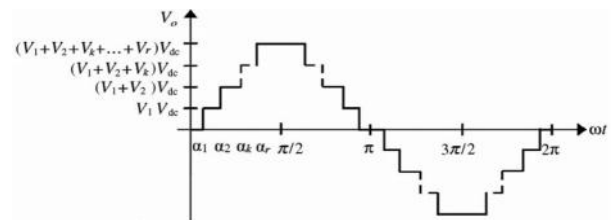

Fig 1 Switching angles for an MFCI

combinatorial problem. Therefore, in this study, modified cuckoo search algorithm (MCSA) is proposed to solve the CTHD and STHD minimization problems. The cuckoo search algorithm (CSA) is a new optimization algorithm that is based on the exceptional lifestyle of cuckoo birds and their characteristics in the egg laying and breeding. The performance of the original CSA depends on its parameters, such as maximum distance from their habitat for laying and the migrate factors. These dependencies cause the algorithm to be trapped in local optima.

$$v(\omega + 1) = \sum_{n=1,3,5}^{\infty} \left(\frac{4vdc}{n\pi} \right)$$

$$V_1 \cos(\alpha_1^*) + V_2 \cos(\alpha_2^*) + \dots + V_r \cos(\alpha_r^*) = M r \left(\frac{\pi}{4Vdc} \right)$$

$$V_1 \cos(3\alpha_1^*) + V_2 \cos(3\alpha_2^*) + \dots + V_r \cos(3\alpha_r^*) = 0$$

$$V_1 \cos(5\alpha_1^*) + V_2 \cos(5\alpha_2^*) + \dots + V_r \cos(5\alpha_r^*) = 0$$

$$\dots$$

$$\dots$$

$$\dots$$

$$V_1 \cos(n\alpha_1^*) + V_2 \cos(n\alpha_2^*) + \dots + V_r \cos(n\alpha_r^*) = 0$$

where M is equal to modulation index.

II. CUCKOOS SEARCH ALGORITHM

The selective harmonic elimination or minimization for fundamental frequency operation cascaded multilevel inverters with separate dc sources. In CSA, has been used to determine the optimal switching angles for dc sources of equal values. Analytical solutions for this problem using the theory of symmetric polynomials were also reported for unipolar and bipolar schemes. An analytical solution for total harmonic distortion (THD) minimization is proposed, where the angles can be calculated for the case of equal dc sources. All of the previous papers, however, assumed that the dc sources are equal and do not vary with time. In analytical solutions for the case of unequal dc sources have been derived, and the algorithm is solved for the angles have been proposed.

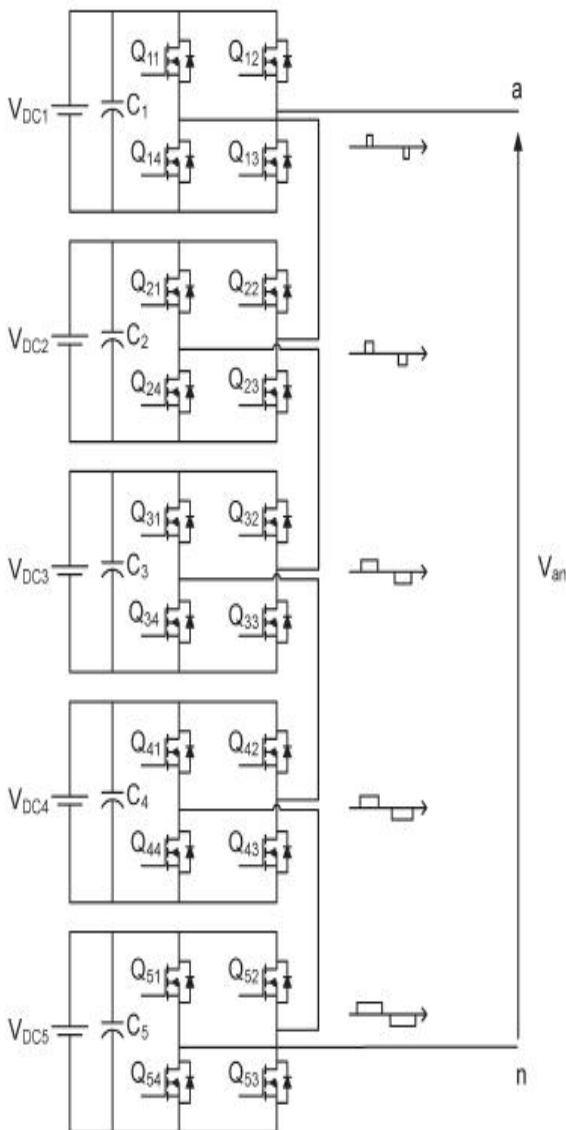

Fig 2 Eleven-level cascaded inverter

A. CSA

CSA is based on three idealized rules. Each cuckoo lays one egg at a time, and dumps it in a randomly chosen nest. The best nests with high quality of eggs (solution) will carry over to the next generations. The number of available host nests is fixed and a host can discover an alien egg with probability $P \in [0,1]$. In this case the host bird can either throw the egg away.

Completely build a new nest in a new location

Cuckoo based on the idea

Cuckoos lay their eggs in the host nests. If not detected and destroyed the eggs are hatched to chicks by the hosts. How a search algorithm based on such a scheme can be used to find the global optimum of a function.

B. Levy flights

In nature, animals search for food in a random manner. Foraging path of a animal is based on both the current location and the transition probability to the next location. Direct implicitly depends on a probability and modeled mathematically

C. Nearest neighbour

A nearest neighbour cuckoo search algorithm with probabilistic mutation, called NNCS. In the proposed approach, the nearest neighbour strategy is utilized to select guides to search for new solutions by using the nearest neighbour solutions instead of the best solution obtained so far. solution-based and a fitness-based similar metrics to select the nearest neighbour solutions for implementation. Furthermore, the probabilistic mutation strategy is used to control the new solutions learn from the nearest neighbour ones in partial dimensions only. In addition, the nearest neighbour strategy helps the best solution participate in searching too.

Randomly number generating RNG for the step angle theta and comparing with every before nearest neighbour cuckoos search NNCS.

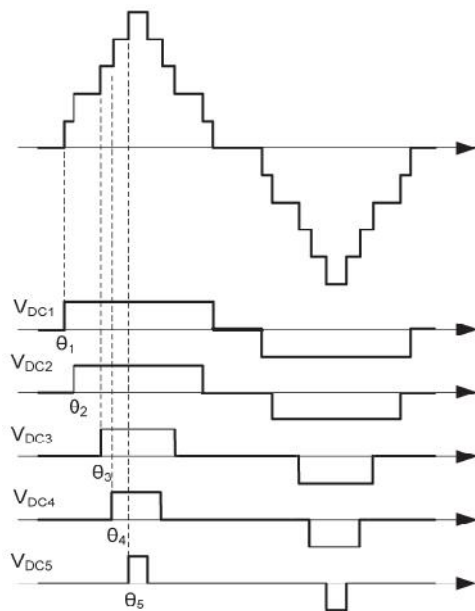

Fig 3 voltage output waveform modulation.

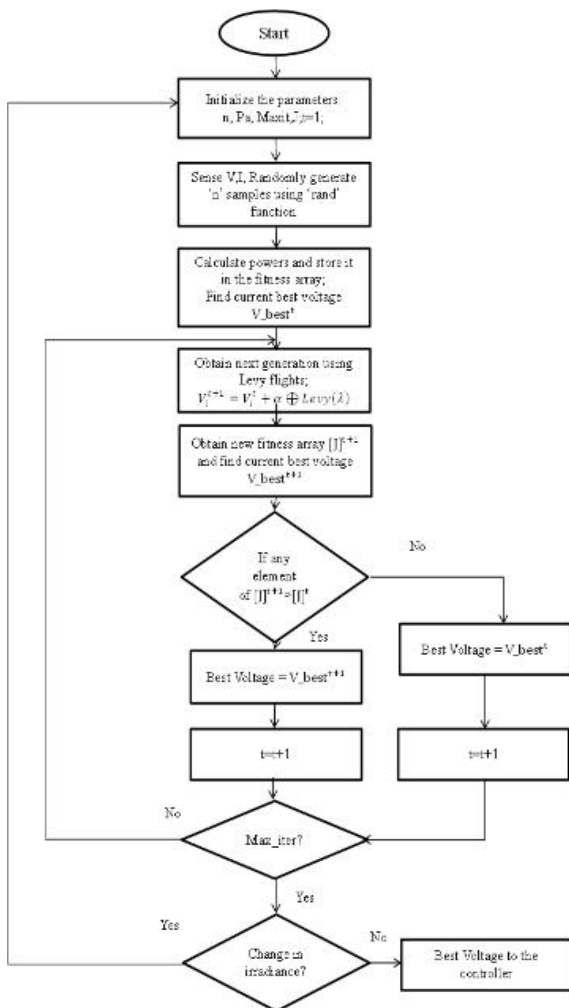

Fig 4 algorithm flowchart

program coding for CSA

```

function [bestfitness,mi]=CSA
Vs=20;
NL=input('Enter the No of level = ');
s= floor ( (NL/2) );
mi=input('Enter the value of Modulation index = ');
Population_size=50;
Lamda=2;sc = 2.5;
[X]=rand1(Population_size,s);
[Xfit]=fitne1(Vs,X,Population_size,mi,s);
[val,pos] = min(Xfit);
Best_Solution = val;
Best_Population = X(pos,:);
SWP = round(0.5*rand*Population_size);
SWP1=Population_size - SWP;
iter=1;
maxiter = 500;
while iter<= maxiter
Xn=zeros(Population_size,5);
ij = 1;
hjn = randperm(Population_size);
while ij<= Population_size
    flag2 = 0;
    ijkl = 1;
    [Xn,ij,Xnfit,flag2]=levy(Lamda,sc,ij,X,Best_Population,Xn,s,
    mi,Vs);
    if flag2 == 1
        ijkl = ij - 1;
    end
    if flag2==1 & (Xnfit(ijkl) < Xfit(hjn(ijkl)))
        Xfit(hjn(ijkl)) = Xnfit(ijkl);
        X(hjn(ijkl),:) = Xn(ijkl,:);
    end
end
[ab,bc] = sort(Xfit) ;
ir = SWP1;
while ir<= Population_size flag3 = 0;
    Population_size1 = 1;
    [X1,flag3]=neighbour(X,bc,s,Population_size,Lamda,sc,ir);
    if flag3 == 1    sdc=1;
    [Xfit1]=fitne1(Vs,X1,Population_size1,mi,s);
    Xfit(bc(ir)) = Xfit1;
    X(bc(ir),:) = X1;
    ir=ir+1;
else
    sdc1 = 1;
    [X1]=rand1(Population_size1,s);
    [Xfit1]=fitne1(Vs,X1,Population_size1,mi,s);
    Xfit(bc(ir)) = Xfit1;
    X(bc(ir),:) = X1;
    ir=ir+1;
end

```

```

end
end
[Best_Solution pos2] = min(Xfit);
Best_Population = X(pos2,:);
Best_Solution1(iter) = Best_Solution
Best_Population1(iter,:) = Best_Population
iter = iter + 1;
end
plot( Best_Solution1)
    Best_Solution1(maxiter)
bestfitness = Best_Population1(maxiter,:);
xlabel('Generation')
ylabel('Fitness Value')
    
```

III. SIMULATION DIAGRAM

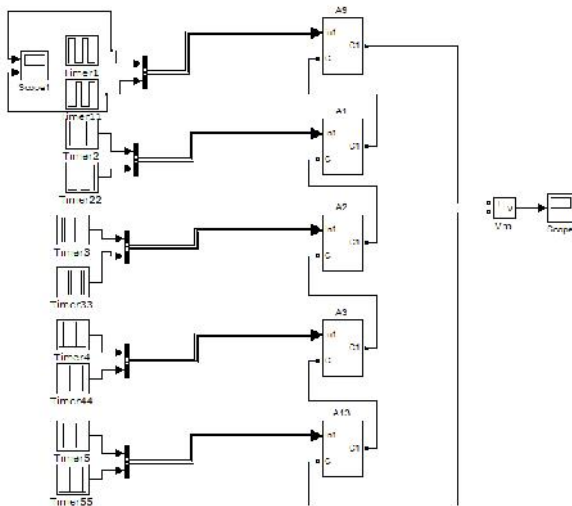

Fig 5 Simulation diagram

INNER BLOCK DIAGRAM

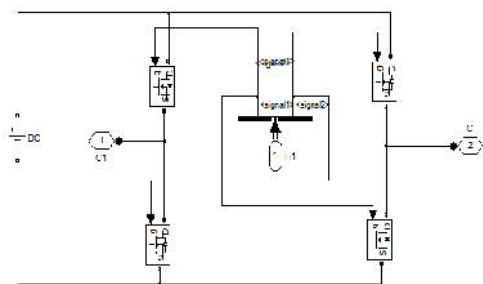

Fig 6 Inner block diagram

In order to verify the usefulness and effectiveness of the new proposed formulation, simulations and experiments based on SHE technique are carried out. Simulations were carried out on MATLAB 7.10 using a Pentium IV, Dual-core 2.21-GHz personal computer with 1 GB of RAM. It is assumed that the V_{dc} has the nominal value 1 p.u. in all MFCL.

The THD of output voltage is calculated up to the 55th harmonic. STHD minimization, eleven-level flying capacitor inverter is employed in the simulations.

A MOSFET

MOSFET and internal diodes are in parallel with a series RC snubber circuit. When a gate signal is applied the MOSFET conducts and acts as a resistance (R_{on}) in both directions. If the gate signal falls to zero when current is negative, current is transferred to the antiparallel diode.

B Inport

Provide an input port for a subsystem or model.

For Triggered Subsystems, 'Latch input by delaying outside signal' produces the value of the subsystem input at the previous time step. For Function-Call Subsystems, turning 'On' the 'Latch input for feedback signals of function-call subsystem outputs' prevents the input value to this subsystem from changing during its execution.

The other parameters can be used to explicitly specify the input signal attributes.

C Timer

Generates a signal changing at specified times.

If a signal value is not specified at time zero, the output is kept at 0 until the first specified transition time.

D Bus selector

This block accepts a bus as input which can be created from a Bus Creator, Bus Selector or a block that defines its output using a bus object. The left listbox shows the signals in the input bus. Use the Select button to select the output signals. The right listbox shows the selections. Use the Up, Down, or Remove button to reorder the selections. Check 'Output as bus' to output a single bus signal.

TABLE 1 TYPICAL VALUES OF k_i USED IN CALCULATIONS FOR THE 11-LEVEL CASE

INDEX	1	2	3	4	5	
0.6	35.9	49. 4	59. 3	69. 7	83. 3	< /2
0.7	25.6	43. 4	52. 8	68. 1	74. 2	
0.8	9.4	28. 4	40. 8	60. 4	72. 3	
0.9	8.5	25. 4	39. 2	50. 9	70. 1	
1.0	7.6	11. 1	26. 4	40. 8	57. 8	

All the Theta values are randomly searching and generating the pulse signals as the step angle. Every module of index values theta values are changed because of the number of iteration. As shown in table I

IV. SIMULATION RESULTS

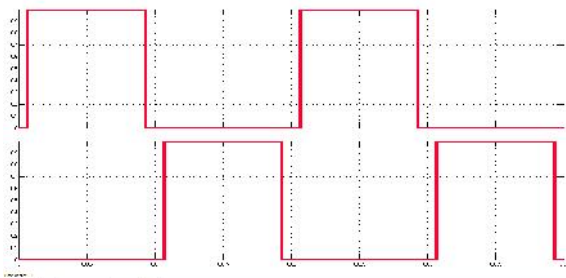

Fig 7 Timer pulse signals

These are the pulse signals for the timer 1 and timer 2 are shown in above figure 7. Due to this pulse signals step angles can be generated.

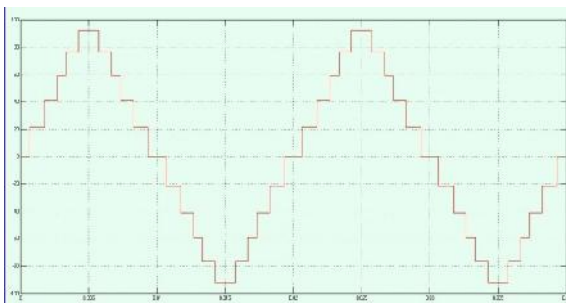

Fig 8 Module of index 0.6

This is an eleven level multi level inverter output waveform shown in this figure 6, the module of index 0.6 having the step angle based on the theta values shown in table

I. And the module of index 1.0 having better output compared to the module of index 0.6 as shown in figure 10.

The order of harmonic is having the value of 0.6 as shown in figure 9, this figure explains the selective harmonics elimination here 3rd order harmonics is reduced much better than the 1st order of harmonic and the 5th order is automatically eliminated in the three phase line. And the figure 11 shows that the order of harmonics is having the value of 1.0 here also selectively 3rd order harmonic is eliminated very much better than the 1st order harmonic.

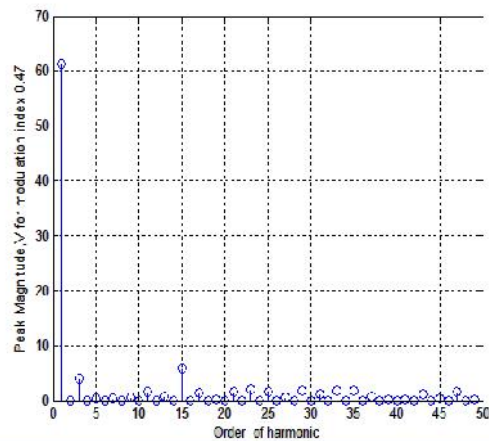

Fig 9 Order of harmonic 0.6

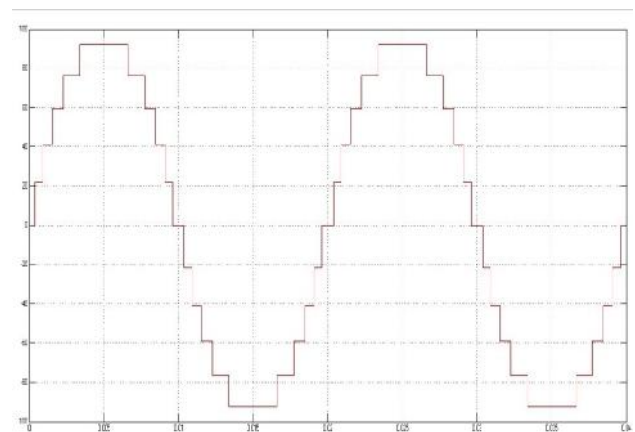

Fig 10 module of index 1.0

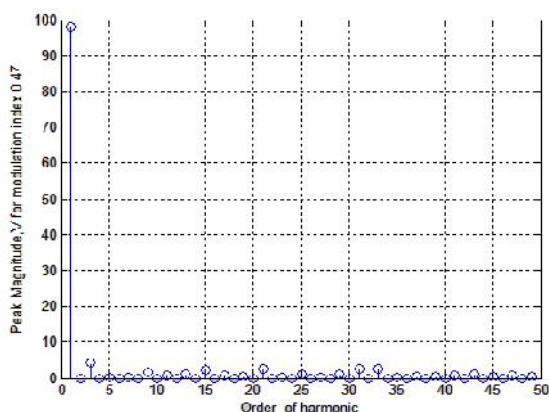

Fig 11 Order of harmonic 1.0

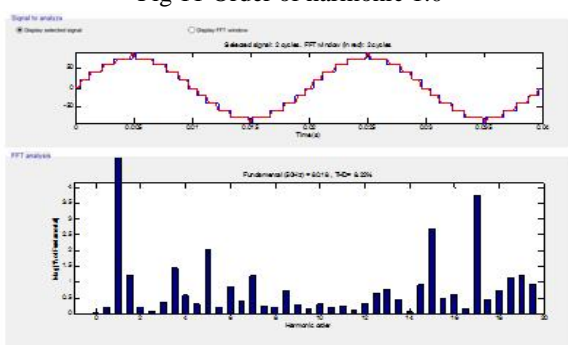

Fig 12 THD Result For Output Voltage

Figure 12 shows that the total harmonics distortion having 12 by using cuckoo search algorithm in eleven level multi level inverter.

V. CONCLUSION

This paper has presented the calculation of the switching angles based on the selective harmonic elimination scheme to minimize the total harmonic distortion (THD) of a multilevel flying capacitor inverter (MFCI). The STHD minimization strategy is capable to effectively minimize the practical THD of the MFCI, when the flying capacitor voltages are unbalanced and the switching angles are varied due to the mentioned effects. In the STHD minimization strategy, $2m + 1$ point estimate strategy is implemented to evaluate the values of VSAs and UFCVs. A MCSA has been introduced to determine the optimum switching angles of the MFCI.

REFERENCES

[1] Ajami A, Jannati-Oskuee M. R, Mokhberdorana and Van Den Bossche A, "Developed cascaded multilevel inverter topology to minimize the number of circuit devices and voltage stresses of switches," IET Power Electron., vol. 7, no. 2, pp. 459–466, Feb. 2014.

[2] Caro E, Morales J. M, Conejo A. J, and Minguez R, "Calculation of measurement correlations using point estimate," IEEE Trans. Power Del., vol. 25, no. 4, pp. 2095–2103, Oct. 2010.

[3] Chiasson J. N, Tolbert L. M, McKenzie K. J, and Du Z, "Elimination of harmonics in a multilevel converter using the theory of symmetric polynomials and resultants," IEEE Trans. Control Syst. Technol., vol. 13, no. 2, pp. 216–223, Mar. 2005.

[4] Dang D, Choi Y, Choi H, and Jung J, "Experimental validation of a fuzzy adaptive voltage controller for three-phase PWM inverter of a standalone DG unit," IEEE Trans. Ind. Informat., vol. 11, no. 3, pp. 632–641, Mar. 2015.

[5] Dolguntseva I, Krishna R, Soman D. E, and Leijon M, "Contourbased dead-time harmonic analysis in a three-level neutral - point - clamped inverter," IEEE Trans. Ind. Electron., vol. 62, no. 1, pp. 203–210, Jan. 2015.

[6] Druant J, Vyncke T, De Belie F, Sergeant P, and Melkebeek J, "Adding inverter fault detection to model-based predictive control for flying-capacitor inverters," IEEE Trans. Ind. Electron., vol. 62, no. 4, pp. 2054–2063, Apr. 2014.

[7] Du Z, Tolbert L. M, and Chiasson J. N, "Active harmonic elimination for multilevel converters," IEEE Trans. Power Electron., vol. 21, no. 2, pp. 459–469, Mar. 2006.

[8] Etesami M. H. Farokhnia N, and Fathi S. H, "Colonial competitive algorithm development toward harmonic minimization in multilevel inverters," IEEE Trans. Ind. Informat., vol. 11, no. 2, pp. 459–466, Apr. 2015.

[9] Fangang M, Wei Y, Shiyan Y, and Lei G "Active harmonic reduction for 12-pulse diode bridge rectifier at DC side with two-stage auxiliary circuit," IEEE Trans. Ind. Informat., vol. 11, no. 1, pp. 64–73, Feb. 2015.

[10] Farokhnia N, Fathi S. H, Salehi R, Gharehpetian G. B, and Ehsani M, "Improved selective harmonic elimination pulse-width modulation strategy in multilevel inverters," IET Power Electron., vol. 5, no. 9, pp. 1904–1911, Nov. 2012.

[11] Farokhnia N, Vadizadeh H, Fathi S. H, and Anvariasl F, "Calculating the formula of line voltage THD in multilevel inverter with unequal DC sources," IEEE Trans. Ind. Electron., vol. 58, no. 8, pp. 3359–3372, Aug. 2011.

[12] Fei W, Ruan X, and Wu B, "A generalized formulation of quarter-wave symmetry SHE-PWM problems for multilevel inverters," IEEE Trans. Power Electron., vol. 24, no. 7, pp. 1758–1766, Jul. 2009.

[13] Franquelo L. G, Rodriguez J, Leon J. I, Kouro S, Portillo R, and Prats M. A. M, "The age of multilevel converters

- arrives,” *IEEE Ind. Electron. Mag.*, vol. 2, no. 2, pp. 28–39, Jun. 2008.
- [14] Guzman J. I et al., “Digital implementation of selective harmonic elimination techniques in modular current source rectifiers,” *IEEE Trans. Ind. Informat.*, vol. 9, no. 2, pp. 1167–1177, May 2013.
- [15] Sundareswaran K and Kumar A. P, “Voltage harmonic elimination in PWM A.C. chopper using genetic algorithm,” *IEE Proc. Elect. Power Appl.*, vol. 151, no. 1, pp. 26–31, Jan. 2004.
- [16] Tarisciotti L, Zanchetta P, Watson A, Bifaretti S, and Clare J. C, “Modulated model predictive control for a seven-level cascaded H-Bridge back-to-back converter,” *IEEE Trans. Ind. Electron.*, vol. 61, no. 10, pp. 5375–5383, Oct. 2014.
- [17] Lin B and Huang C, “Implementation of a three-phase capacitorclamped active power filter under unbalanced condition,” *IEEE Trans. Ind. Electron.*, vol. 53, no. 5, pp. 1621–1630, Oct. 2006.
- [18] Wilkinson R. H, Meynard T. A, and Mouton H. D. T, “Natural balance of multicell converters: The general case,” *IEEE Trans. Power Electron.*, vol. 21, no. 6, pp. 1658–1666, Nov. 2006.
- [19] Yuan .X, Stemmler .H, and Barbi .I , “Self balancing of clampingcapacitor- voltages in the multilevel capacitor-clamping-inverter under sub-harmonic PWM modulation,” *IEEE Trans. Power Electron.*, vol. 16, no. 2, pp. 256–263, Mar. 2001.
- [20] Zobaa A. F. and Aleem S. H. E. A, “A new approach for harmonic distortion minimization in power systems supplying nonlinear loads,” *IEEE Trans. Ind. Informat.*, vol. 10, no. 2, pp. 1401–1412, May 2014.