

Medium Access Control For Detection of SIC-NOMA in Iot Networks

Sushma¹, Mr. Aashish Patidar²

¹Dept of Electronics & Communication Engineering

²Assistant Professor, Dept of Electronics & Communication Engineering

^{1,2} Anna University Regional Campus Coimbatore

Abstract- Computer and Wireless Networks have undergone a paradigm shift with the advent of big data. One of the most serious challenges of the present day networks in the medium access control domain is the rapidly increasing number of users and limited bandwidth. Hence multiplexing techniques which would utilize the available bandwidth resources effectively are being searched for. Non-Orthogonal Multiple Access (NOMA) has emerged as one of the promising options for future generation multiplexing solutions. In NOMA, the signals are separated in the power domain which allows the simultaneous transmission at the same time and frequency range thereby augmenting the spectral efficiency. However, due to multipath fading effects, power level separation is often complex to implement in real time situations. In this paper, NOMA based transmission mechanism has been proposed which employs decision feedback equalization along with successive signal detection based on power level separation. To emulate a real life scenario, different path gains have been considered for near, average and far users in a typical cellular network. The performance of the proposed system has been evaluated in terms of the bit error rate both without and with the proposed system being used. It has been shown that employing the proposed system, the error performance of average and far users almost coincide with that of the near users thereby indicating the fact that all users in the NOMA based system can be detected with almost identical accuracy.

Keywords- Medium Access Control (MAC), Non-Orthogonal Multiple Access (NOMA), Power Separation, Decision Feedback Equalizers, Multipath Components, Bit Error Rate (BER).

I. INTRODUCTION

With the advent of digital transmission, there has been a continuous search for effective multiplexing techniques. Different multiplexing techniques try to separate signals in different domains. For example, frequency division multiplexing (FDM) separates the signals in the frequency domain [1]-[2]. A more advanced version of the frequency division multiplexing is the orthogonal frequency division multiplexing (OFDM) in which the bandwidth efficiency is

higher than FDM due to the condition of orthogonality [2]. However, OFDM has its own challenges such as the inherent high peak to average power ratio (PAPR) and complexity in maintaining orthogonality among user signals. Another alternative is the time division multiplexing technique which as popular in second generation networks, with user signals being separated in the time domain. Off late, Non-Orthogonal Multiple Access (NOMA) has emerged as a promising multiplexing technique for wireless communications in which the bandwidth efficiency is much higher compared to OFDM [3]. In case of NOMA, signals are separated in the power domain. This necessitates the user signals to bear stark difference in power levels so that even while transmitting at the same frequency band and at same time slots, the separation among different signals can be accomplished [4]. The concept of Non-Orthogonal Multiple Access (NOMA) is depicted in figure 1.

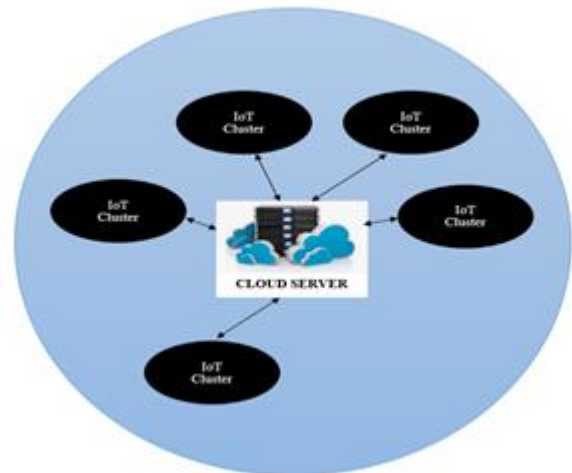

Fig.1.Macro Cells in IoT Networks

It can be observed from figure 1 that there is a large amount of bandwidth saving in case of using NOMA as compared with FDM and OFDM. A composite signal is however received at the receiving end of the cellular network which needs to separate out the signals. Considering $x(t)$ be the transmitted signal, If N co-efficients are represented by $A_1, A_2, A_3, A_4 \dots A_N$ and the strength of the reflections is $a_1, a_2, a_3, \dots, a_N$ then the weighted received signal $y(t)$ is given by:

$$(t) = a1(t) + a2x(t - A1) + \dots \dots aNx(t - AN) + (t) \dots(1)$$

Here,

$n(t)$ represents additive interferences or noise effects. Generally, the transmission channel is typically modeled digitally assuming a fixed sampling period T_s , thus equation (1) can be approximated as:

$$(kTs) = a1(kTs) + a2u(k1Ts) + \dots aNu(k - n)Ts + (kTs) \dots(2)$$

Equation (2) assumes that the signal is sampled for every T_s time slot. The composite signal at the receiver needs to be separated in such a way that all users are detected with identical accuracy [5]. The metric which is generally considered to evaluate the performance of the system is the error rate. One of the major challenges which the NOMA based transmission faces is the reduction is power separation among signals due to fading and noise effects [6].

II. THE SUCCESSIVE SIGNAL DETECTION APPROACH FOR NOMA

Typically, wireless channels depict frequency selective nature i.e. they behave differently for different frequencies. Moreover, the frequency selectivity is not fixed by also exhibits temporal variation [8]. This is depicted in figure 2.

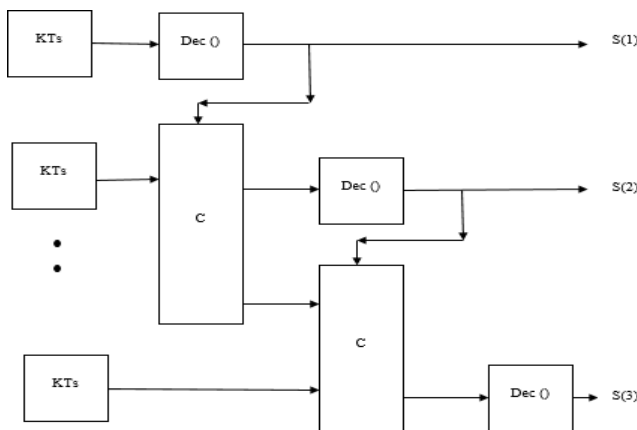

Fig. 2. The conceptual model for successive signal detection

The figure contains the following blocks:

KTs: It is the sampling block which samples the signal every $K T_s$ seconds

C: It is the canceller block

Dec(c): It is the decoder block

The successive signal detection mechanism is an iterative algorithm for the separation of signals in the power

domain. In this process, a multi-level comparison is made and the strongest signal is detected, stored and cancelled out from the composite signal. The detection starts with the strongest component and continues up to the weakest component. Since different paths have different gains given by (g) , the received composite NOMA signal can be given by:

$$(t) = x1(t)g1 + x2(t)g2 + \dots \dots (t)gn \dots(3)$$

Here,

(t) is the received composite NOMA signal

$(t)gn$ is the product of 'nth' transmitted signal with 'nth' path gain.

Typically the following cases would arise:

- 1) Near Users: The signals with the maximum path gains.
- 2) Average Users: The signals with intermediate or average path gains.
- 3) Far Users: The signals who have the least path gain.

The different path gains actually arise out of the difference in the path lengths of the different users located at different locations in the cellular network [9]-[10]. The successive cancellation approach helps to detect the multiple signals separated in the power domain [11].

III. PROPOSED SYSTEM FOR MEDIUM ACCESS CONTROL

The signals travelling through a wireless channel undergo the following detrimental effects:

- 1) Multipath Propagation
- 2) Noise effects

Multipath propagation makes the channel impulse response a weighted sum of impulses and also results in the interference effects at the receiving end [12]. The following composite impulse response can be considered for such a wireless channel:

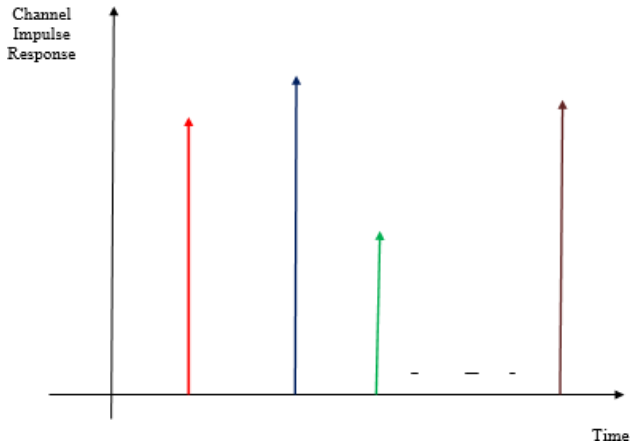

Fig. 3 Weighted impulse response of the channel

Mathematically, the composite impulse response of the channel can be given by:

$$h(t) = \sum (t - ir)g_i \quad \dots(4)$$

Here,

$h(t)$ is the composite channel response

δ represents the impulse function

g_i is the weight or gain of the 'ith' path

r is the delay in arrival of successive wave clusters due

to multi-path propagation

n is the total number of impulses

The noise effects are considered to be Gaussian with a constant two-sided power spectral density (psd) given by:

$$psd_{noise} = N_0/2 \nabla f: bandwidth \quad \dots(5)$$

Here,

psd stands for the power spectral density f stands for the frequency metric

N_0 is the one sided noise psd

The equalizer tries to nullify the effects of multi path propagation and noise effects. The equalization relies on the channel state information yielding the channel response (H). After obtaining the channel response (H), the inverse block is designed which is given by :

$$E = 1/H$$

Where, E is the equalizer response,

H is the sensed channel response.

The decision feedback equalizer (DFE) is employed in this approach which is depicted in figure 4.

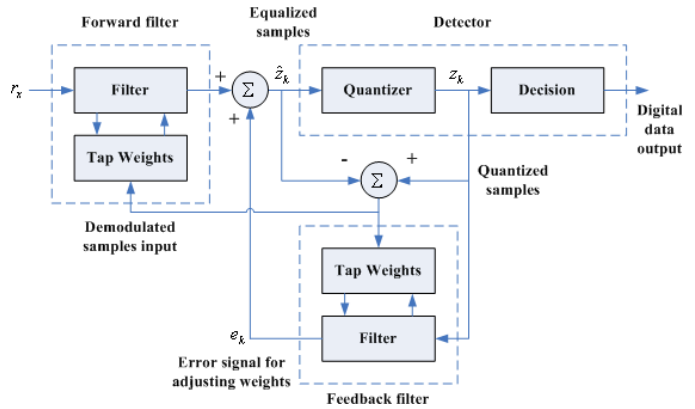

Fig. 4 Block diagram of decision feedback equalizer

The decision feedback equalizer adjusts the tap weights of the filter based on the actuating or error signal that is generated on comparing the dummy data transmitted and its copy received at the receiving end. The filter weights are updated every T_s seconds. In general, the sampling time of the receiver employing successive signal detection and that of the decision feedback equalizer are kept identical.

Finally, the detection of the signals at the receiving end is done based on the following conditions:

$$(T_s) = \sum_{i=1}^n (T_s) \quad (7)$$

Y_n is the composite received signal.

X_n represents the individual signals.

T_s is the sampling time

The signals are detected from strongest to weakest as:

$$y_k = \max(Y_n(T_s)) \quad (8)$$

Thus y_k is the strongest signal detected. It is stored and cancelled from the composite signal.

$$y^1 = (T_s) - y_k \quad (9)$$

Here,

y^1 denotes the cancellation of the strongest after the first iteration. This process is continued iteratively till all the signals are detected.

IV. SIMULATION RESULTS

The simulations are carried out for three cases:

- 1) Strongest User without proposed system

- 2) Average User without proposed system
- 3) Average User with proposed system
- 4) Weak User without proposed system
- 5) Weak user with proposed system

It can be seen that without the proposed system, the BER of the strongest user falls steeply while that for the average and far users fall slowly. This implies that the near users or the users with maximum path gain can be detected with maximum accuracy and the signal of the rest of the users would bear more errors. However, with the proposed approach, the BER curves of all the users coincide thereby rendering the condition of ideal error rate and reliability of detection for all user cases.

The BER performance of the proposed system has been listed in table I.

TABLE-I
PERFORMANCE ANALYSIS OF DIFFERENT BER FOR DIFFERENT CONDITIONS

S. No.	BER	SNR	Case
1	10 ⁻¹	0dB	Strongest User
2	10 ⁻¹	0dB	Weakest User without Proposed System
3	10 ⁻¹	0dB	Weakest User with Proposed System
4	10 ⁻¹	0dB	Average User without Proposed System
5	10 ⁻¹	0dB	Average User with Proposed System
6	10 ⁻²	4dB	Strongest User
7	10 ⁻²	10dB	Weakest User without Proposed System
8	10 ⁻²	4dB	Weakest User with Proposed System
9	10 ⁻²	8dB	Average User without Proposed System
10	10 ⁻²	4dB	Average User with Proposed System
11	10 ⁻³	7dB	Strongest User
12	10 ⁻³	N.A.	Weakest User without Proposed System
13	10 ⁻³	7dB	Weakest User with Proposed System
14	10 ⁻³	11dB	Average User without Proposed System
15	10 ⁻³	7dB	Average User with Proposed System

16	10 ⁻⁴	8.2dB	Strongest User
17	10 ⁻⁴	N.A.	Weakest User without Proposed System
18	10 ⁻⁴	8.4dB	Weakest User with Proposed System
19	10 ⁻⁴	N.A.	Average User without Proposed System
20	10 ⁻⁴	8.2dB	Average User with Proposed System
21	10 ⁻⁵	8.7dB	Strongest User
22	10 ⁻⁵	N.A.	Weakest User without Proposed System
23	10 ⁻⁵	10dB	Weakest User with Proposed System
24	10 ⁻⁵	N.A.	Average User without Proposed System
25	10 ⁻⁵	10dB	Average User with Proposed System

The BER curves for the different conditions are shown:

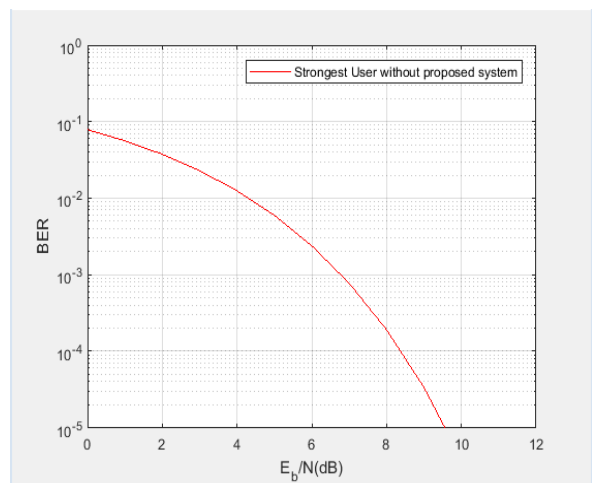

Fig.5 Strongest user without proposed system

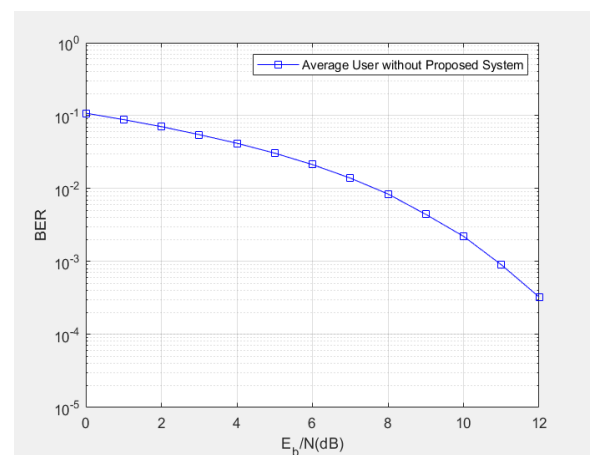

Fig.6 BER Analysis for Average User without proposed system.

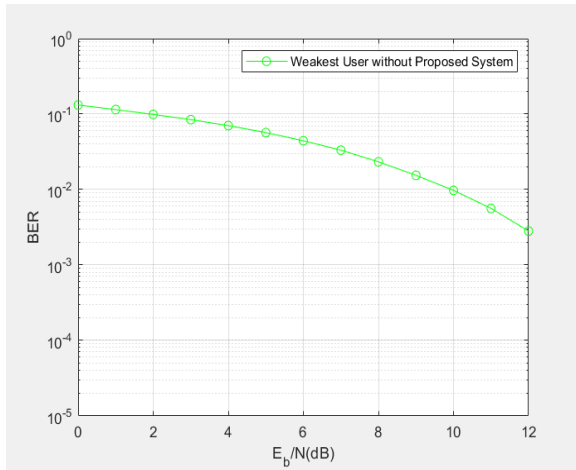

Fig.7 BER Analysis of Weakest User without proposed system.

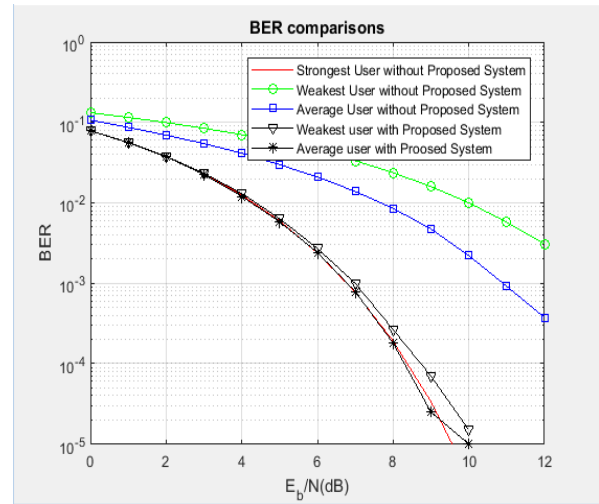

Fig.10 Comparative BER Analysis of Proposed System for all user cases

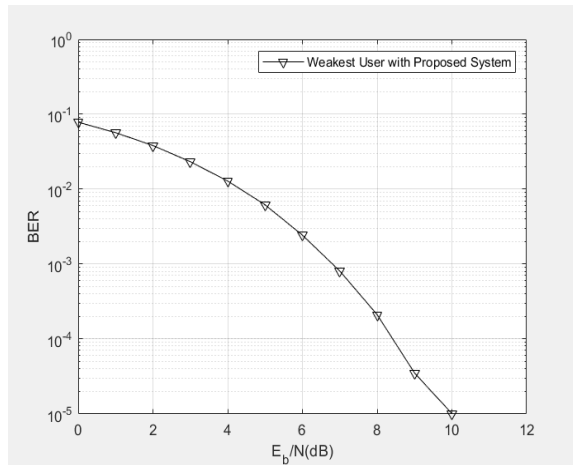

Fig.8 BER Analysis of Weakest User with proposed system.

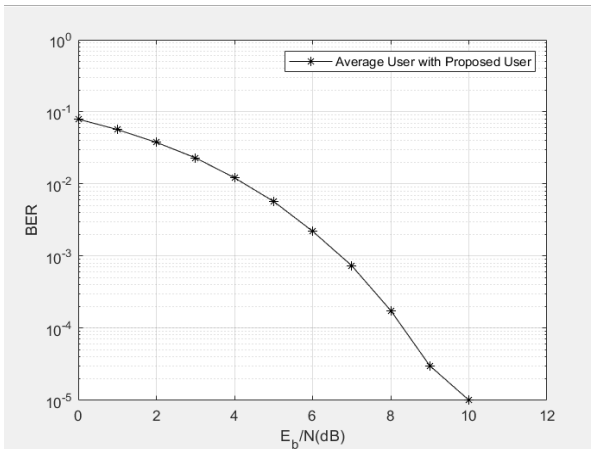

Fig.9 BER Analysis of Average User with proposed system.

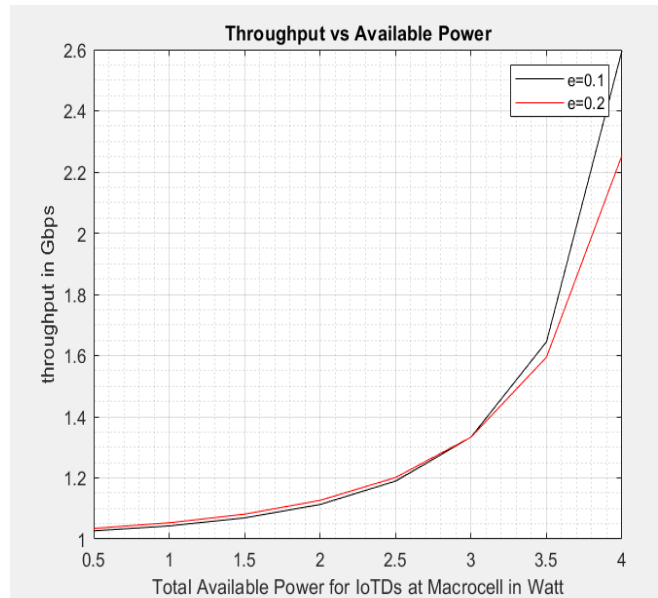

Fig.11 Throughput vs Available Power

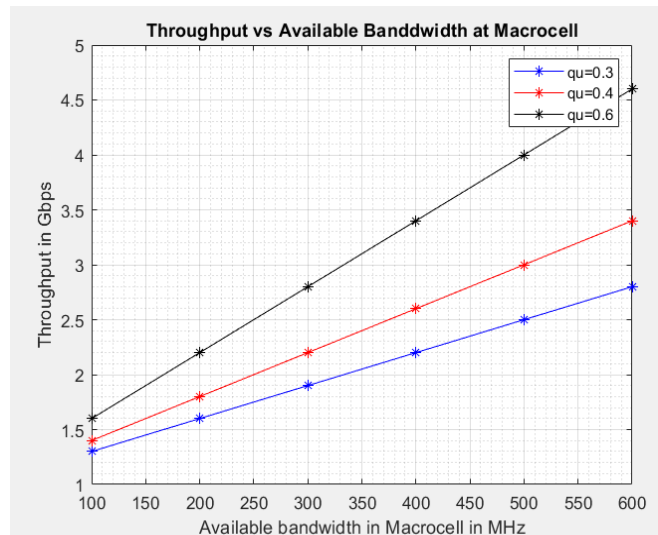

Fig.12 Throughput vs Available Bandwidth

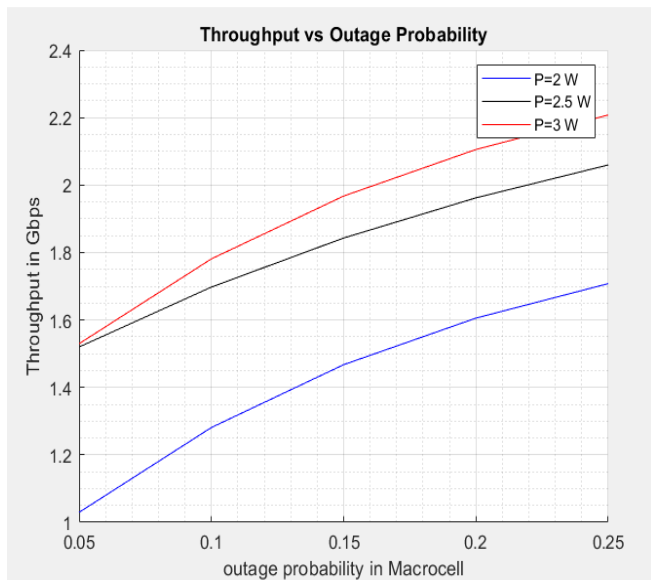

Fig.13 Throughput vs Outage

Table-I Comparative Results Analysis

S. N.	Parameter	Previous Work [1]	Proposed Work
1.	IoT Multiplexing Technique	NOMA	NOMA
2.	Decoding Technique	Bi-Convex Optimization (BCO)	Successive Interference Cancellation (SIC) + ZFE
3.	Maximum Throughput for Available Power (4 Watt)	2Gbps	2.6Gbps
4.	Maximum Throughput for available bandwidth (600MHz)	3.3Gbps	4.5Gbps
5.	Maximum Throughput for outage probability (0.25)	2Gbps	2.2Gbps

The comprehensive evaluation of the BER for the various cases and conditions has been analyzed. The simulation of BER has been operated for 10-1 to 10-5. The analysis could be obtained only for up to 10-5 as surpassing that value yielded relatively lower standards of communication quality in accordance with the Shannon’s limit. It limit usually takes into account the errors for a BER range of 10-5 to 10-6 as negligible. The range of SNR has

been selected as (0-12) dB attributing to the fact that there is convergence of the BER at around 10 dB. The term N.A here refers to not applicable and is generally refers to the case where it can’t reach the particular BER value in the specified range of SNR. A comparative analysis based on graphical and tabular representation also represents an evaluation of the proposed system that legibly illustrates that after the implementation of the system proposed, the BER obtained for average and weak receivers is almost similar with respect the strong users at SNR ranges which are identical. That infers achieving better and improved Quality of Service for the NOMA systems that have been deployed.

V. CONCLUSION

It can be concluded from previous discussions that IoT networks suffer from limitations in throughput and degradation in system BER. Massive IoT clusters share common resources such as bandwidth which is limited and needs to be utilized effectively. Hence in this approach, non-orthogonal multiple access (NOMA) based IoT macro-cells are designed with an aim to effectively utilize the bandwidth. The proposed system uses the successive interference cancellation (SIC) algorithm along with the zero forcing equalization mechanism to effectively decide the data of near as well as far users corresponding to weak and strong power levels. The throughput is computed with respect to the transmitted power, the available bandwidth at the macro-cells and the outage probability at the macro-cells. The BER is computed for weak, strong and average user scenarios in the macro-cells. It has been shown that the proposed system achieves very low BER values and outperforms the existing work [1] in terms of the system throughput.

REFERENCES

- [1] L Xu, W Yin, X Zhang, Y Yang, “Fairness-Aware Throughput Maximization over Cognitive Heterogeneous NOMA Networks for Industrial Cognitive IoT”, IEEE 2020
- [2] Yunlong Cai, Zhijin Qin , Fangyu Cui, Geoffrey Ye Li, Julie A. McCann, “Modulation and Multiple Access for 5G Networks”, Vol -20 , Issue -1, pp:629-646, IEEE Communications Surveys & Tutorials 2018
- [3] Wonjae Shin , Mojtaba Vaezi , Byungju Lee , David J. Love , Jungwoo Lee , H. Vincent Poor, “Non-Orthogonal Multiple Access in Multi-Cell Networks: Theory, Performance, and Practical Challenges”, Vol- 55 , Issue-10, pp:176-183, IEEE Communications Magazine, 2017
- [4] Zhiguo Ding , Xianfu Lei , George K. Karagiannidis ,Robert Schober , Jinhong Yuan , Vijay K. Bhargava, “A Survey on Non-Orthogonal Multiple Access for 5G

- Networks: Research Challenges and Future Trends” Vol – 35, Issue- 10, pp:2181-2195, IEEE Journal on Selected Areas in Communications, 2017
- [5] Yan Chen , Alireza Bayesteh , Yiqun Wu , S. Han ;,Mahmoud Taherzadeh , Dageng Chen , Jianglei Ma , “SCMA: A Promising Non- Orthogonal Multiple Access Technology for 5G Networks”, 2016 IEEE 84th Vehicular Technology Conference (VTC-Fall)
- [6] J Choi, J Mo, RW Heath, “Near maximum-likelihood detector and channel estimator for uplink multiuser massive MIMO systems with one-bit ADCs”, Vol-64, Issue-5, pp:2005-2018, IEEE Transactions on Communications 2016
- [7] Yunzheng Tao , Long Liu , Shang Liu , Zhi Zhang, “A survey: Several technologies of non-orthogonal transmission for 5G” , Vol- 12, Issue- 10, pp: 1-15, China Communications, IEEE 2015
- [8] Anass Benjebbour , Keisuke Saito , Anxin Li , Yoshihisa Kishiyama , Takehiro Nakamura, “Non-orthogonal multiple access (NOMA): Concept, performance evaluation and experimental trials” , Proceedings in 2015 International Conference on Wireless Networks and Mobile Communications (WINCOM).
- [9] Lili Wei , Rose Qingyang Hu , Yi Qian , Geng Wu, “Key elements to enable millimeter wave communications for 5G wireless systems” , Vol – 21, Issue – 6, pp:136-143, IEEE Wireless Communications, 2014
- [10] Pen-Shun Lu , Xiaobo Zhou , Tad Matsumoto , “Outage Probabilities of Orthogonal Multiple-Access Relaying Techniques With Imperfect Source- Relay Links”, Vol-14, Issue-4 ,pp: 2269-2280 IEEE Transactions on Wireless Communications 2014
- [11] Yuya Saito , Yoshihisa Kishiyama , Anass Benjebbour , Takehiro Nakamura , Anxin Li , Kenichi Higuchi, “Non-Orthogonal Multiple Access (NOMA) for Cellular Future Radio Access” , Proceeding in 2013 IEEE 77th Vehicular Technology Conference (VTC Spring)
- [12] Anass Benjebbour , Yuya Saito , Yoshihisa Kishiyama , Anxin Li , Atsushi Harada , Takehiro Nakamura, “Concept and practical considerations of non-orthogonal multiple access (NOMA) for future radio access” , Proceesings in 2013 International Symposium on Intelligent Signal Processing and Communication Systems.
- [13] J Umehara, Y Kishiyama, “Enhancing user fairness in non-orthogonal access with successive interference cancellation for cellular downlink”, Proceedings in 2012 IEEE International Conference on Communication Systems (ICCS).