

# Wireless Charger For Headphone

Ameya Agnihotri<sup>1</sup>, Sumeet Yadav<sup>2</sup>, Rutik Bandal<sup>3</sup>, Aniket Shastri<sup>4</sup>, Suvarna Shete<sup>5</sup>

<sup>1, 2, 3, 4, 5</sup> Dept of AS & H

<sup>1, 2, 3, 4, 5</sup> Pimpri Chinchwad College of Engineering

**Abstract-** A conductive charging system for headphones using a headphone stand is proposed in this paper. In this system a 5V output charger circuit is used to give power to the battery of headphones through the conducting metal plate placed on the top of the headphone's headband and another metal plate is attached on the headphone stand facing towards ground using a hinge mechanism so it can open and close. The Metal plates are magnetic so that they can stick to each other for current flow and then at last the power coming through the metal plates is transferred to the headphone's battery. It is almost a new kind of system that we can use to charge and place our headphones properly on the stand instead of keeping them here and there.

**Keywords-** Charging, headphone, stand, metal plates.

## I. INTRODUCTION

Wireless Power transmission has around been used for more than 100 years, when magnetic resonant coupling i.e., it is the ability to transmit electricity through the air by creating a magnetic field between two circuits, a transmitter and a receiver was demonstrated by Nikola Tesla. In recent times wireless charging is being used in charging smartphones, earphones, watches and also it is used for charging EVs in many countries around the world. Some European countries are leading in developing wireless charging which is better and more convenient. [3]

Today, wireless charging is enabled through different forms. All are aiming to cut cables. Wireless charging is making its way in the healthcare, automotive and manufacturing industries. As the industries are advancing day by day it requires a convenient way for charging. [3]

The widely used wireless charging technologies rely on an electromagnetic field between two copper coils, which limits the distance between the device and charging pad. [3] Mostly Wireless charging is enabled through different forms such as:

**Inductive Charging:** It uses electromagnetic waves to transfer energy and charge devices wirelessly. Inductive charging requires the device to be placed on a conductive charging pad/equipment, which is directly connected to a wall socket. It

is mainly used to charge small hand-held devices such as smartphones, PDAs and mobile phones. [1]

**Conductive charging:** It uses conductive power transfer to eliminate wires between the charger and the charging device. It requires the use of a charging board as the power transmitter to deliver the power, and a charging device, with a built-in receiver, to receive the power. Once the charging board recognizes the valid receiver, the charging begins. Conductive power transfer uses a conductor to connect two electronic devices in order to transfer energy. [2]

Technology is always getting better with time. Technology has both advantages and disadvantages.

Drawbacks of wireless charging technology:

1. Wireless charging is not convenient for the people who are always on the move. Instead, they use power banks for charging their devices.
2. Not all smartphones, watches, earphones, headphones are able to get charged by wireless charging. Today it is only available in expensive devices.
3. Wireless charging is slower than charging with a cable.
4. Wireless charging is more expensive than wired charging.
5. It is difficult to use the device because it is charging through wireless charging.

In our project we made a stand where headphones can be charged by keeping it properly on it. The stand has copper metal plate on it and when it comes in contact with another copper magnetic metal plate on top of the headphone's headband then power is transferred to the battery of headphone through USB cable which is connected to the plate.

## II. PROPOSED SYSTEM

In this system we have developed a headphone stand where we can keep and charge our headphones. Sometimes, we do not keep our accessories properly because of this our accessories get damaged accidentally so for keeping our accessory like headphones properly we have developed a stand which can also charge it. Headphones generally charge with 5V regulated DC supply, so we developed a circuit that can provide 5V regulated DC supply from 220 AC.

This circuit mainly consists of a step-down Transformer, a Full wave bridge rectifier and a 5V voltage regulator IC (7805). We can divide this circuit into four parts:

- 1) Step down AC voltage
- 2) Rectification
- 3) Filtration
- 4) Voltage Regulation.

Components used in the circuit are:

- 1) Transformer (9-0-9): It is used to step down voltage.



Figure 1

- 2) IC 7805: Used as voltage regulator.

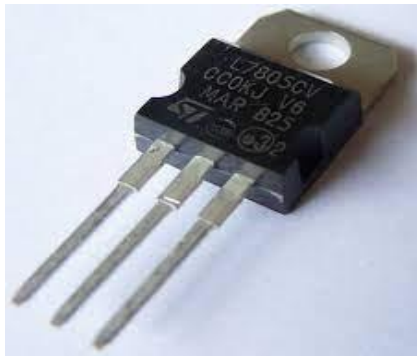

Figure 2

- 3) PCB: It is used to mechanically support and electrically connect electronic components.



Figure 3

- 4) USB Cables: Used to give connection.



Figure 4

- 5) Capacitors: Used to filter the input and reduce voltage pulsation.



Figure 5

- 6) Diodes (1N4007): Used to create a bridge rectifier.



Figure 6

### III.WORKING

**Circuit:**

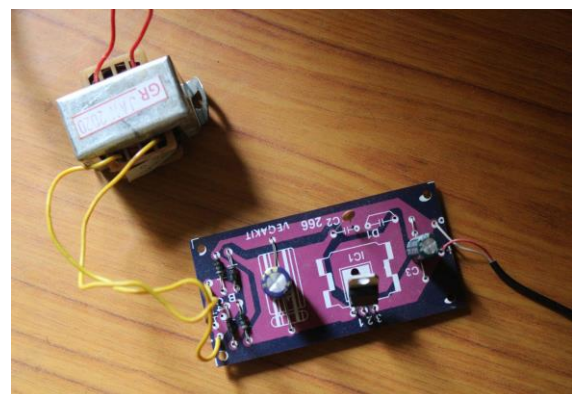

Figure 7

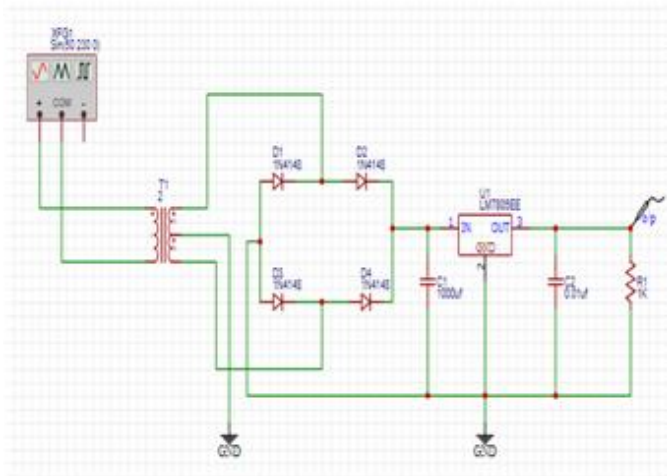

Figure 8

**Flow Chart:**

**Working of circuit:**

1) Firstly, there is an input of 220V AC. Then to reduce the voltage there is a step down transformer 9-0-9. Which converts 220V AC to 9V AC. The voltage rating should be more than required voltage. Means, if we need 5V DC, the transformer should at least have a rating of 7V, because the voltage regulator IC 7805 at least needs 2v more. i.e., 7V to provide 5V voltage.

2) Then Rectification is the process of removing the negative part of Alternate Current (AC), hence producing the partial DC. Therefore, by using 4 diodes, a Bridge rectifier is created which converts AC current to DC.

3) But output after rectification is not proper DC, it is oscillating output. So, Capacitor is used for Filtration. Capacitor maintains the proper voltage supply into the load circuit. Now purified DC is formed.

4) Then the IC 7805 is used to provide a regulated 5V DC. Voltage regulators have all the circuitry inside it to provide a proper regulated DC. Then a capacitor of 0.01µF is used in the output of the IC to eliminate the noise.

Hence, we get 5V Dc output.

**Working of stand:**

The stand works in four steps.

- 1) The flap containing a copper plate carrying current opens.
- 2) The headphones are placed on the stand.
- 3) The flap closes and conductions process takes place.

4) After the charging is done, the headphone is ready to remove by opening the flap.



Figure 9(a)



Figure 9(b)

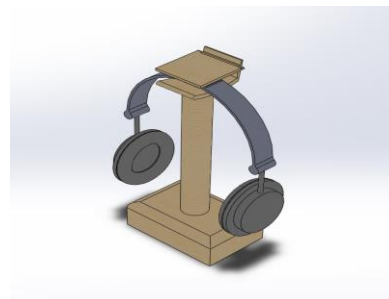
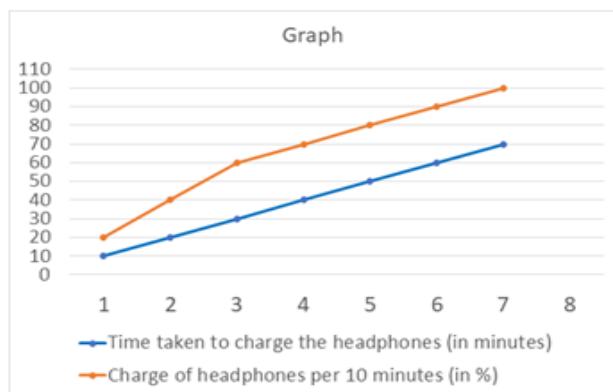

Figure 9(c)

**Observation Table:**

Time taken to charge the headphones (in minutes)	Charge of headphones per 10 minutes (in %)
10	20
20	40
30	60
40	70
50	80
60	90
70	100

**Graphical Representation:**



#### IV. CONCLUSION

This product “Wireless Headphone Charger” works on the basic principle of conductive wireless charging using two copper plates as conductors considered as +VCC and GND on both headphone as well as on the stand. To give support we have also added magnets behind both the copper plates so that they can give stability as well as prevent interchange of polarities. The 5V DC output helps to charge the headphone with ease. The stand is very durable and made from non-conducting material like wood or plastic. The charge is transferred using the copper plate placed on the headphone as well as on the stand. As shown in the graph and observation table it takes approximately 70-80 minutes to charge the headphone with 500 mAh battery. This is a quick faster than the standard time taken by the headphone to charge.

#### V. FUTURE SCOPE

Ample of future scopes are available, few of them are as follow:

- 1) A screen can be added which will show the battery percentage.
- 2) An additional USB port (type C, type A) for mobile charging can be added.
- 3) Protection circuits can be added to avoid short circuits or any further damage.
- 4) Changes can be made in the circuit to reduce charging time.

#### REFERENCES

- [1] Inductive charging - Wikipedia
- [2] [https://en.wikipedia.org/wiki/Conductive\\_wireless\\_charging](https://en.wikipedia.org/wiki/Conductive_wireless_charging)
- [3] Wireless charging explained: What is it and how does it work?
- [4] Cell Phone Charger Circuit Diagram
- [5] Wireless Power Hanger Pad for Portable Wireless Audio Device Power Charger Application
- [6] <https://www.grandviewresearch.com/industry-analysis/earphone-and-headphone-market>
- [7] <https://computerstationnation.com/best-headphone-stands/>