

Design and Development of Robotic Arm For Inpipe Inspection

Rahul Bhardwaj¹, H.P.S Kang²

¹Dept of Instrumentation

²Associate Professor

^{1,2}Panjab University, Chandigarh, India

Abstract- Pipelines are proven to be the safest way to transport and distribute gases and liquids. Periodic inspection is required to maintain that status. Pipeline systems deteriorate progressively over time through various means. The specific operations such as inspection, maintenance, cleaning etc. are expensive. Thus, the application of the robots appears to be an attractive solution. The project aims to create a autonomous robot used for in-pipe inspection. The mechanism used involves a central rod upon which a translational element is fitted which in turn is connected to three frames of links and wheels. DC motors are attached to the wheels to achieve the drive required. The mechanism allows for small accommodation in pipe diameters. An electronic circuit consisting of three relay switches is used to control the entire circuitry of DC motors, camera and translational element. The camera is mounted on the top of the assembly, which in itself can be rotated thus giving a wide field of view in the pipe. The robot allows for detection of cracks, buckle, corrosions, pitting and many others. The mechanism allows for small accommodation in pipe diameters. Some of the researchers ran simulations to validate the kinematic and modeling the mechanism of their own prototype. Developing in-pipe inspection robot can overcome the issues of human factor in labour intensive or dangerous work and also to act in inaccessible environment during repair and maintaining inside the pipeline.

Keywords- Ultrasonic sensor, DC Motors, Arduino Uno, Translational element, Inpipe Inspection.

I. INTRODUCTION

Pipelines are proven to be the safest way to transport and distribute gases and liquids. Periodic inspection is required to maintain that status. Pipeline systems deteriorate progressively over time through various means. Robotics is one of the fastest growing engineering fields of today. Robots are designed to remove the human factor from labour intensive or dangerous work environments and also to act in inaccessible environment. The specific operations such as inspection, maintenance, cleaning etc. are expensive. Thus, the application of the robots appears to be an attractive solution.

The project aims to create a robotic inspection technology. It is beneficial to have a robot with adaptable structure to the pipe diameter, which possesses enhanced dexterity, maneuverability and capability to operate under hostile conditions. Wheeled robots are simple, energy efficient and have a great potential for long range usage which offers few advantages in maneuverability with the ability to adapt to in-pipe unevenness, move vertically in pipes, and stay stable without slipping in pipes. This type of robot also has the advantage of easier miniaturization. A challenge in its design and implementation consists in combining the mobility with that of autonomy and low weight. Major design objectives are represented by the adaptability of the robot to the inner diameters of the pipes and making the machine autonomous.[1]

II. DESIGN PARAMETERS

The parameter for design of the robot is the diameter of pipe. We have chosen 8'' and 11'' (approx. 204 mm and 280 mm) pipes as the lower and upper limits respectively for our robot.

Selection of the wheel:

The wheels of the robot should be chosen such that they should be capable of moving without slipping in the vertical direction by exerting the required traction force. They should also not wear out easily with use. These factors are determined by the co-efficient of friction between the wheel and the pipe. Rubber wheels are a natural choice for this environment as they meet the above demands. The co-efficient of friction between rubber and two commonly used pipe materials (concrete and PVC) are considered. Coefficient of friction between rubber and concrete is in the range of 0.6 – 0.85. Coefficient of friction between rubber and PVC is in the range of 0.5 – 0.7. The power requirements are calculated using a coefficient of friction of 0.8. The range of diameter of pipes considered in the present work is 204 to 280 mm. To accommodate the mechanism with rubber wheels and considering market availability of standard wheels, the diameter was chosen to be 80 mm.

Mechanism Synthesis:

The robot mechanism is to be designed in such a way as to expand and contract between the chosen limits. This necessitates the use of a mechanism where the input link causes the other links to move in a uniform fashion without any crossovers. A parallelogram linkage offers the required type of uniform motion.

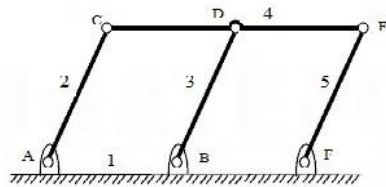

Fig.1: Simple Parallelogram Mechanism

But, the required way of motion is not achieved from this design. The joint F is made into a screw pair. The orientation of link 5 is changed so that when the input, link 2 moves in the clockwise direction, link 5 moves in the opposite direction pushing the screw pair forward and vice versa. This combination of linkages makes the mechanism contract in the clockwise direction and expands in counter clockwise direction.

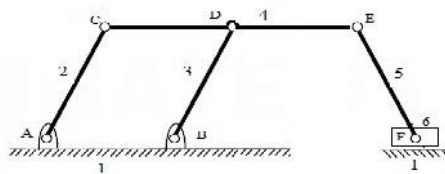

Fig.2: Modified Mechanism

Link dimensions are to be equal for execution of uniform motion. For the pipe diameter range of 200 mm to 280 mm, link length can be varied. Angular position of link at the maximum diameter must not exceed 90° and not go below 45° for proper functioning. The link dimensions can vary from 65 to 85 mm with angles ranging from 67.4° to 44.9° respectively at max diameter of 280 mm. Degrees of freedom of the mechanism is obtained from Gruebler’s criterion,

$$F=3(N-1)-2L$$

Where, F – Number of degrees of freedom, N – Number of links, L – Number of lower pairs, H – Number of higher pairs. Substituting the values, we get F = 1, hence it is a single degree of freedom system.[2]

Material Selection:

The materials used for this machine are to be rigid. Different materials can be used for different parts of the robot. For optimum use of power the materials used should be light and strong. Wood is light but it is subjected to wear if used for this machine. Metals are the ideal materials for the robot as most of the plastics cannot be as strong. Material chosen should be ductile, less brittle, malleable, and have high magnetic susceptibility. Among the metals/metal alloys, aluminium is a good choice. But, mild steel 1018 was chosen as the material for links and a translational element as it is sufficiently rigid and less brittle. It balances ductility and strength and has good wear resistance; used for large parts, forging and automotive components. However, mild steel is denser compared to aluminium and makes the robot heavier. C45 steel is chosen as the material for screw rod as it is a medium carbon steel, which is used when greater strength and hardness is desired than in the "as rolled" condition. Extreme size accuracy, straightness and concentricity combine to minimize wear in high speed applications. It is generally used for screws, forgings, wheel tyres, shafts, axes, knives, wood working drills and hammers.[3]

Design calculations:

The material chosen is C45 steel. The diameter of a shaft with bending moment and torsional moment is given by the relation below.

$$d^3 = \frac{16}{\pi \tau_{max}} \times \sqrt{(C_m M)^2 + (C_t T)^2}$$

where

d = diameter of screw rod, m

C_m= numerical shock and fatigue factor for bending moment

C_t = numerical shock and fatigue factor for torsional moment

τ_{max}= maximum shear stress, MN/m²

M = bending moment, Nm

T = torsional moment, Nm

C_m= 1.5 and C_t = 1.0 for rotating shafts with gradual or steady load

σ_y=353 MPa for C45 steel

d = 0.007922 m = 7.922 mm 8 mm.

Therefore diameter of screw rod is 8 mm.[4]

Motor power calculations:

Gross robot weight, W= 4.67 kg * 9.81m/s² = 45.81 N

Weight per wheel, W_w =45.81/6= 7.64 N

Power required per wheel, P=2 NT/60 = 1.54 W

Force on the screw rod due to torque from the motor:

$$T = \frac{W}{2} \left[d_2 \left(\frac{\tan \alpha + f \sec \theta}{1 - f \tan \alpha \sec \theta} \right) + f_c d_c \right]$$

Where,

T – Torque applied, Nm

W – Force acting on the screw rod, N

d_2 = Pitch diameter of external thread, m

f_c = Friction coefficient between nut and screw

d_c = mean diameter of the friction collar, m

α = Helix angle, deg

θ = Half apex angle, deg

p = Pitch of thread = 1.25 mm

$\alpha = 3.088^\circ$

$\theta = 30^\circ$ for V- threads

$f = 0.5$

$d = 7.16$ mm for M8 screw thread

W = 194.5 N

The yield strength of 1018 steel is 353 MPa. As $3.47 < 353$ MPa, there will be no distortion or failure of the links.

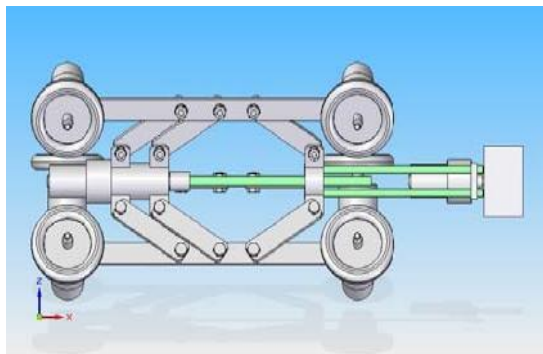

Fig.3: Assembly-Front view

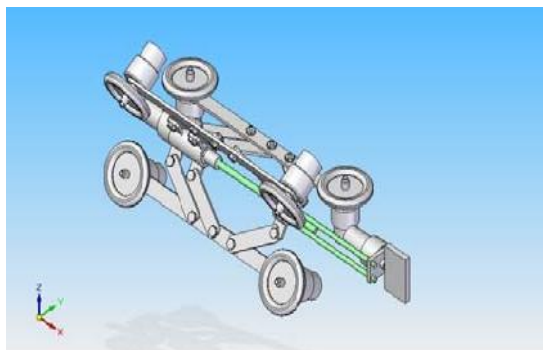

Fig.4: Assembly-Isometric view

III. FABRICATION AND WORKING

The fabrication phase of the project involves production of the parts designed. It also entails the selection of appropriate electronic circuitry which can be effectively used to achieve and control the robot motion. The various processes used in fabrication of the components are Cutting Drilling Welding Turning.[5,6]



Fig.5: Holes drilled on links

Electronic circuit and components:

The assembled robot needs to start or stop instantaneously. Also, its direction of motion ought to be easily switched over. This can be achieved by using Arduino Uno which is an open-source electronics platform based on easy-to-use hardware and software. Arduino boards are able to read inputs - light on a sensor, a finger on a button, or a Twitter message - and turn it into an output - activating a motor, turning on an LED, publishing something online. The Arduino Uno is programmed using the Arduino Software (IDE), our Integrated Development Environment common to all our boards and running both online and offline.

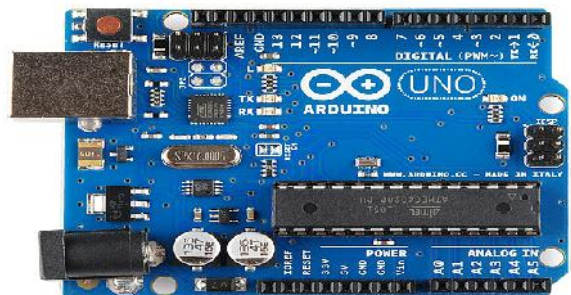

Fig.6: ARDUINO UNO

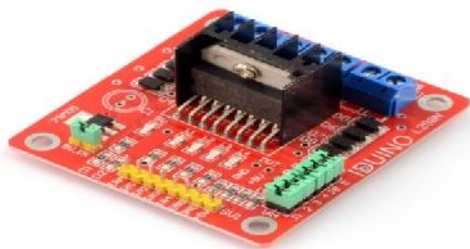

Fig.7: HL 298N

HL 298 N bridge :

The L298N is a dual H-Bridge motor driver which allows speed and direction control of two DC motors at the same time. The module can drive DC motors that have voltages between 5 and 35V, with a peak current up to 2A. The L298N Motor Driver module consists of an L298 Motor Driver IC, 78M05 Voltage Regulator, resistors, capacitor, Power LED, 5V jumper in an integrated circuit.

DC motor:

DC (direct current) motor works on the principle, when a current carrying conductor is placed in a magnetic field; it experiences a torque and has a tendency to move. If the direction of current in the wire is reversed, the direction of rotation also reverses. When magnetic field and electric field interact they produce a mechanical force, and based on that the working principle of dc motor established. DC motors are used to achieve the drive on wheels and rotation of rods. Two types of DC motors used in the project are shown in Fig below:[7,8]



Fig.8: 200 and 60 rpm DC motor

Circuit integration and assembly:

At the end of fabrication, the electronic circuitry is implemented onto the robot. The DC motors are fitted for the wheels, screw rod and camera plate rod. The 4 channel relay is integrated with all the DC motors. Appropriate wiring is done and battery is connected to all electronic components. The fully assembled robot is shown in fig. below:



Fig.9: Fully assembled pipe inspection robot

Working :

The complete assembly of the robot leads to the next phase of the project Here the robot is checked for its performance of the desired functions. Drive to the wheels is achieved through DC motors. These motors are connected through relay switches which govern the start/stop functions and rotational direction of the motors. The robot works through the electronic circuit-mechanism interface. Once placed sufficiently inside the pipe, the manual relay switch is actuated to expand the frames so as to accommodate to the pipe diameter. The expansion is continued till sufficient gripping is achieved. The gripping ensures motion in horizontal or vertical direction. As the robot moves inside the pipe, wireless signals are conveyed to the receiver giving a view of the inside surface. The surfaces are checked for defects visually.[9,10]

Results:

Pipeline systems are prone to degradation and corrosion resulting in a number of defects. Identification of defects is an important problem in chemical plants, sewage pipes and other industries. This project aimed to create an autonomous robot for in-pipe inspection capable of vertical and horizontal motion. The following results were obtained from the completion of the project. The robot was capable of adapting to pipe diameters in the range of 204 mm to 280 mm. The robot was tested for motion in a 250 mm PVC pipe. It was found to move well in horizontal & vertical direction. The velocity of the robot is 30 cm/s.

IV. CONCLUSION

Robots can be effectively used as tools to carry out work in labor intensive, hazardous and unreachable work environments. Pipeline systems are one such environment. Robots can be successfully implemented in pipe line inspections for better detection of defects. The project aimed

to create an in-pipe robot with adaptable structure, autonomy and achieve vertical motion.

V. ACKNOWLEDGEMENT

I am thankful to Panjab University, UCIM department for providing me the lab and necessary equipments for my experiments and my guide Associate Professor H.P.S Kang for their support and guidance.

REFERENCES

- [1] Dr. Sharanabasappa C. Sajjan , Naveen Srivatsa H.S, Dinesh Kumar P Faculty PESIT- Bangalore South Capus, Student PESIT-BSC, 3Student PESIT-BSC: DESIGN AND DEVELOPMENT OF PIPE INSPECTION ROBOT
- [2] Dongwoo Lee, Jungwan Park, Dongjun Hyun, Gyung Hwan Yook and Hyun-seok Yang, Novel mechanisms and simple locomotion strategies for an in-pipe robot that can inspect various pipe types, Mechanism and Machine Theory 56 (2012), pp 52-68.
- [3] Atul Gargade, Dhanraj Tambuskar and Gajanan Thokal, Modeling and Analysis of Pipe Inspection Robot, International Journal of Emerging Technology and Advanced Engineering, Volume 3, Issue 5, May 2013, pp 120-126.
- [4] Young-Sik Kwon,Byung-JuYi,Design and Motion Planning of a Two-Module Collaborative Indoor Pipeline Inspection Robot, IEEE, 2012,pp. 1-16.
- [5] AH Heidari, H Najjaran, M Mehrandezh, RParanjape - 2010 - cdn.intechopen.com, Design, development, dynamic analysis, and control of a pipe crawling robot.
- [6] MINIATURE AUTONOMOUS ROBOTS FOR PIPELINE INSPECTION :William Tyler Moss, James G. Boyd, Raktim Bhattacharya, Richard Malak, Rodney Bowersox.
- [7] Dinesh KumarD.S,Bi Kadejatul Kubra, Jennifer J, Varsha P,Varsha Rani Sah: International Research Journal of Engineering and Technology (IRJET) PIPE INSPECTION ROBOT.
- [8] Md Raziq Asyraf Md Zin, Khairul Salleh Mohamed Sahari, Juniza Md Saad, Adzly Anuar, and Abd Talip Zulkarnain, Development of a Low Cost Small Sized In-Pipe Robot International Symposium on Robotics and Intelligent Sensors 2012 (IRIS 2012), pp 1469-1475.
- [9] POOJA GM ,KAVYASHREE MS,NIHARIKA SN, CHANDRASHEKHRA GN : IN PIPE INSPECTION ROBOT , International Journal of Engineering Research & Technology (IJERT) ,ISSN: 2278-0181 ,Published by www.ijert.org ,NCESC - 2018 Conference Proceedings.
- [10] Ankit Nayak a, S. K. Pradhan : Design of a New In-Pipe Inspection Robot. 12th GLOBAL CONGRESS ON MANUFACTURING AND MANAGEMENT, GCMM 2014.