

Performance Analysis of Power Sepic Converters For Grid Connected Hybrid Solar And Wind Energy System

Mr.D.Santhoshkumar¹, B.Nishapriya², T.Selvalakshmi³

^{1,2,3} Assistant Professor, Dept of Electrical and Electronics Engineering

^{1,2,3} Vivekanandha College Of Engineering for Women, Namakkal, Tamilnadu, India

Abstract- The power generation from the photovoltaic (PV) and wind energy conversion system (WECS) sources has been increased notably, due to its alternative availability nature during a day. In this work, different power electronic converters are integrated together by sharing and merging power converter components between the DC-DC converters to develop a hybrid power converter. The hybrid Cuk and single ended primary inductor converter (SEPIC) is derived from the traditional SEPIC converters by rearranging the diodes D1 and D2 in the SEPIC converters and also by distributing the output inductor, L2 of the Cuk converter by the SEPIC converter. Similarly, Hybrid converter is arranged from the classical super lift converter by allocating the charging capacitor, C1 and DC link capacitor, C2 between the two converters. The proposed methodology tested at various conditions for all the three time sections and the obtained results shows that the SEPIC converter gives the higher efficiency compared to the SEPIC converter. Piecewise Linear Electrical Circuit Simulation (PLECS) controller is used to validate the efficacy of developed hybrid RES system for real time analysis. The obtained outcomes with PLECS controller illustrates the proposed work will be useful for integration of different renewable energy sources in real time.

Keywords- Cuk converter, Hybrid DC-DC Converter, Luo converter, PV system, SEPIC converter, Single MPPT controller, Wind System

I. INTRODUCTION

Our civilization depends much on electricity and the utilization of electricity will increase the standard of living of human beings. In the up to date world, for generating power fossil fuels can be taken as the chief sources in meeting the load demand. But, the main disadvantages of these are as such nature exhaustible which causes heavy impact towards environmental calamities those are yet to be exhausted in futuristic decades since they are non-renewable [1]. In literature photovoltaic (PV) and wind energy conversion system (WECS) sources are the most promising RES and its

grid-tied cumulative installed capacity in India has reached 71,187.12 MW, in which PV contribution is 23,022.83 MW, which is 33 % and wind contribution is 34,293.48 MW which is 48 % along with hydro power and biomass as of the 30th June, 2018 [3].

To till date, investigation on power and generation are geared up in the direction of the RES due to free from pollution and its abundance in nature. The drawback of RES is that it is quite difficult to generate a required quantity of electric power in a short span to meet the demand and their output is depends on availability of environmental/natural sources, which are unpredictable and uncontrollable in nature [4]. Understanding the problem, the renewable energy sources has random behavior during the day. From the basic topology of hybrid renewable energy system, it requires more number of power electronic converters for grid integration, and it undergoes more number of power conversion stages to meet the integration requirement of renewable energy sources. From this, converter efficiency and power electronic converter components required for integration act as a major role in the hybrid RES [5]. Another important challenge in the hybrid RES system is to extract MPP from PV and WECS. In this basic topology, it needs an individual and dedicated MPPT control algorithm for the individual RES.

This research work focuses on the performance analysis of hybrid solar and WECS with hybrid power electronic converter with single MPPT controller for both standalone and grid-connected applications. This study is relied on considering the speed of the wind as well as PV irradiation as inputs. The main objectives of the research works are listed. [6],

- To model a hybrid PV and WECS by considering BP SX3190 PV module and Aeolos-H 500 W wind model data sheets in MATLAB/Simulink.

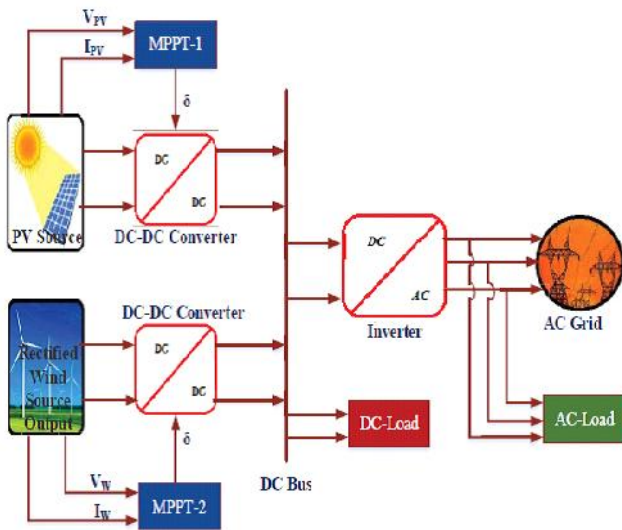

Fig. 1 Hybrid PV and WECS Basic Topology

- Surveying various power electronic converter configurations and MPPT control techniques available for integration of RES to make a hybrid system and to extract MPP.
- To develop a hybrid DC-DC converter for hybrid PV and WECS.
- To develop a single intelligent MPPT controller for hybrid PV and WECS to extract MPP from both the sources concurrently.
- Comparisons are made based on the availability of PV irradiation and speed of the wind system input data, under three different time sections for both SA and GC modes [7].

The rest of this paper is organized as follows. Section II provides the brief review existing RES in various Converter. Section III provides the details proposed methodology of res converter. Section IV shows the Experimental results to evaluate the performance and comparison Section V includes conclusion

II. LITERATURE REVIEW

In hybrid system, distinct types of PECs are utilized for amalgamation of assorted energy sources. The probable formations of hybrid systems are principally AC shunt coupled, DC shunt coupled in addition to hybrid coupled systems Li et al. (2010). Normally for generating wind, back-to-back AC/DC/AC converter is preferred and for PV boost converter along with inverter is employed. If both RESs are assimilated together, then the system makes use of an independent PEC by integrating some component of converters to lessen about 25% of power semiconductor switches Tiwari and Babu (2016).

The authors Bayrak and Cebeci (2014) developed a basic module of grid connected hybrid power system which comprises PV and solid oxide fuel cell (SOFC). A 160 Wp PV panel was developed by considering the real data sheet of DPS-160 PV module parameters, as shown in FIGURE 2. By using these panel 800 Wp PV generators is connected to the grid. To support the DC bus in the hybrid system a 5 kW SOFC was designed. The entire hybrid RES system is designed and analyzed using MATLAB/ Simulink software.

Advanced power controller has been developed by Hirose and Matsuo (2012), to control the active, reactive and dump power in a standalone hybrid system. The developed controller will monitor the power status of individual sources through a communication line and send ON/OFF commands to the power sources. After receiving the ON command individual sources will operate with their dedicated inverter to supply the load.

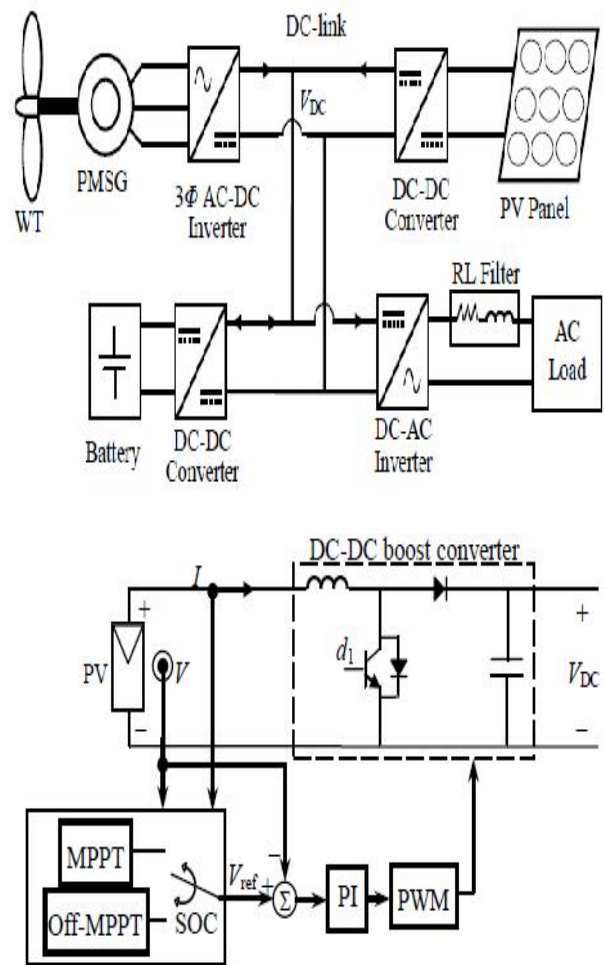

Figure 2 Existing System block diagram and Circuit diagram

Incremental conductance technique is one more technique which is utilized in both PV and wind system Ram et al. (2017), owing to its ability in handling the non-linear characteristics to pullout MPP. It senses voltage and current from the RESs and tracks MPP by computing the ratio between prompt conductances to the incremental one. It is not as much of multifaceted and easy to implement when compared to the other accessible MPPTs in writings.

Even through the aforementioned wide-reaching controller pertinent for PV and wind sources to pull out MPP, it entails independent out-and-out MPPT algorithms for each source, which in turn intensifies the price, size, intricacy in operation of the hybrid RES system. To overcome the downsides, two MPPT control algorithms are proposed, a modified single P and O MPPT controller in addition an ANN based intelligent single MPPT control algorithm is proposed to pull out MPP from the high penetrating hybrid RES system concomitantly.

III. SYSTEM DESIGN

A new PEC topology of SEPIC converter is proposed for integration of solar and WECS sources and to make a hybrid RES. The schematic diagram of a proposed hybrid system with SEPIC converter is illustrated in Fig. 3.1. The proposed SEPIC converter is formed by rearranging the diodes D1 and D2 in the cuk and SEPIC converters and by sharing the output inductor SEPIC converter. The pro of the proposed converter is to eradicate the need of input filters to lessen the high frequency harmonics and it will function in both individual and concurrent modes of operation. The most important pro of the proposed system is when one source isn't accessible the other source will supply the essential power to meet the demand. Even under randomly available both sources the net output voltage of the hybrid RES system is the summation of PV and wind system voltages. SEPIC converter is a 3 port DC-DC step up or else step down converter, the primary port is provided thru a SEPIC converter for linking PV source and the subsequent port is by SEPIC converter for linking rectified output of the wind system and lastly third port is the output port for linking load across it.

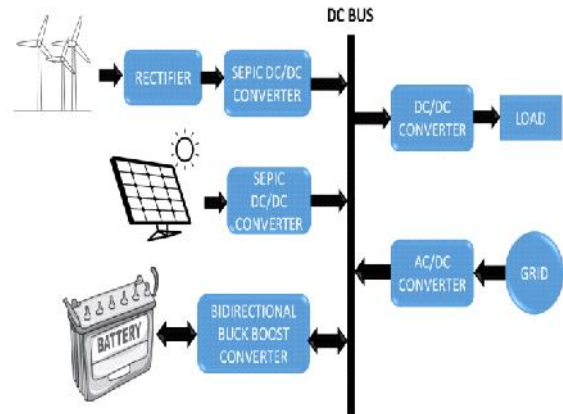

Figure 3 Proposed SEPIC converter based RES

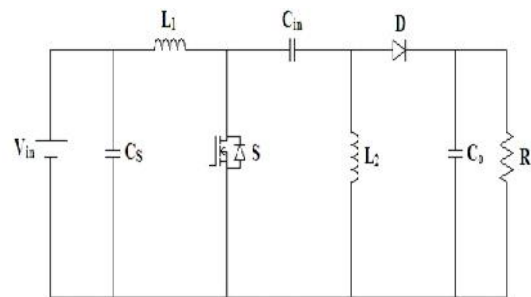
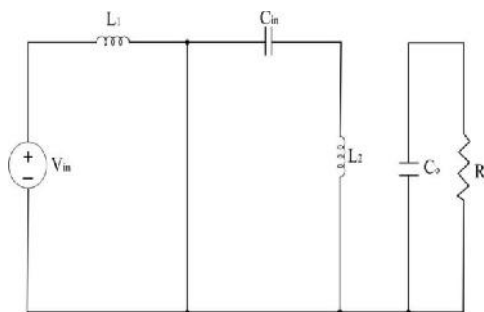

Figure 4 Proposed SEPIC Converter Topology

The proposed HCS converter operates in four different modes based on the availability of solar irradiation level and wind velocity, the operation of the HCS converter depends on the control switches S1 and S2. It operates ON/OFF states based on the availability of the RES input data and each mode of operation is described as following section.

IV. RESULT AND DISCUSSION

In Mode-I, both PV and WECS together generate power to meet the demand. The control switches of both PV and wind are in operating state. The equivalent circuit of Mode-1 with different power converter switches is illustrated in Fig. 5. In this mode, the diodes D1 and D2 are in reverse bias condition, during the period 0 to t1, inductor L1 is charged by PV source and for period 0 to t2, inductor L3 is charged by the wind source and the energy stored in the capacitor C1 and C3 starts discharging to the DC link capacitor through the sharing inductor L2.



$$I_{L1} = I_{PV} + \frac{V_{PV}}{L_1}t$$

$$I_{L2} = I_{dc} + \frac{(V_{c1} + V_{c3})}{L_2}t$$

$$I_{L3} = I_W + \frac{V_W}{L3}t$$

Figure 5 Switch on condition

In Mode-II, PV system generates power to overcome the demand. The control switch of PV source is in operating state. The equivalent circuit of mode-II with different power converter switches is shown in Fig. 6. In this mode, the diodes D1 is reverse biased and D2 is forward biased, during the period 0 to t1, inductor L1 is charged by PV source, the capacitors C1 starts discharging the stored energy to the sharing inductor L2 and the diode D2 provides the closed path to discharge the stored energy in L3 and C3 to the Capacitor C2.

$$I_{L1} = I_{PV} + \frac{V_{PV}}{L1}t$$

$$I_{L2} = I_{dc} + \frac{V_{C1}}{L2}t$$

$$I_{L3} = I_w + \frac{(V_w - V_{C3})}{L3}t$$

Figure 6 Switch off condition

The proposed sepic power converter topologies are presented in this chapter. The proposed converter topologies are designed by rearranging and sharing the converter components between the converters to make a hybrid multi input power converters with less number of power converter components and to reduce the switching stress of the converter. The developed sepic converter gives the efficiency of 90.8 % by operating at duty cycle 0.895, whereas existing converter gives 89.1 % with duty cycle 0.82. From this analysis, sepic converter gives the higher efficiency compared to HCS converter, but with respective to duty cycle, HCS converter operates with less duty cycle compared to the HL converter.

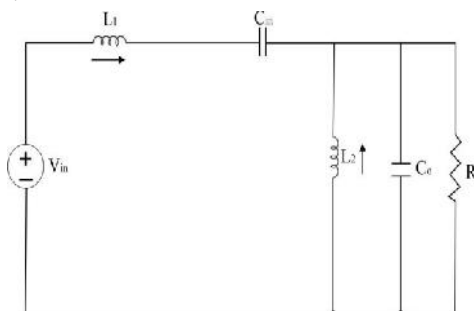

The performance analysis of the developed hybrid converter are validated with the proposed single MPPT control

algorithms using MATLAB/Simulink software. From the literature, the availability of both PV and WECS sources are alternative to each other and to check the feasibility of the developed converter operation in both individual and simultaneous modes, the availability of the RES are taken as follows, for the period 0 to 0.5 sec, the availability of wind source is maximum of 12 m/s and the PV irradiation is 600 W/m². Similarly, for a period of 0.5 to 1 sec and 1 to 1.5 sec, wind velocity is 10 m/s with PV irradiation of 800 W/m² and velocity of wind is 8 m/s with PV irradiation of 1000 W/m² respectively as illustrated in Fig. 7 The simulation output of 560 W PV system output voltage, current, and power is illustrated in Fig. 5.2 and the simulation output of 500 W wind energy conversion system output voltage, current, and power is illustrated in Fig. 8.

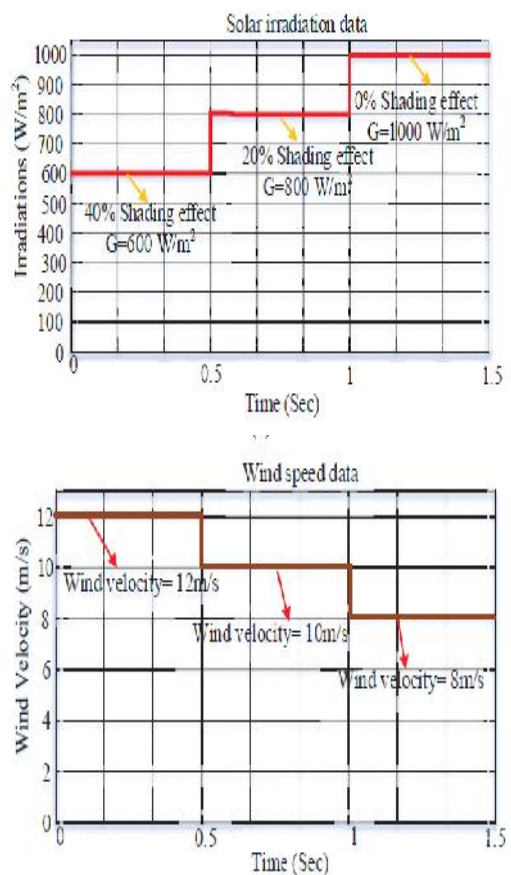

Fig. 7 Input Solar Irradiation Data and Input Wind Speed Data

The effectiveness of the proposed hybrid solar and wind system with the developed sepic converters and the proposed single MPPT controllers are evaluated in both SA and GC modes under three different time sections, based on the availability of the input sources data as considered.

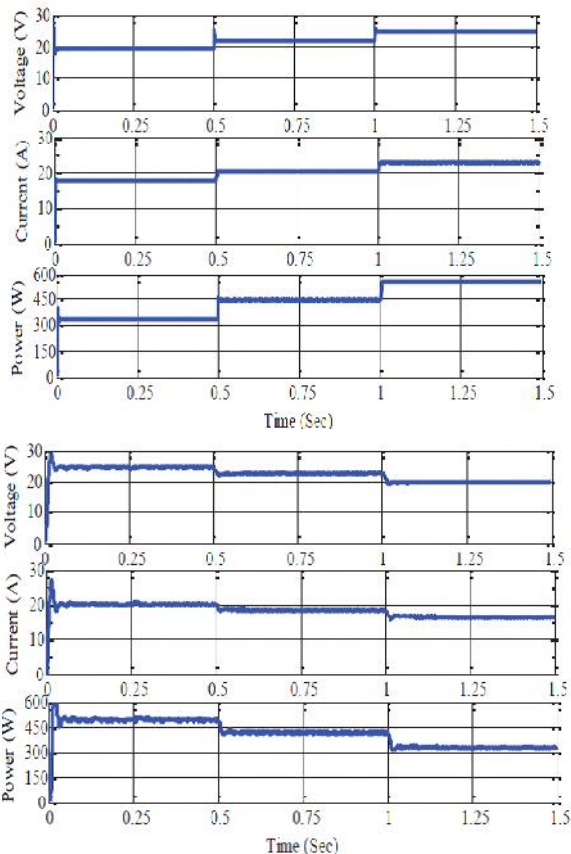

Fig. 8 560 W PV and wind energy system output Voltage, Current, and Power

To assess the proposed converter, a model is developed and analysed in the matlab system. The obtained results are measured using the mixed signal oscilloscope (MSO). The PV output power of the proposed converter configuration is presented in Fig.8. To evaluate the effectiveness of the proposed system under non-linear characteristic, a step change in irradiation and wind speed is considered in proposed system. It is observed that based on the PV irradiation, the RBFN based MPPT controller gives the maximum power. To analyze the feasibility of the converter and the effectiveness of maximum power tracking, three different time sections are considered by assuming different solar irradiance and wind speed input data. The performance is analyzed for grid connected mode, by considering the different load conditions and the load sharing between the renewable energy sources and grid are presented.

V. CONCLUSION

The performance analysis has been carried out based on two hybrid DC-DC converters and two single MPPT controllers in both SA and GC modes. The performance analysis is carried out by designing a hybrid PV and WECS system with the sepic converters along with the proposed

single MPPT controllers, under three different time sections based on considered solar and wind input data. The performance analysis has been carried out in grid connected mode, by considering the three different load conditions and the load sharing between the renewable energy sources and grid are presented. The developed sepic converters have been connected to the hybrid solar and wind systems with the proposed single MPPT controllers. The performance analysis has been carried out based on availability of PV and wind input data, under three different time sections for both modes. From the analysis, it is observed that developed sepic converter with RBFN based intelligent single MPPT controller provides the better results. A hybrid DC-DC power converter is derived by sharing the PEC components between the converters and a single intelligent MPPT controllers are proposed to obtain MPP from both PV and WECS sources concurrently.

The below mentioned phrases represent futuristic scopes in this field.

- A coordinated multi input hybrid converter (DC-DC-AC) could be amended for the hybrid system.
- Coordinated MPPT with energy management system could be proposed for the hybrid renewable energy system.
- The proposed hybrid converters could be integrated with different renewable energy sources combinations.

REFERENCES

- [1] Bae, S. and Kwasinski, A. (2012), 'Dynamic modeling and operation strategy for a microgrid with wind and photovoltaic resources', *IEEE Transactions on smart grid* 3(4), 1867–1876.
- [2] Bayrak, G. and Cebeci, M. (2014), 'Grid connected fuel cell and pv hybrid power generating system design with matlab simulink', *International journal of hydrogen energy* 39(16), 8803–8812.
- [3] Chen, C.-W., Liao, C.-Y., Chen, K.-H. and Chen, Y.-M. (2015), 'Modeling and controller design of a semiisolated multiinput converter for a hybrid pv/wind power charger system', *IEEE Transactions on Power Electronics* 30(9), 4843–4853.
- [4] Duflo-López, R., Bernal-Agustín, J. L. and Mendoza, F. (2009), 'Design and economical analysis of hybrid pv-wind systems connected to the grid for the intermittent production of hydrogen', *Energy Policy* 37(8), 3082–3095.
- [5] Hintz, A., Prasanna, U. R. and Rajashekara, K. (2015), 'Novel modular multiple-input bidirectional dc-dc power

- converter (mipc) for hev/fcv application', IEEE Transactions on Industrial Electronics 62(5), 3163–3172.
- [6] Jiang, W. and Fahimi, B. (2009), Multi-port power electric interface for renewable energy sources, in 'Applied Power Electronics Conference and Exposition, 2009. APEC 2009. Twenty-Fourth Annual IEEE', IEEE, pp. 347–352.
- [7] Kumaravel, S. and Ashok, S. (2011), Design and analysis of multiple input power conditioner for solar pv/wind hybrid energy system, in 'TENCON 2011-2011 IEEE Region 10 Conference', IEEE, pp. 883–887.
- [8] Li, Y., Ruan, X., Yang, D., Liu, F. and Chi, K. T. (2010), 'Synthesis of multiple-input dc/dc converters', IEEE Transactions on Power Electronics 25(9), 2372–2385.
- [9] Tiwari, R. and Babu, N. R. (2016), 'Recent developments of control strategies for wind energy conversion system', *Renewable and Sustainable Energy Reviews* 66, 268–285.
- [10] Hirose, T. and Matsuo, H. (2012), 'Standalone hybrid wind-solar power generation system applying dump power control without dump load', IEEE transactions on industrial electronics 59(2), 988–997.
- [11] Ram, J. P., Rajasekar, N. and Miyatake, M. (2017), 'Design and overview of maximum power point tracking techniques in wind and solar photovoltaic systems: A review', *Renewable and Sustainable Energy Reviews* 73, 1138–1159.