

Design of Smart Blind Stick

G.S. Gokul¹, N. Harish², D. Praveen³, Devesh Rahul⁴

^{1, 2, 3, 4} Dept of Electronics and communication

^{1, 2, 3, 4} S.R.M. Institute of Science and Technology, Ramapuram, Chennai, India

Abstract- The Blindness is frequently used to describe severe visual impairments with or without residual vision. The application of ultrasonic ranging scheme for producing electronic walking stick for the blind is a technological advancement. There is a great dependency for any type of movement or walking within area or out of the particular area, they use only their natural senses such as touch or sound for identification or walking. To overcome all these problems of blind people, we are developing a project by using simple available technologies. This walking stick for blind people has multiple sensors, with the help of which it has been possible to enhance more features to the walking stick. The features are to detect the obstacle for collision avoidance, it detects the object in directions up, down and front. The other sensor placed near bottom tip of the walking cane to find the pits on the ground. We integrate these sensors to the voice record and play chip. In this project, sensors play a key role to detect the objects in all directions and thus help blind people to be independent.

Keywords- Residual vision, Sensors, Play chip, Voice record

I. INTRODUCTION

This project proposes to design and develop a portable unit (stick) for them for easy usage and navigation in public places. The blind stick is integrated with ultrasonic sensor along with light and water sensing. Our proposed project first uses ultrasonic sensors to detect obstacles ahead using ultrasonic waves. On sensing obstacles the sensor passes this data to the microcontroller. The microcontroller then processes this data and calculates if the obstacle is close enough. If the obstacle is not that close the circuit does nothing. If the obstacle is close the microcontroller sends a signal to sound a buzzer. It also detects and sounds a different buzzer if it detects water and alerts the blind. One more feature is that it allows the blind to detect if there is light or darkness in the room. A wireless RF based remote is used for this purpose. Pressing the remote button sounds a buzzer on the stick which helps the blind person to find their stick. Thus this system allows for obstacle detection as well as finding stick if misplaced by visually disabled person.

II. COMPONENTS

2.1 Arduino-nano:

Arduino-nano is a **ATmega328 based small and breadboard compatible arduino board**. It has mostly same functionality to Arduino Uno but without DC power jack and works with a mini-B USB cable instead of standard one.

2.2 HC- SR04 PINOUT:

It is an ultrasonic sensor, also known as an ultrasonic transducer that is based on a transmitter and receiver and mainly used to determine the distance from the target object.

The amount of time it takes to send and receive waves will determine how far the object is placed from the sensor. It mainly depends on the sound waves working on “non-contact” technology. The required distance of the target object is measured without any damage, giving you accurate and precise details. This sensor comes with a range between 2cm to 400cm and is used in a wide range of applications including speed and direction measurement, wireless charging, humidifiers, medical ultrasonography, sonar, burglar alarms, and non-destructive testing.

2.3 LDR

A **Light Dependent Resistor** (also known as a photoresistor or LDR) is a device whose resistivity is a function of the incident electromagnetic radiation. Hence, they are light-sensitive devices. They are also called as photoconductors, photoconductive cells or simply photocells.

They are made up of semiconductor materials that have high resistance. There are many different symbols used to indicate a photoresistor or LDR, one of the most commonly used symbol is shown in the figure below. The arrow indicates light falling on it.

2.4 LM7805:

Voltage sources in a circuit may have fluctuations resulting in not providing fixed voltage outputs. A voltage regulator IC maintains the output voltage at a constant value. 7805 IC, a member of 78xx series of fixed linear voltage regulators used to maintain such fluctuations, is a popular voltage regulator integrated circuit (IC). The xx in 78xx indicates the output voltage it provides. 7805 IC provides +5

volts regulated power supply with provisions to add a heat sink.

2.5 433MHz RF Tx-Rx:

This little module is a transmitter among two. It is really simple as it looks. The heart of the module is the SAW resonator which is tuned for 433.xx MHz operation. There is a switching transistor and a few passive components, that's it. When a logic HIGH is applied to the DATA input, the oscillator runs producing a constant RF output carrier wave at 433.xx MHz and when the DATA input is taken to logic LOW, the oscillator stops. This technique is known as Amplitude Shift Keying, which we will discuss in detail shortly.

III. LITERATURE REVIEW

S.Gangwar(2011) designed a smart stick for blind which can give early warning of an obstacle using Infrared (IR) sensors. After identifying the obstacles, the stick alerts the visually impaired people using vibration signals.

S.Chew(2012) proposed the smart white cane, called Blind spot that combines GPS technology, social networking and ultrasonic sensors to help visually impaired people to navigate public spaces.

Benjamin etal(2011) had developed a smart stick using laser sensors to detect the obstacles and down curbs . Obstacle detection was signaled by a high pitch BEEP using a microphone.

Central Michigan University (2009) developed an electronic cane for blind people that would provide contextual information on the environment around the user.

Mohd Helmyabd Wahab and Amirul A. Talibetal (2011) developed a cane could communicate with users through voice alert and vibration signal) . Ultrasonic sensors are used to detect obstacle in front, since ultrasonic sensors are good in detecting obstacle in few meters range and this information will be sent in the form of voice signal. This voice signal is send via speaker to the user.

Alejandro R. Garcia Ramirez and Renato Fonseca Livramento da Silvaetal (2012) designed an assistive technology device called the electronic long cane to serve as a mobility aid for blind and visually impaired people .The author implements the cane with an ergonomic design and an embedded electronic system, which fits inside the handle of a traditional long cane. The system was designed using haptic sensors to detect obstacles above the waistline.

Joao José, Miguel Farrajota, Joao M.F. Rodrigues (2011) designed a smart stick prototype. It was small in size, cheap and easily wearable navigation aid. This blind stick functions by addressing the global navigation for guiding the user to some destiny and local navigation for negotiating paths, sidewalks and corridors, even with avoidance of static as well as moving obstacles .

Shruti Dambhare and A.Sakhare (2011) designed an artificial vision and object detection with real-time assistance via GPS to provide a low cost and efficient navigation aid for blind which gives a sense of artificial vision by providing information about the environmental scenario of static and dynamic objects around them.

IV. ARDUINO CODE

```
const int trigger = 3; //Trigger pin of 1st Sesnor
const int echo = 2; //Echo pin of 1st Sesnor
const int Buzz = 13; //Echo pin of 1st Sesnor
const int Remote = A0; //Echo pin of 1st Sesnor
const int Light = A1; //Echo pin of 1st Sesnor
long time_taken;
int dist;
int Signal;
int Intens;
int similar_count;
void setup() {
  Serial.begin(9600);
  pinMode(Buzz,OUTPUT);
  digitalWrite(Buzz,LOW);
  pinMode(trigger, OUTPUT);
  pinMode(echo, INPUT);
}
/*###Function to calculate distance###*/
void calculate_distance(int trigger, int echo)
{
  digitalWrite(trigger, LOW);
  delayMicroseconds(2);
  digitalWrite(trigger, HIGH);
  delayMicroseconds(10);
  digitalWrite(trigger, LOW);
  time_taken = pulseIn(echo, HIGH);
  dist= time_taken*0.034/2;
  if (dist>300)
  dist=300;
}
void loop() { //infinite loopy
  calculate_distance(trigger,echo);
  Signal = analogRead(Remote);
  Intens = analogRead(Light);
  //Check if Remote is pressed
```

```

int temp = analogRead(Remote);
similar_count=0;
while (Signal==temp)
{
  Signal = analogRead(Remote);
  similar_count++;
}
//If remote pressed
if (similar_count<100)
{
  Serial.print(similar_count); Serial.println("Remote Pressed");
  digitalWrite(Buzz,HIGH);delay(3000);digitalWrite(Buzz,LOW);
}
//If very dark
if (Intens<200)
{
  Serial.print(Intens); Serial.println("Bright Light");
  digitalWrite(Buzz,HIGH);delay(200);digitalWrite(Buzz,LOW);
  delay(200);digitalWrite(Buzz,HIGH);delay(200);
  digitalWrite(Buzz,LOW);delay(200);
  delay(500);
}
//If very bright
if (Intens>800)
{
  Serial.print(Intens); Serial.println("Low Light");
}

digitalWrite(Buzz,HIGH);delay(500);digitalWrite(Buzz,LOW);
delay(500);digitalWrite(Buzz,HIGH);delay(500);
digitalWrite(Buzz,LOW);delay(500);
}
if (dist<50)
{
  Serial.print(dist); Serial.println("Object Alert");
  digitalWrite(Buzz,HIGH);
  for (int i=dist; i>0; i--)
    delay(10);
  digitalWrite(Buzz,LOW);
  for (int i=dist; i>0; i--)
    delay(10);
}
//Serial.print("dist=");
//Serial.println(dist);
//Serial.print("Similar_count=");
//Serial.println(similar_count);
//Serial.print("Intens=");
//Serial.println(Intens);
}
    
```

V. SCHEMATIC CIRCUIT DIAGRAM

5.1 RF Receiver:

This **Arduino Smart Blind Stick Project** requires two separate circuits. One is the main circuit which will be mounted on the blind man’s stick. The other is a small remote **RF transmitter circuit** which will be used to locate the main circuit.

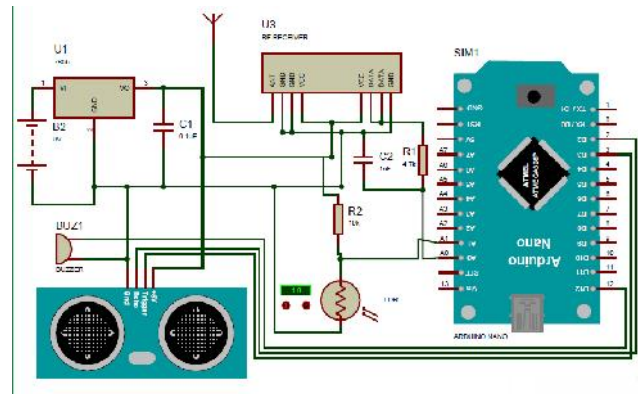

As we can see an **Arduino Nano** is used to control all the sensors. The complete board is powered by a 9V battery which is regulated to +5V using a 7805 Voltage regulator.

The **Ultrasonic sensor** is powered by 5V and the trigger and Echo pin is connected to Arduino nano pin 3 and 2 as shown above. The **LDR** is connected with a resistor of value 10K to form a Potential divider and the difference in voltage is read by Arduino ADC pin A1. The ADC pin A0 is used to read the signal from **RF receiver**. The output of the board is given by the **Buzzer** which is connected to pin 12.

5.2 RF Transmeter:

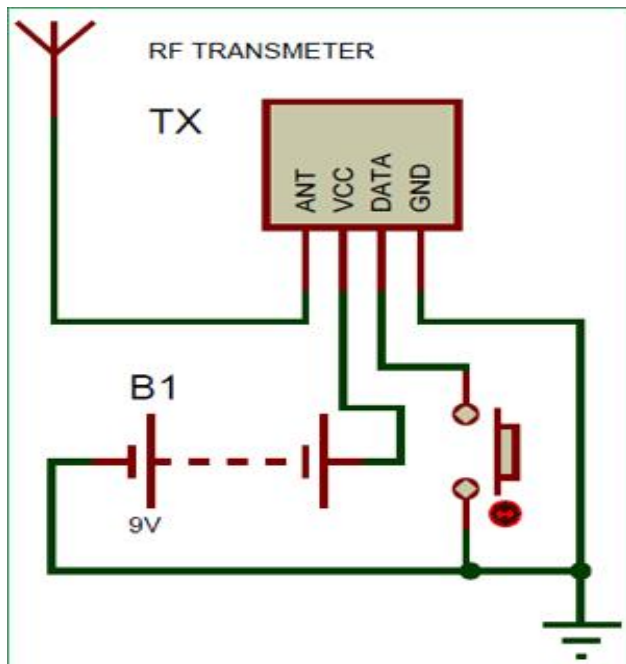

We have used a small hack to make this RF remote control circuit to work. Normally while using this 433 MHz module requires an Encoder and Decoder or two MCU to work. But, in our application we just need the receiver to detect if the transmitter is sending some signals. So the Data pin of the transmitter is connected to Ground or Vcc of the supply.

The data pin of the receiver is passed through an RC filter and then given to the Arduino as shown below. Now, whenever the button is pressed the Receiver output some constant ADC value repeatedly. This repetition cannot be observed when the button is not pressed. So we write the Arduino program to check for repeated values to detect if the button is pressed. So that is how a Blind person can track his stick.

VI. RESULT AND DISCUSSION

As ultrasonic sensors work on principle of echo, studying of its reflection on different obstacle is very important. The measurement cycle starts with microcontroller transmitting the 10 μ s high level pulse to the sensor trigger pin to start ranging (T1), then the sensor will send out ultrasonic signal with 40 kHz and 450 μ s (T2) and then wait to capture the rising edge output by echo port (T3) from 150 μ s: 25ms, depending on measured distance as shown in figure 9. In case of no obstacle (no signal reflected) it waits 38ms before it restarts transmission. Ultrasonic distance sensor uses time of flight (TOF) to detect obstacle - the output is a digital pulse which length is the time it takes for the sound to reach the target and return before the beep is heard. The device was accurate with detecting obstacle of up to 2m. The water

detector which is made up of two wires that which when came in contact with water would beep. They had to be touching the water before they are able to detect the water, which is why they were placed underneath the stick. It is worth mentioning at this point that the aim of this study which is the design and implementation of a smart walking stick for the blind has been fully achieved. The Smart Stick acts as a basic platform for the coming generation of more aiding devices to help the visually impaired to navigate safely both indoor and outdoor. It is effective and affordable. It leads to good results in detecting the obstacles on the path of the user in a range of three meters. This system offers a low-cost, reliable, portable, low power consumption and robust solution for navigation with obvious short response time.

VII. CONCLUSION

Our aim is to make the world a better living environment for people who are handicapped or have a tough time seeing. From the results seen above, it is clear that the user can greatly benefit in terms of knowing what is around them at a cheaper, efficient and easy way. There are wide varieties of objects that the device can detect. Hence it can be used for everyday activities to enhance their experience and create a better place for them. In the future, face detection can be added, so that if there are any familiar faces, they can be recognized. Also text conversions would help the users read books or posters and signs to enhance their understanding even more. With increasing research in embedded systems, more computation in a smaller scale can be expected in the future.

REFERENCES

- [1] WHO, "Universal eye health: a global action plan 2014-2019", ISBNNo: 978 92 4 150656 4.
- [2] Dominic Basulto, "Artificial intelligence is the next big tech trend.", Washington Post, March 25, 2014
- [3] Joseph Redmon, Santosh Divvala, Ross Girshick, Ali Farhadi, "You Only Look Once: Unified, Real-Time Object Detection", Conference on Computer Vision and Pattern Recognition 2016, arXiv:1506.02640
- [4] Dionisi, A & Sardini, Emilio & Serpelloni, Mauro. (2012). "Wearable object detection system for the blind". 2012 IEEE I2MTC - International Instrumentation and Measurement Technology Conference, Proceedings. 1255-1258. 10.1109/I2MTC.2012.6229180.
- [5] Nada, Ayat & Mashali, Samia & Fakhr, Mahmoud & Seddik, Ahmed. (2015). "Effective Fast Response Smart Stick for Blind People". 10.15224/978-1-63248-043-9-29.
- [6] M.Everingham, S.M.A.Eslami, L.Van Gool, C.K.I.Williams, J.Winn, and A.Zisserman. The pascal

visual object classes challenge: A retrospective. *International Journal of Computer Vision*, 111(1):98–136, Jan. 2015.

- [7] L. Chen, J. Su, M. Chen, W. Chang, C. Yang and C. Sie, "An Implementation of an Intelligent Assistance System for Visually Impaired/Blind People," 2019 IEEE International Conference on Consumer Electronics (ICCE), Las Vegas, NV, USA, pp. 1-2, 2019.
- [8] N. Dey, A. Paul, P. Ghosh, C. Mukherjee, R. De and S. Dey, "Ultrasonic Sensor Based Smart Blind Stick," 2018 International Conference on Current Trends towards Converging Technologies (ICCTCT), Coimbatore, pp. 1-4, 2018.
- [9] Shaha, S. Rewari and S. Gunasekharan, "SWSVIP-Smart Walking Stick for the Visually Impaired People using Low Latency Communication," 2018 International Conference on Smart City and Emerging Technology (ICSCET), Mumbai, pp. 1-5, 2018.