

# Computational Fluid Dynamics And Analysis of Micro Channel Heat Pump

G. Balaji<sup>1</sup>, B. Malsoor<sup>2</sup>

<sup>1,2</sup> Asso. Professor, Dept of Mechanical

**Abstract-** Study water flow and heat transfer characteristics in a three-dimensional straight micro channel heat sink of rectangular cross-section to be performed by analytical and CFD software. A three-dimensional model was built, to investigate the conjugate fluid flow and heat transfer phenomena in a copper based micro channel heat sink. In simulation studied the effect of aspect ratio on parameters like heat transfer Coefficient, average temperature, internal heat generation and pressure drop. Corresponding to this, analysis is also undergoing with varying flow rate and heat flux. Then compare the results obtained from analytical and CFD simulation, using these results will have the suitable micro channel cross-section for dissipation of heat.

**Keywords-** Aspect Ratio, Computational Fluid Dynamics, Heat Sink, Heat Transfer, Micro channel.

## I. INTRODUCTION

As the electronics equipment becomes more advanced and smaller in size, it faces thermal engineering challenges from the high level of heat generation and the reduction of available surface area for heat removal. In the absence of sufficient heat removal, the working temperature of this component may exceed a desired temperature level which then increases the critical failure rate of equipment. Therefore, advanced electronic equipment with high heat generation requires an efficient and compact cooling device to provide system operation.

In order to meet the cooling requirement, one need to increase the product of heat transfer coefficient(h) and heat transfer surface area (A). Since heat transfer coefficient is related to the channel hydraulic diameter. The heat transfer surface area can be increased by incorporating micro channels on the chip surface. Micro channel width, thickness and channel height such a parameters affects the performance of the heat sink. Direct chip cooling with micro channels is a good solution for cooling of such kinds of devices. These chips have machined micro channels through which cooling fluid like water is circulated. The cooling liquid removes heat by single phase forced convection. Flow within the micro channel is considered as fully developed laminar flow with

constant heat flux and constant temperature boundary conditions.

Due to higher densities associated with liquids, the use of forced liquid cooling can reach heat transfer rates an order of magnitude greater than when gaseous fluids such as air is used. A coolant liquid is circulated through a flow circuit consisting of a light duty electric pump, a heat exchanger extracting heat from the heated device, a heat exchanger expelling heat to the surroundings, a liquid reservoir and a filter. [4, 5] Recent advances in pumped-liquid cooling system technology represent a promising alternative for cooling high power density processors. Micro channel cooling is the alternative to conventional channel.

### 1.1. Classification of Channels

On the basis of hydraulic diameter the channels are classified by following scheme as shown in Table 1.1.

The channels are classified from conventional channel to molecular nano channels.

**Table 1.1** Classification Scheme of channels

Conventional channels	$D_h > 3\text{mm}$
Minichannels	$3\text{mm} \geq D_h > 500\ \mu\text{m}$
Microchannels.	$500\ \mu\text{m} \geq D_h > 10\ \mu\text{m}$
Transitional Micro channels	$10\ \mu\text{m} \geq D_h > 1\ \mu\text{m}$
of channels	
Transitional Nanochannels	$1\ \mu\text{m} \geq D_h > 0.1\ \mu\text{m}$
Molecular Nanochannels	$0.1\ \mu\text{m} \geq D_h$

### 1.2. Working Principle

Fig.1.1 and 1.2 gives the overview of the use of the microchannel heat sink to dissipate the heat from the source. Basically, the working fluid is forced through the micro channels built on a plate attached to an electronic device (heat source) to carry away the heat generated by the electronic device. Micro channel heat sink is built with a very high

aspect ratio (height/width) to increase the total surface area. As the fluid flows through the micro channels, their large surface area enables them to cool hot spots with heat flux as high as  $1000 \text{ W/cm}^2$ .

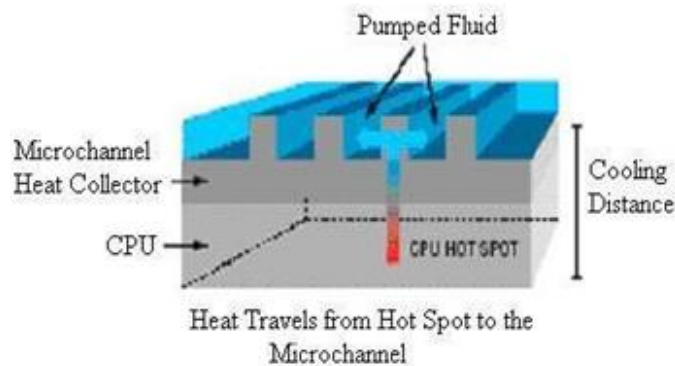

**Figure 1.1** Microchannels etched to heat source heat sink.

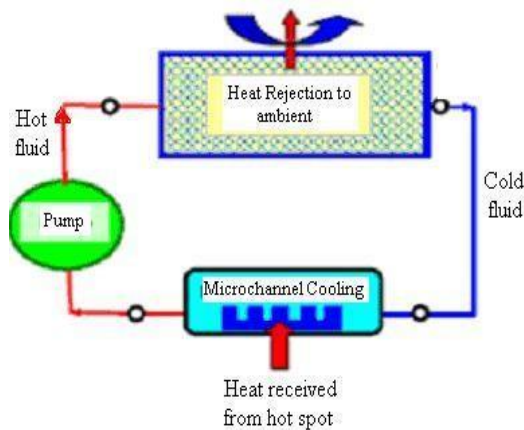

## II. INTRODUCTION

analysis reported here is conducted using a commercial general purpose CFD software package FLUENT 6.3.26 [8], which solves the three-dimensional form of mass, momentum, and energy equations. The problem under consideration is a conjugate heat transfer problem which involves heat transfer in both solid and liquid. The CFD calculation of the entire heat sink with 100 channels is very intensive and time consuming. Since all the channels are geometrically identical and receive the same flow rate and heat flux, calculation domain can be restricted to only one channel.

*Following assumptions are made for CFD simulation*

- Flow within the channel is laminar.
- Flow is fully developed.
- Neglect the thermal entry length.
- Top of the channel is adiabatic.

- Side wall of the channel are adiabatic, also.

## 2.2 Methodology of CFD Simulation

### 2.1.1. Pre Processor

Pre-processing consists of the input of a flow problem to a CFD program by means of an operator- friendly interface and the subsequent transformation of this input into a form suitable for use by the solver. The solution to a flow problem is defined at nodes inside each cell. The accuracy of a solution is governed by the number of cell in the grid. The accuracy of a CFD solution is governed by the number of cells in the grid.

### 2.1.2. Solver

Two solvers are available in the fluent, the pressure based solver and density based solver. The pressure based solver is used for the analysis of the microchannel heat sink.

### Pressure Based Solver

The pressure-based solver uses a solution algorithm where the governing equations are solved sequentially. Because the governing equations are non-linear and coupled, the solution loop must be carried out iteratively in order to obtain a converged numerical solution. In the pressure-based algorithm, the individual governing equations for the solution variables are solved one after another. Each governing equation, while being solved, is "decoupled" or "segregated" from other equations. The pressure-based algorithm is memory- efficient, since the discretized equations need only be stored in the memory one at a time. However, the solution convergence is relatively slow, as much as the equations are solved in a decoupled manner.

### Algorithm

Solving conjugate heat transfer problem, the Pressure-Implicit with Splitting of Operators (PISO) algorithm is used. The PISO pressure-velocity coupling scheme, part of the SIMPLE family of algorithms, is based on the higher degree of the approximate relation between the corrections for pressure and velocity. [8]

### 2.1.3. Post Processing

The visualization of the obtained results from the analysis is done in the post processing. The vector plot, contours plot, X-Y plots, temperature distribution, pressure distribution are obtained in the post processing.

2.1.4.

The 3-D model of the microchannel heat sink is developed in a commercial general purpose software GAMBIT (Geometry and Mesh Building Intelligent Tool) 2.3.16 [8]. The geometry of the microchannel and flow domain in the microchannel are created by the scheme converting lower topology to higher topology means first creating the vertex, then edges, then faces and then volume. Fig. 2.1 shows the created geometry of the microchannel heat sink using GAMBIT.

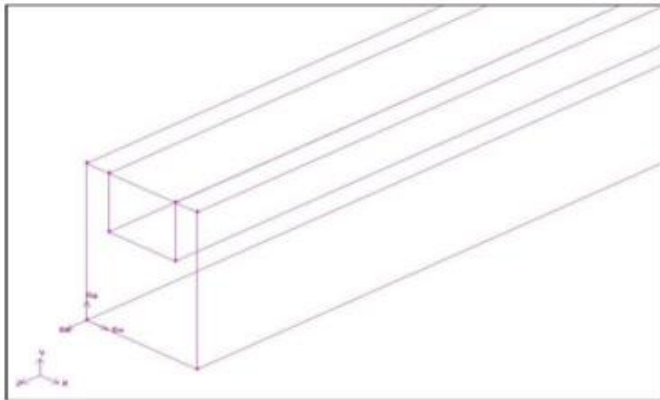

Figure 2.1 Geometry of the microchannel

Mesh Generation

The GAMBIT has the facility to generate the meshing simultaneously with the geometry creation [8]. The second step is the discretization of the physical system which divides the geometry into the number of finite volumes, called grid generation or meshing. The structured grid is used for discretization of microchannel geometry. The features of the structured grid are each grid points have fixed number of neighbors and each cell is quadrilateral in shape. The domain must have quadrilateral topology. Number of grid points cannot be changed in the region where there is rapid change the field properties. The entire strip lying between two grid lines must be made dense.

Figure 2.2 and 2.3 shows the meshing of the microchannel domain and water domain developed in general purpose software GAMBIT 2.3.16.

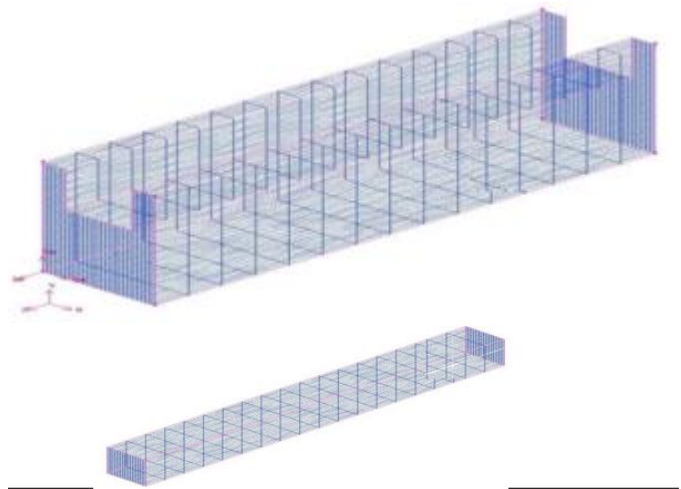

Figure 2.2 Meshing of the channel domain

2.1.5. Grid Independence Study

The size of the element used for meshing of the physical domain is affecting the analysis results. Accuracy of the analysis results are depends upon the size of the element used for meshing meanwhile the total element used for the meshing scheme. By trial and error method, selecting the meshing scheme for microchannel heat sink. Table 2.3 shows the total number of element used for analysis of microchannel heat sink with result of average base temperature.

Table 2.3 Meshing scheme of the microchannel heat sink

Number of Element	Average Base Temperature (K)
100000	309
130000	309.59
150000	309.998
170000	310.023
200000	310.52
250000	311.023
300000	311.023

The total number of element increases above 2,50,000, there have no change in the results. But selection of the number of elements are depends upon the microchannel geometry. So, for every geometry configuration of the microchannel heat sink, above 2,50,000 total number of element are used.

III. PARAMETRIC ANALYSIS OF MICROCHANNEL HEAT SINK

Parametric analysis of microchannel heat sink is carried out by using CFD software and analytical method. Two different flow constraints are analyzed separately with same constant heat flux boundary condition and coolant. The parameters like aspect ratio ( $\alpha$ ), fin thickness to fin width ratio ( $\beta$ ) and width ( $C_w$ ) are varied and performance is measured for

total thermal resistance of the heat sink. Figure 3.1, 3.2 and 3.3 shows that the effect of the aspect ratio on the internal heat generation ( $Q_{int}$ ), heat transfer coefficient, average base temperature and pressure drop. Plot shows that decrement in the internal heat generation and heat transfer coefficient is increase with the increasing aspect ratio. Its effects on base temperature achieve lower value as shown in the Fig. 3.2 and ultimately decreasing the total thermal resistance. Hence, there is no optimum value of aspect ratio for optimize the thermal resistance.

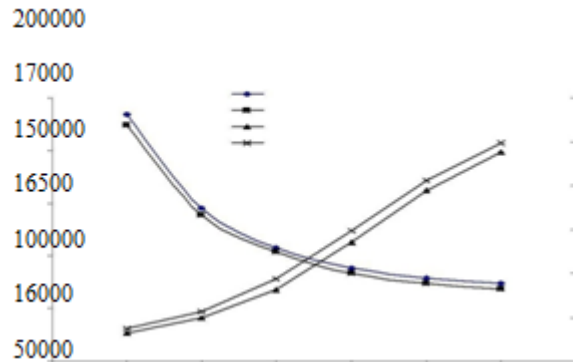

Lower pressure drop is desirable for microchannel heat sink design. Results have been obtained for heat flux 60W/cm<sup>2</sup> and 80W/cm<sup>2</sup>. Same geometrical configuration with identical boundary conditions, the maximum allowable temperature in the system goes to 63°C. So, same heat sink is used for 60W/cm<sup>2</sup> and 80W/cm<sup>2</sup> heat source. Pressure drop are not affected with heat flux of 60W/cm<sup>2</sup> and 80W/cm<sup>2</sup>.

### 3.1. Concluding Remarks

Obtained CFD and analytical results are shows close agreement with the results available in the literature. After defining and validating methodology, parametric analysis is carried out. The plots of internal heat generation ( $Q_{int}$ ), heat transfer coefficient, average base temperature and pressure drop with varying parameters like aspect ratio. Obtained CFD results are validate with the results obtained analytically. CFD simulation is carried out for varying base thickness, changing the material of the microchannel heat sink. Analysis is carried out for changing water inlet temperature, also. Two thermal boundary conditions are simulating like constant heat flux and constant channel wall temperature.

1. Aspect Ratio should be set as high as possible to reduce total thermal resistance in constant mass flow rate flow constraints. There will be no optimum value of aspect ratio for minimum thermal resistance. But in constant

pressure drop flow constraint, beyond aspect ratio 4, there is no any change in results. Optimum value of aspect ratio for constant drop flow constraints is 4.

2. Low fin thickness to channel width ratio is required for both constant mass flow rate and constant pressure drop conditions.
3. Increasing channel width for constant mass flow rate, increases thermal resistance. So, narrow channel is preferable for constant mass flow rate constraints.
4. In constant pressure drop condition, increasing width decreases the thermal resistance. Optimum value of the width is 200  $\mu$ m for constant pressure drop flow constraint.

### REFERENCES

- [1] D. B. Tuckerman and R. F. W. Pease, High-performance heat sinking for VLSI, *IEEE Electron Device Letter*, 2(5), May (1981), pp. 126–129.
- [2] S.G. Kandlikar, W.J. Grande. (2004), Evaluation of single phase flow in microchannels for high heat flux chip cooling thermohydraulic performance enhancement and fabrication technology, *Heat Transfer Eng*, 25(8), pp. 5–16. Shekhar Dinkar Thakre, Jayashree P. Zope, Nilima A. Bachchuwar and Sourabh S. Kulkarni
- [3] C. B. Sobhan and S.V. Garimella, A comparative analysis of studies on heat transfer and fluid flow in microchannels, *Microscale Thermophysical Eng*. 5, (2001), pp. 293–311.
- [4] P.S. Lee and S.V. Garimella, Thermally developing flow and heat transfer in rectangular microchannels of different aspect ratios, *Int. J. Heat Mass Transf.* 49, (2006), pp. 3060–3067.
- [5] Ngoclan Tran, Chunping Zhang, Thantrung Dang, Numerical and Experimental Studies on Pressure Drop and Performance Index of an Aluminum Microchannel Heat Sink, *IEEE Computer Society Washington, DC, USA, IS3C '12*, (2012), pp. 252–257.
- [6] V. V. Dharaiya and S. G. Kandlikar, Numerical Investigation of Heat Transfer in Rectangular Microchannels under H2 Boundary Condition During Developing and Fully Developed Laminar Flow, *Journal of Heat Transfer*, February 2012, Volume 134 / 020911–10.
- [7] Sink For Electronics Cooling, *International Journal of Mechanical Engineering and Technology*, 6(11), 2015, pp. 145–153. *International Journal of Mechanical Engineering and Technology*, 5(12), 2014, pp. 86–96.
- [8] N. Bhagat and Shashi Kant, Amit Tiwari, Advanced Tool for Fluid Dynamics-CFD and its applications in Automotive, Aerodynamics and Machine Industry.

*International Journal of Mechanical Engineering and Technology*, 7(2), 2016, pp. 177–186.

- [9] Omar Mohammed Ismael, Dr. Ajeet Kumar Rai, Hasanfalah Mahdi and Vivek Sachan, An Experimental Study of Heat Transfer In A Plate Heat Exchanger. *International Journal of Mechanical Engineering and Technology*, 5(4), 2014, pp. 31–37.
- [10] Shakuntala Ojha, CFD Analysis on Forced Convection Cooling of Electronics Chips, Thesis, (2009).
- [11] Fluent 6 User's Guide, <http://www.fluent.com>.