

Eye Tracking Based Driver Drowsiness Monitoring And Warning System

Vema Dinesh¹, T Bathina Babu²

^{1,2} Dept of ECE

^{1,2} Seshachala Institute of Technology, Puttur

Abstract- This project is targeted at developing a safety system for automobiles which can be implemented making from providers. This could consequently provide both investments additionally to protection for the vehicle combined with the driver driving the car. If such systems enter existence lots of lives might be saved. This project signifies a method of developing an interface to recognize driver sleepiness based on continuously monitoring eyes and DIP computations. The development of technologies for preventing sleepiness within the wheel can be a major challenge in accident avoidance systems. Micro sleeps that is small amount of time of sleeps lasting 2 to 3 seconds are wonderful indicator of fatigue condition. Thus by continuously monitoring your vision in the driver through the use of camera you can find out the sleepy condition of driver and timely warning is launched. Goal in the project is always to obtain the hardware that's very advanced product connected with driver safety round the roads using controller and image processing. The merchandise detects driver sleepiness and offers warning healthy of alarm as well as lessens the rate of vehicle. Combined with sleepiness recognition process there's continuous monitoring in the distance produced by the Ultrasound sensor. The ultrasound sensor detects the obstacle and accordingly warns the motive pressure additionally to decreases speed of vehicle. Using MATLAB Graphical user interface is created. Graphical user interface enables us to create an interface involving the hardware and software.

Keywords- Drowsiness; Image Processing; Ultrasonic Sensor; Detection; Camera; Speed.

I. INTRODUCTION

Driver sleepiness recognition technologies can prevent a catastrophic accident by warning the motive pressure of his/her sleepiness. Concept of Driver Sleepiness Recognition System The main idea behind this project is always to produce a nonintrusive system that could identify sleepiness in the driver and issue a prompt warning [1]. Any kind of accident concerning driver sleepiness features a high fatality rate because the perception, recognition, and vehicle control abilities reduces significantly while shedding off and away to sleep. Preventing sleepiness during driving needs a

means of precisely finding a loss of revenue of driver performance plus a method of alerting and refreshing the motive pressure. Micro sleeps that is small amount of time of sleeps lasting 2 to 3 seconds are wonderful indicator of fatigue condition. Thus by constantly watching your vision in the driver you can find out the sleepy condition of driver in early stages to avoid accident. The current project can be a prototype in the model which may be recommended or produced to recognize the sleepiness in the driver and save the existence in the driver. The ingredients found in the job are microcontroller At mega AT89S52 which plays the vital role inside the functioning in the project, another components are L293D the motor driver IC familiar with drive the facility motor, Electricity motor utilized being an automobile, MAX 232 IC may be used to transform the present levels to TTL and the other way round. The digital camera continues to be used to capture the images in the driver's eye to recognize the health of sleepiness. For powering within the whole system we are using transformer based controlled supply. Motivation Sleepiness is probably the primary issues in road accidents. The fatality rate due sleepiness is larger. Any kind of accident concerning driver sleepiness features a high fatality rate because the observation, acknowledgement and vehicle control abilities reduce significantly while shedding off and away to sleep. The growing volume of accident fatalities in world lately has switched right into a problem of great concern for your society, so accidents ought to be prevented before they happen which factor lies while using driver. Accidents usually lead both economic additionally to social loss for the society. If accidents are prevented we could save many lives and along with the atmosphere may also be maintained [2]. The earlier systems used were pricey and. Preventing accidents introduced on by sleepiness needs a technique of finding sleepiness in the driver along with a technique of arousing the motive pressure from that sleepy condition. The job describes a technique that employs an image processing approach to recognize outdoors or closed condition in the driver's eyes as a way of finding sleepiness within the wheel. The electrodes that have been attached to the body in the driver were both annoying and tiring for your driver. The motive pressure appeared to become unable to concentrate on driving because of this. Along with

that electrodes needed daily substitute. Others that have been transported to find out the sleepiness in the driver used GSR, ECG, EMG. These also needed the attachment in the sensors towards against the motive force. Thus finding sleepiness and alerting the motive pressure can be useful for preventing accidents and lives might be saved [3]. We are searching for a technique which will instantly identify sleepiness based on driver's performance. Current systems familiar with identify sleepiness are slow and consume more hours to possess output and warn the motive pressure accordingly. The systems utilized may also be very pricey and so are implemented only in high quality or very pricey automobiles. Which means that the conventional automobiles lack such systems along with the security is low.

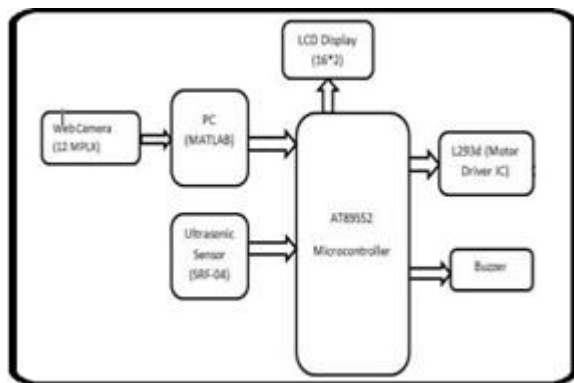

Fig.1. Data flow diagram of the proposed system

II. METHODOLOGY

We discuss laptop computer vision system we developed to get this done goal. Vision-Based Visual Cues Extraction Fatigue monitoring starts with getting rid of visual parameters typically characterizing a person's amount of vigilance. This really is accomplished utilizing a vision system in computer. The device includes two cameras: one wide position camera focusing obviously and yet another narrow position camera focusing on your vision. The wide angles camera monitors mind movement and facial expression because the narrow position camera monitors eye lid and gaze actions. Controller Based Sleepiness Recognition The recommended integrated system architecture is pictured in below figure. As seen the motive pressure monitoring system outputs are employed becoming an input for your controller as well as the control instructions are augmented with driver's instructions for your vehicle control in adverse conditions. An analysis system constantly decides using the risk level supplied by the motive pressure monitoring system, the car as well as the controller conditions. With your three information channels, diagnosing system can activate or deactivate the controllers in line with the particular situation. Inside the following sub-sections, monitoring and controller systems are

detailed. Finding The Physiological Response of Driver In this particular method the motive pressure sleepiness is supervised by planting various sensors round the driver's body. The sensors used are EKG (Electrocardiogram), GSR (Galvanic Skin Response), and EMG (Electromyogram). Diagnosing system structure requires several controllers and situations that require thinking about in the more extensive way. Therefore, in this particular situation study, the augmentation in the controller and driver for adjusting the automobile as well as the role in the monitoring system will be the focus. The device can be a specific solution for accident avoidance inside the situation of sleepiness/sleepiness while using assist from the adaptive robust lateral controller with speed regulation becoming an auxiliary system. The outputs brought on by these sensors are employed in figuring out the performance in the driver. Every one of these sensors ought to be continuously attached to the body of driver. The main problem with this method could be the aging in the sensor response. The images obtained from you're provided for the PC unit for processing. The finish increase the risk for PC unit is proven on screen. The ultrasound sensor keeps monitoring the area and along if obstacle detected it alerts the motive pressure. Thus this is often a safety system which supports in preventing accident. All the system and hardware components are initialized. We proceed and take video input via camera as well as the GUI input details are given somewhere. Eyes in the driver are continuously scanned. The motive pressure manually stops the alarm as well as the same process is moved further. Combined with sleepiness recognition process there's continuous monitoring in the distance produced by the Ultrasound sensor. The ultrasound sensor detects the obstacle and accordingly warns the motive pressure. Using MATLAB Graphical user interface is created. Graphical user interface enables us to create an interface involving the hardware and software [4]. It offers various push buttons like open eye template, close eye template, initialize camera. Furthermore, it consists of the edit button to edit the quantity of frames. Continuous checking of eyes is finished to evaluate when the driver is drowsy or else. That is made a decision with the open eye and shut template? For just about any given volume of iterations if consequently three frames of close eye template are situated with the system, the motive pressure is mentioned to get drowsy. Using handle we could vary from one resist another within that GUI. Continuously eyes are scanned with the camera and video preview is taken following a camera is initialized. After clicking the pushbutton of close eye template camera takes the preview and image is sprang later to match to the axes of close eye template. Command window in MATLAB shows the quantity of iterations been moved out and display 'Drowsy' if found drowsy. The procedure bears results which are greatly effective. Inside the finding the physiological response of driver method that we use ECG, EKG to recognize the

sleepiness in the driver in this particular scenario we showed up at understand that various instruments are mounted inside the vehicle as well as on the motorists body [5]. This method also produces very positive result. Thus the response produced by all the systems is not accurate therefore, it is greatly necessary to bring into picture this kind of system which assists in finding sleepiness at faster rate and provides efficient results. This method tires the motive pressure with a greater extend because the driver must be sitting lower in the constant position for your duration he drives the car. Just in case or on purpose is caused choice becomes very harmful for your driver. In these instances the motive pressure could even lose his existence. Inside the vision based system the cameras were installed on the dashboard which continuously continues checking the facial skin and provides the final results as designed. The device includes two cameras: one wide position camera focusing obviously and yet another narrow position camera focusing on your vision. The wide angles camera monitors mind movement and facial expression because the narrow position camera monitors eye lid and gaze actions.

III. CONCLUSION

Using MATLAB Graphical user interface is created. Graphical user interface enables us to create an interface involving the hardware and software. A non-intrusive method of sleepiness recognition can be achieved. Same method may apply to recognition of fatigue or other related driver performance. The digital camera continues to be used to capture the images in the driver's eye to recognize the health of sleepiness. For powering within the whole system we are using transformer based controlled supply. Motivation Sleepiness is probably the primary issues in road accidents. By monitoring your vision using camera and utilizing this new formula we could identify signs and signs and symptoms of driver fatigue in early stages to avoid any kind of accident. And this project will probably be helpful in finding driver fatigue in advance and may gave a reminder output healthy of appear. Also an ultrasound sensor which continuously monitors the area can be useful for remaining from accidents. Continuously eyes are scanned with the camera and video preview is taken following a camera is initialized.

REFERENCES

- [1] "Real Time and Non-intrusive Driver Fatigue Monitoring" Department of Electrical, Computer, and Systems Engineering 2004 IEEE Intelligent Transportation System Conference Washington, D.C., USA, October 36.2W4TuC4.4 Zhiwei Zhu* Qiang Ji**
- [2] "Development of drowsiness detection system" Vehicle Research Laboratory, Nissan Center NISSAN MOTOR

- Co., Ltd. Hiroshi Ueno Masayuki Kaneda Masataka Tsukino
- [3] "Face and eye tracking algorithm based on digital image processing" Department of Electrical Engineering, Universidad de Chile AV. Tupper 2007. Claudio A. Perez, Alvaro Palma, Carlos A. Holzmann and Christian Pera
- [4] "Active Accident Avoidance Case Study: Integrating Drowsiness Monitoring System with Lateral Control and Speed Regulation in Passenger Vehicles" Proceedings of the 2008 IEEE International Conference on Vehicular Electronics and Safety Columbus, OH, USA. September 22-24, 2008. Pinar Boyra, John H. L. Hansen
- [5] "Smartcard: Detecting Driver Stress" Massachusetts Institute of Technology Media Laboratory Jennifer Healey and Rosalind Picard.