

# Controlling of Electric Vehicle Using Relay

K. K. Mulmule<sup>1</sup>, D.D. Randive<sup>2</sup>, S.V. Chavan<sup>3</sup>, Dr. D. M. Holey<sup>4</sup>

<sup>1, 2, 3</sup>Dept of Electrical engineering

<sup>4</sup>Professor, Dept of Electrical engineering

<sup>1, 2, 3, 4</sup>KDKC/RTMNU, Maharashtra, India

**Abstract-** Three wheel balancing vehicle is a transportation device. In these we designed and constructed mechanically based system for a three wheel balancing vehicle. This consist of forward and backward movement. The main objective was to build a vehicle capable of transporting a person weighing a up to 70-80 kg and capable of traveling to some km distance with constant speed the design of human transporter is such that it covers less space and comfort to use. An experimental model has been designed and implemented through this study. The name aim of our project is that goods transportations device which can be driven by anyone this kind of vehicle is interesting since it contains lot of technology relevant to an environmentally friendly and energy efficient transportation industry. It has the bright future. It will eventually be widely used and accepted as a form of transportation i.e. better than bicycle. The aim of the project work is to build up at a very low cost, highly efficient rate and easy handle an operating also.

will be open and relay RL3 will be closed which are of right motor and hence , vehicle will move in forward direction. When switch S2 is closed and all other switches are kept to be open then relay RL1 will be open and RL2 will be closed which is are left motor and relay RL3 will be open and RL4 will be closed which are of right motor and hence, vehicle will move in reverse(backward) direction. When switch S3 is closed and all other switches are kept open then relay RL1 will be open and RL2 will be closed which are of left motor and relay RL3 will be closed and relay RL4 will be open which are of right motor and hence vehicle will move in the left direction. When switch S4 is closed and all other switches are kept open then relay RL1 will be closed and RL2 will be open which are of left motor and relay RL3 will be open and RL4 will be closed which are of right motor and hence vehicle will move in right direction. During breaking all of the switches will be kept open i.e. switches S1,S2, S3 and S4 will be open.

## I. INTRODUCTION

The three wheel electric vehicle is self balancing and battery powered electric vehicle. This vehicle is driven standing up which is use to transportation of human from one location to another location. There is no break and accelerator. In this vehicle it has controller for movement of vehicle which is move to forward direction and reverse direction and to turn left and right. Basically this vehicle like a scooter but the vehicle arrangement is parallel to each other are placed side by side and the DC motor is used on both side. There are various innovation on going in field of electric transportation and there is a gyroscope is for balancing but in this vehicle third wheel is used for balancing which is zero turn radius and balance itself. The advantages of this vehicle is has safe travelling speed and it produce zero emission. Any transportation vehicle needed lots of fossile fuel which emits carbon and prevent pollution.

## II. OPERATING RELAY

We have four switches for forward, reverse left and right movement of vehicle. When switch S1 is closed and other switches will open then relay RL1 one will be closed and relay RL2 will open which are of left motor, and relay RL3

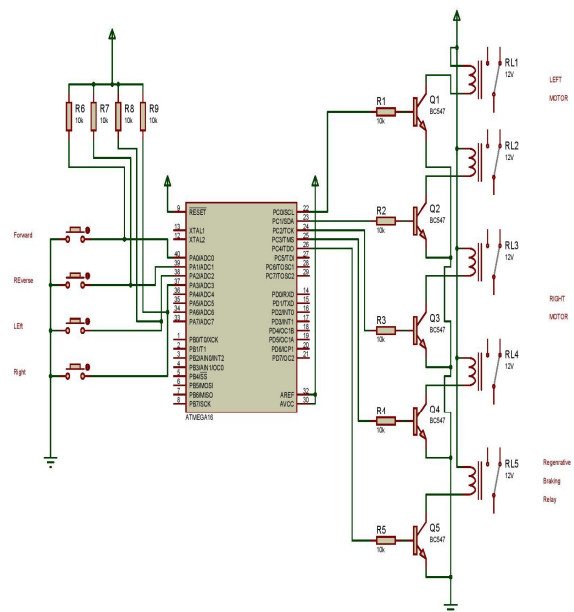

Fig2.1 operating relay

## III. CONCLUSIONS

In this project we will be designing the electric vehicle for more efficient use of energy and providing the alternatives from an eco friendly. The main objective is to achieve space utilization and minimize the fuel consumption

especially for commuting a over shortest distance. Due to regenerative breaking the efficiency of vehicle is increasing. It clear from our research this will be chief and alternative way for transportation in uraban as well as rural area which is advanced and comparative chief than current conventional vehicles.

### REFERENCES

- [1] Mr.Velaji Hadiya, Mr. Akash Rai, Mr.Sushant Sharma, Miss. Ashwini More,"Design and Development of Segway", IRJET, Volume:03, Issue:05,May-2016.
- [2] Mr. Mayank Sharma, Rahul sharma, Kshitij Singh,Vikrant Sinha, Shakil Tadavi,"Segway-The Human Transporter ",IJIRST, Volume1,Issue11,April 2015.
- [3] B. Harshavardhan Reddy ,G Ravi Teja Reddy , G Suresh ,M Vinodh Kumar Reddy, N. Prassana Kumar, B.Venu,"Design and Fabrication of Fail Safe Segway ",IOSR-JMCE,Volume 12, Issue 3.
- [4] J.B.Gupta, Theory and Performance of electrical Machines, 14th edition ,SK Kataria and Sons,2010
- [5] M.V.Kothari, Design and Testing of Electrical machine.
- [6] Ankit S. Khanzode, Ashish G. Masne, Mohd.Shahzad Gulam Ali, Akshay P.Tale,Kamalkishore G Maniyar,"Mechanical Segway",IJETR, Volume-4,Issue-3,March 2016.
- [7] Prof.Yogesh Risodkar, Mr.Ganesh Shirsath, Ms.Monali Holkar, Mr.Mayur Amle,"Designing the Self- Balancing Platform(Segway),"IJETR, Volume 4, Issue 9, September 2015.