

Advanced Electric Vehicle Charging Station

Anne Mary Thomas¹, Bhavana V², Gopika S³, Karthika K⁴, Salini M⁵

^{1, 2, 3, 4, 5} NCERC, PAMPADY, THRISSUR, KERALA

Abstract- This project focuses on implementing electric vehicle (EV) charging stations with ready to use replaceable batteries at affordable time and cost. Electric vehicles are a sure solution for cutting down toxic exhausts from ever increasing automobile population. An alarming rate of global warming and climate change is posing threat to planet earth, green energy is always in demand. Through this project we are trying to implement a battery swapping system (BSS) for electric vehicles at charging stations to cut down time of charging and increase availability of energy. An EV is supposed to enter a charging station with options of AC charging, DC quick charging and ready to use rechargeable battery. Existing and going to be implemented charging stations are main targets of this project. An automatic battery swapping mechanism (BSM) between vehicle and charging stations with much lesser time than complete filling fuel tank is aimed. To meet daily demand of public, a software application is also planned for searching availability and booking of charged batteries at nearby stations en route using mobile application.

Keywords- Battery Swapping, Electric Vehicle, Swapping Station Manager, Telecommunication Interfaces.

I. INTRODUCTION

Exponentially rising environment pollution and fossil fuel prices encouraged Indian government to promote more and more electric vehicles[1]. Electric vehicles are highly attractive due to low amount of green house gas emission, high efficiency and its capability to support grid at times of peak demands[1] [2]. For EVs to be adopted at larger scale, the charging infrastructure and integration with the power grid must also be evolved. An emerging type of charging is based on battery swapping. In the current scenario, the most common way of charging the electric vehicle is the battery being connected to the charging station with a cable when the vehicle is in stationary condition [2]. It takes much more time for charging, about half an hour. In our project we proposed a best solution for this by the swapping technique of battery. This project focuses on implementing electric vehicle charging stations with ready to use replaceable batteries at cost and this technique needs less time for charging [2] [5]. An optimized battery swapping station (BSS) has been presented in, however, this method is based on the assumption that consumers are willing to lease their battery as opposed to

owning the battery [8]. Electric vehicles charging consumes time. But because of the lag in charging public are not interested in using electric vehicle. When we implement charging station with battery swapping technique the problem of time lag get reduced and the public also get attracted to electric vehicle. And this is the step to green mobility. The third party will have the ownership of the battery and will be liable for replacing the drained batteries with fresh, charged and standard ones is shown in the Fig.1.

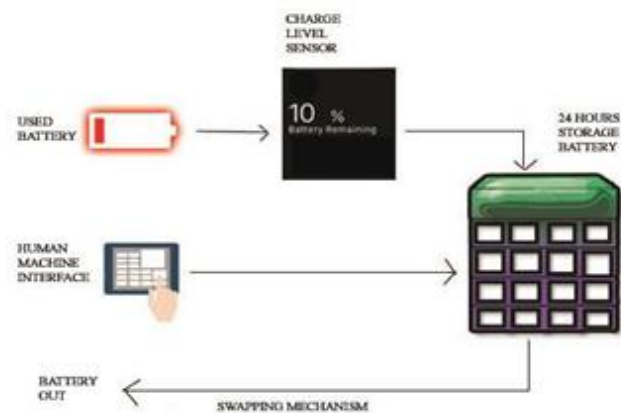

Fig.1. Battery Swapping Station

II. NEED

- A better alternative to fast charging. Technological support for reserving batteries for the user.
- Using this technique vehicles can charge simultaneously within a short time when vehicle population increases.
- Electric vehicles produce less Carbon Emission pollution compared to conventional vehicles, it also provides a cleaner way of transportation by cutting down oil usage.

III. GAP IDENTIFICATION

- Due to increase in population there is a huge decrease in fossil fuels and petroleum products.
- The battery charging in EV by using renewable energy source is pollution free and abundant in nature.
- By the battery swapping technique, the time consumption is less than petroleum.
- Using this technique vehicles can charge simultaneously within a short time when vehicle population increases.

- This became cost effective than petroleum vehicles by the use of renewable sources.

IV. PROPOSED IDEA

The Battery swapping mechanism is designed with a conveyor belt and motors. The input of battery and specification from user will be controlled via microcontroller. The Swapping Station Manager (SSM) manages the charging of the batteries in a battery swapping station, with the aim of providing fully charged batteries to the EVs in exchange for their depleted batteries is shown in Fig.2.

The management of the EV battery charging is dependent on:

- The number of chargers installed in the swapping station.
- The number of batteries in the swapping station. This number remains constant since for every fully charged battery delivered a depleted battery is acquired.

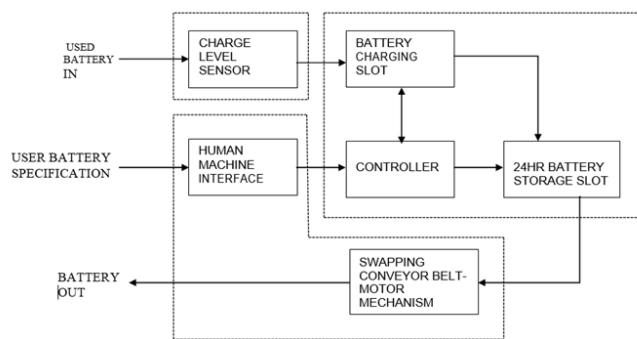

.2.BASIC BLOCK DIAGRAM OF BSS

The Basic Block Diagram consist of 3 functional part

1. Sensor Unit
2. Swapping Station Manager
3. Battery Management Unit

A. Sensor Unit

Sensor Unit monitors the state of battery (SoB). Sensor unit connects to a temperature sensor to transmit the signal elsewhere for monitoring and control purposes. The DM640 range of battery powered thermometers accept signals from either Pt100 or thermocouple sensor and displays the temperature on its Liquid Crystal Display (LCD) display.

B. Swapping Station Manager

The BSN consists of several functional subsystems; the communication between these systems is handled by the

Swapping Station Manager through the Internet of Things (IoT) and telecommunication interfaces, communicating to optimize the cost of charging, reduce the waiting time for battery swaps by forecasting battery swaps and share the UBPs amongst each other through participating EVs and EV customers. This system coordinates the bidirectional flow of power between the SSM and the smart grid which is designed for distributed generation and bidirectional power flow. It also coordinates the optimized routing of boost packs in the BSN through the EVs that participate in the network.

C. Battery Management Unit

The batteries and chargers required to satisfy battery daily demand in a swapping station, is analysed. The battery is connected to a charger and charged completely. When the battery has finished its charging process, it is available to be swapped. The charged batteries drive up to an EV to swap a battery within a few minutes.

V. FUTURE SCOPE

Once the lithium ion batteries become standardized, we aim to introduce an app for pre- booking of charged batteries for daily public needs.

Expand the batteries swapping to heavy load vehicles, public transport etc

VI. CONCLUSION

The proposed project has a major role in automobile industry. By adopting swapping mechanism, we can reduce the battery charging time of an electric vehicle. Customer can select the battery according to their need and make payment for the particular battery charge level. An Electric Vehicle charging system both customer friendly and affordable.

REFERENCES

- [1] Fatemah Jozi, Kazem Mazlumi, Hadi Hasseini (2017) - "Charging and discharging coordination of electric vehicles in a parking lot considering the limitation of power exchange with the distribution system".
- [2] Till Gnanna,, Simon Funkea, Niklas Jakobssonb, Patrick Plötza, Frances Spreib, Anders BennehagcH (2018) - "Fast charging infrastructure for electric vehicles: Today's situation and future needs".
- [3] Shaohua Cui, Hui Zhao, Huijie Wen and Cuiping Zhang (2018) - "Locating Multiple Size and Multiple Type of Charging Station for Battery Electricity Vehicles".

- [4] Mr. Varawut Kornsilruk -Department of Research and Development, Metropolitan Electricity Authority, Thailand (2019) -*“Study ofEnergy Storage System: Concept of Using ESS in EV Charging Stations in MEA”*.
- [5] Hassan S. Hayajneh, Muath Naser Bani Salim, Srikanth Bashetty, and Xuewei Zhang Frank H. Dotterweich College of Engineering (2019) -*“Optimal Planning of Battery- Powered ElectricVehicle Charging Station Networks”*.
- [6] Anjeet Verma Member, IEEE and Bhim Singh, *Fellow, IEEE* Indian Institute of Technology, New Delhi, India (2019) -*” An Implementation ofRenewable Energy Based Grid Interactive Charging Station”*
- [7] K. Sankaraditya Vikas, B.Raviteja Reddy, M. R. Sindhu (2019) -*“Controller for charging electricvehicles at workplaces using solar energy”*.
- [8] Feyijimi Adegbohun , Annette von Jouanne and Kwang Y. Lee Department of Electrical and Computer Engineering, Baylor University (2019) -*“Autonomous Battery Swapping System andMethodologies of Electric Vehicles ”*.
- [9] Jie yang, Weiqiang wang , Kai ma and Bo yang(2019) -*“Optimal Dispatching Strategy for Shared Battery Station of Electric Vehicle by Divisional Battery Control”*
- [10]Sreeram k Dept.of Electrical and Electronics Engineering Amrita Vishwa Vidyapeetham Amritapuri India(2019) - *“ElectricVehicle Scenario in India : Roadmap, Challenges and Opportunities”*.



GOPIKA S is currently pursuing BTech degree in electrical and electronics engineering with KTU university, SEEM member.



KARTHIKA K is currentlypursuing BTech degree in electrical and electronics engineering with KTU university, SEEM member.



SALINI M is currentlypursuing BTech degree in electrical and electronics engineering with KTU university, SEEM member.

AUTHORS PROFILE



ANNE MARY THOMAS iscurrently pursuing BTech degree in electrical and electronics engineering with KTU university, SEEM member,.



BHAVANA V is currentlypursuing BTech degree in electrical and electronics engineering with KTU university, SEEM member.