

Control Strategy For Distributed Generation Units Through Active Power Sharing & Frequency Recovery

Swapnil Chopade¹, Prof. Ajit P. Chaudhari², Prof. Girish K Mahajan³

¹Dept of Electrical Engg

^{2,3}Associate Professor, Dept of Electrical Engg

^{1,2,3}SSGBCOET Bhusawal

Abstract- Due to growth in the global population, as well as the increase in the use of devices that consume electricity, demand for electrical power has grown to unprecedented levels. However, the electricity supply has become saturated due to environmental, social, and geographical factors. To address these problems, attempts have been made to meet the electrical energy demand locally via Microgrid and distributed generations (DGs). Small sized synchronous generator based distributed generators (DG) often have low start-up times and can serve as dispatch able generators in a Microgrid environment. The advantage is that it allows the power network to operate in a true smart grid environment. The disadvantage is that such DGs typically tend to have low inertia and the prime movers driving these resources need to be controlled in real time for them to operate effectively in islanded, grid-connected modes and during transition from grid connected mode to islanded mode and vice versa. When multiple DGs are present in the Microgrid, the overall control can become complicated because of the need for sharing the resources. A smart grid environment is then necessary to control all dispersed generation sources in the Microgrid. The most common control strategy adopted for multiple DGs connected to a network is droop control. Droop control ensures that the load needed to be served is shared by all the generators in the network in proportion to their generating capability.

Keywords- DG, MGCC, MC, MATLAB, CC, IC, DER, ESSs, CERTS, ADS, VPP, IGBT

I. INTRODUCTION

Due to increase in demand of electricity as use of devices that consume electricity increases. The major problem is to meet this demand of electricity. However, the electricity supply has become saturated due some factors such as social, environmental and geographical. To fulfill these problems and to meet the electricity demand there are two ways such as via micro grids and distributed generation (DGs). Microgrid works with two operating modes of operation such as grid integrated mode and islanded mode of operation. In case of grid connected operation, micro grid is connected to main grid

having large system inertia which helps to maintain micro grid frequency almost to nominal value. But in case of islanded mode operation micro grid must supply its own demand and maintain its frequency which is mainly done by DG units. There are various methods or control techniques for distributed generation to control active power sharing as well as frequency in islanded micro grids. Generally, most commonly used method of control is droop control. In active power-frequency (P-f) droop control was developed for active power sharing by emulating conventional power systems composed of synchronous generators. In oppose to conventional droop control, a tunable droop controller with two degrees of freedom was proposed, considering an adaptive transient droop function. Islanded Micro-grid were introduces for Single-master and multiple-master operating modes considering secondary load-frequency control for frequency recovery. This difference is fed into the integrators of self-frequency recovery control which may cause the error in operation of active power sharing. So, to solve this problem new technique or control method is developed which share active power more accurately, this method is compensation control method. In that active power sharing is done by considering droop coefficients of each of DG units. A DG control method that simultaneously implements accurate active power sharing and self-frequency recovery. Using this control method, DG units share the changes in load with a predetermined ratio and are able to restore their output frequency to the nominal value autonomously (hence the term “self-frequency recovery”) immediately following a change in load. However, the self-frequency recovery action may lead to (small) errors in power sharing due to variations in the impedance among DG units. However, the self-frequency recovery action may lead to (small) errors in power sharing due to variations in the impedance among DG units. Therefore, following frequency recovery, the active power sharing among DG units is readjusted to the predetermined ratio using a compensation control scheme. The control method was modeled and tested using MATLAB/Simulink, and the simulation results demonstrate the effectiveness of the approach.

A. MICROGRID CONCEPT

The main components of Microgrid are mini-hydro, solar cell, wind energy, fuel cell and energy storage system. These are integrated for electricity generation, energy storage, and a load that normally operates connected to a main grid (micro grid). Generation and loads in a Microgrid are usually interconnected at low voltage. But one issue related to Microgrid is that operator should be very alert because numbers of power system are connected to Microgrid. In the past, there was single entity to control. In Microgrid generation resources can include such as fuel cells, wind, solar, or other energy sources. These multiple different electric power supply generation resources have ability to isolate the Microgrid from a large network and will provide highly reliable electric power. Produced heat from generation sources such as micro turbines could be used for local process heating or space heating, allowing flexible trade-off between the needs for heat and electric power.

The followings are parameters of Microgrid:

- Small Microgrid covers 30 - 50 km radius;
- The small Microgrid can produce power of 5 - 10 MW to serve the customers;
- It is free from huge transmission losses and also free from dependencies on long-distance transmission lines.

CERTS Microgrid has two critical components, the static switch and the micro source. The static switch has the ability to autonomously island the Microgrid from disturbances such as faults, IEEE 1547 events or power quality events. After islanding, the reconnection of the micro grid is achieved autonomously after the tripping event is no longer present. This synchronization is achieved by using the frequency difference between the islanded micro grid and the utility grid insuring a transient free operation without having to match frequency and phase angles at the connection point. Each micro source can seamlessly balance the power on the islanded microgrid using a power vs. frequency droop controller. This frequency droop also insures that the Microgrid frequency is different from the grid to facilitate reconnection to the utility.

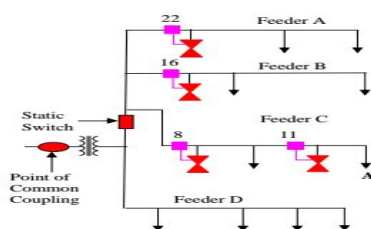

Fig.1. Basic Microgrid architecture

Basic Microgrid architecture is shown in Figure 1. This consists of a group of radial feeders, which could be part of a distribution system or a building's electrical system. There is a single point of connection to the utility called point of common coupling (Lasseter 2002b). Some feeders, (Feeders A-C) have sensitive loads, which require local generation. The non-critical load feeders do not have any local generation. Feeders A-C can island from the grid using the static switch that can separate in less than a cycle (Zang 2003). In this example there are four micro sources at nodes 8, 11, 16 and 22, which control the operation using only local voltages and currents measurements.

When there is a problem with the utility supply the static switch will open, isolating the sensitive loads from the power grid. Non-sensitive loads (feeder D) rides through on feeders A, B, and C to meet the loads on these feeders. When the Microgrid is grid-connected power from the local generation can be directed to the no sensitive loads. To achieve this, we promote autonomous control in a peer-to-peer and plug-and-play operation model for each component of the Microgrid. The peer-to-peer concept insures that there are no components, such as a master controller or central storage unit that is critical for operation of the Microgrid. This implies that the Microgrid can continue operating with loss of any component or generator. With one additional source (N+1) we can insure complete functionality with the loss of any source. Plug-and-play implies that a unit can be placed at any point on the electrical system without reengineering the controls.

II. CONTROL & CONFIGURATION

A. Unit Power Control Configuration

In this configuration each DG regulates the voltage magnitude at the connection point and the power that the source is injecting, P . This is the power that flows from the micro source as shown in Figure 1. With this configuration, if a load increases anywhere in the Microgrid, the extra power come from the grid, since every unit regulates to constant output power. This configuration fits CHP applications because production of power depends on the heat demand. Electricity production makes sense only at high efficiencies, which can only be obtained only when the waste heat is utilized. When the system islands the local power vs. frequency droop function insures that the power is balanced within the island.

B. Feeder Flow Control Configuration

In this configuration, each DG regulates the voltage magnitude at the connection point and the power that is

flowing in the feeder at the points 8, 11, 16 and 22 in Figure 1. With this configuration extra load demands are picked up by the DG, showing a constant load to the utility grid. In this case, the Microgrid becomes a true dispatch able load as seen from the utility side, allowing for demand-side management arrangements. Again, when the system islands the local feeder flow vs. frequency droop function insures that the power is balanced.

C. Mixed Control Configuration

In this configuration, some of the DGs regulate their output power, P, while some others regulate the feeder power flow. The same unit could control either power or flow depending on the needs. This configuration could potentially offer the best of both worlds: some units operating at peak efficiency recuperating waste heat, some other units ensuring that the power flow from the grid stays constant under changing load conditions within the Microgrid.

III. SYSTEM DEVELOPMENT

MATLAB is a multi-level language and interactive environment for numerical computation, visualization, and programming. Using MATLAB, analysis of data, develop algorithms, and create models and applications are done. The language, tools, and built-in math functions enable to explore multiple approaches and reach a solution faster than with spreadsheets or traditional programming languages, such as C/C++ or Java. MATLAB can be used for a range of applications, including signal processing and communications, image and video processing, control systems, test and measurement, computational finance, and computational biology.

The name MATLAB stands for Matrix Laboratory. MATLAB was originally written to provide easy access to matrix software developed by linpack and eispack projects. Today, MATLAB engines incorporate the lapack and blas libraries, embedded the state of the art in software for matrix computation.

MATLAB is a very powerful package which allows to manipulate simultaneously:

- Complex functions of complex variables
- Electrical power systems are combination of electrical circuits, and electromechanical devices, like motors and generator. Engineers working in this discipline are constantly asked to improve the performance of the systems.

- Requirement for drastically increased efficiency have a forced power system designer to use power electronics devices and sophisticated control system concepts that tax traditional analysis tools and techniques.
- Further complicating the analyst's role is the fact that the system is often so nonlinear, the only way to understand it is through simulation.
- Comprehensive Block Libraries
- The Sim Power System libraries contain more than 150 blocks distributed in eight sub libraries. The blocks represent simple electrical components, such as resistors, inductors, and capacitors, and complex components, such as transistors and electric drives. The lines joining these components represent ideal conduction lines. Numeric signals can be 24 passes into the circuit model from Simulink and extract numeric signals from the circuit model for analysis in tradition Simulink blocks.
- The library can be used with Simulink to create electrical block diagrams that connect Sim Power Systems elements and control algorithms, enabling to study the way the control system relates the power system.
- The Sim Power Systems library includes the following sub libraries:
- Electrical sources-AC and DC voltage and current sources.
- Electrical circuit elements-resistor, inductor, capacitor; linear and saturable transformers; arrestors and breakers; and transmission line models.
- Electrical machinery-models of synchronous, permanent magnet synchronous, and DC machines; excitation systems; and models of both hydraulic and steam turbine governor system.
- Power electronics-diodes simplified and complex thyristors, GTOs, switches, MOSFETs, IGBT models, and Universal Bridge

IV. PERFORMANCE ANALYSIS

MATLAB (matrix laboratory) is a multi-paradigm numerical computing environment and fourth-generation programming language. A proprietary programming language developed by Math Works, MATLAB allows matrix manipulations, plotting of functions and data, implementation of algorithms, creation of user interfaces, and interfacing with programs written in other languages, including C, C++, Java, Fortran and Python. Although MATLAB is intended primarily for numerical computing, an optional toolbox uses the MuPAD symbolic engine, allowing access to symbolic computing abilities. An additional package, Simulink, adds

graphical multi-domain simulation and model-based design for dynamic and embedded systems. The MATLAB application is built around the MATLAB scripting language. Common usage of the MATLAB application involves using the Command Window as an interactive mathematical shell or executing text files containing MATLAB code. MATLAB has structure data types. Since all variables in MATLAB are arrays, a more adequate name is "structure array", where each element of the array has the same field names. In addition, MATLAB supports dynamic field names (field look-ups by name, field manipulations, etc.). Unfortunately, MATLAB JIT does not support MATLAB structures, therefore just a simple bundling of various variables into a structure will come at a cost. When creating a MATLAB function, the name of the file should match the name of the first function in the file. Valid function names begin with an alphabetic character, and can contain letters, numbers, or underscores. Functions are also often case sensitive. MATLAB supports elements of lambda calculus by introducing function handles, or function references, which are implemented either in .m files or anonymous /nested functions. MATLAB supports developing applications with graphical user interface (GUI) features. MATLAB includes GUIDE (GUI development environment) for graphically designing GUIs. It also has tightly integrated graph-plotting features. MATLAB can call functions and subroutines written in the programming languages C or FORTRAN.

New capabilities for the MATLAB product family include:

- Multicore support for fft and other MATLAB functions
- Utilization of eight cores on your desktop with Parallel Computing Toolbox
- Ability to use .NET classes directly in MATLAB programs and applications
- Surface fitting, including surface fit objects and a new GUI in Curve Fitting Toolbox
- Generation of Simulink blocks from symbolic math expressions in Symbolic Math Toolbox
- Vehicle Network Toolbox, a new product for communicating with in-vehicle networks using CAN protocol.
- New capabilities for the Simulink product family include
- Save, restore, and restart simulation states in Simulink and State flow.
- Fixed-point support for Discrete Filter block and auto scaling of Simulink data objects in Simulink Fixed Point.

- Configure and generate code based on high-level objectives, such as efficiency and traceability in Real-Time Workshop Embedded Coder.
- Reduced RAM usage, faster execution time and other code efficiency improvements in Real-Time Workshop and Real-Time Workshop Embedded Coder.

A. Simulation Model of Distributed Generation Units And Islanded Microgrid.

First of all, simulation is done by DG units and Islanded Microgrid, loads and results are monitored.

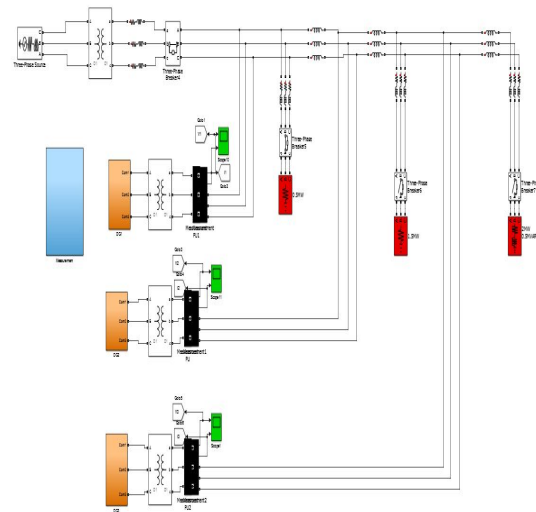

Fig.2.Simulation Model of Distributed Generation Units and Islanded Microgrid.

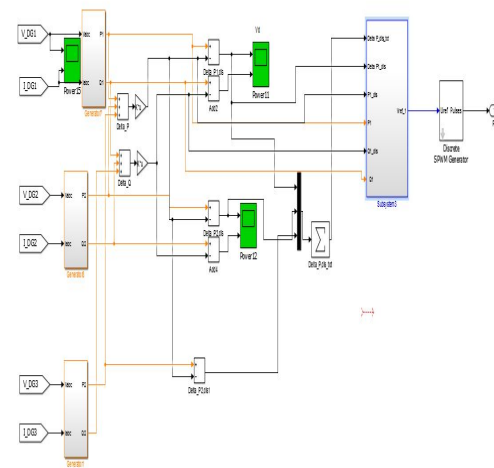

Fig.3.Control Model of system configuration.

V. RESULTS ANALYSIS

To verify the effectiveness of the proposed control method for DG units, case studies were implemented. The control performance of the Microgrid was investigated for active power sharing, and for each the proposed control method was compared with conventional $P-f$ droop control. The change in the active power load should be shared equally among the DG units; therefore, the $P-f$ and $Q-V$ droop coefficients were equal for each DG unit (i.e., $m = 0.02$) The DG controller for the conventional control method, which enables both self-frequency recovery control and compensation control. Fig.4,5 shows the simulated active power of each DG unit conventional $P-f$ droop control. Prior to islanded operation of the Microgrid, each DG unit injected (i.e., the dispatched value from the CC) into the grid.

A. Increases in Load

Initial load 0.5 MW, at 0.25s increased by 2MW and 0.5MVAR, at 0.5s increased by 1.5MW

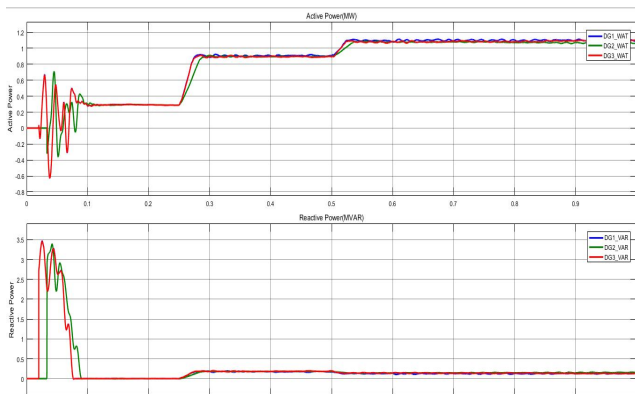

Fig 4(a): Simulation results for DG1,DG2 ,DG3 (a) Output active power. (b) Output reactive power.

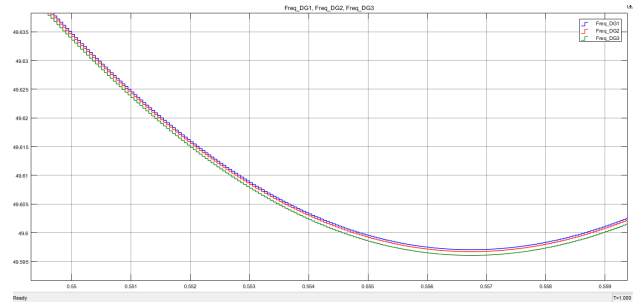
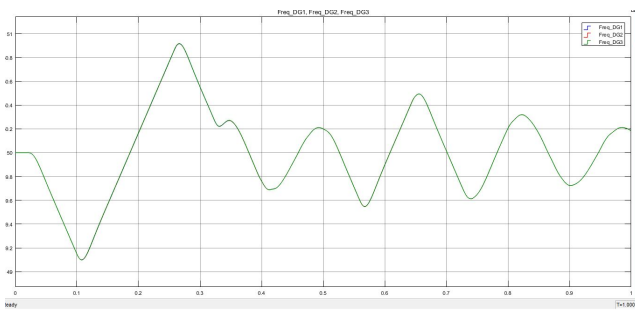

Fig.5. Simulation results for frequency DG1,DG2,DG3

At 0.25s, Initial load increased from 0.5 MW to 2MW. As shown Figure active and reactive power was equally shared among DG units. The frequency should recover to the nominal value, according to the grid code requirements. To achieve this, another DG unit must be controlled separately during frequency restoration. As discussed in the previous section; too great a burden may be Imposed on the frequency control units if the load change is large. To eliminate the requirement for secondary frequency control, as well as to share the burden of frequency restoration, self-frequency recovery control was implemented with compensation control. Fig. 4(a) shows the simulated active power and reactive power. Following the transition from grid-connected mode to islanded mode at 0.1 s, the additional required active power was shared among the DG units. In contrast to the conventional method, the DG units were unable to share the active power equally [see at 0.25–0.35 s of Fig. 4(a)], despite equal droop coefficients, because the self-frequency recovery control term was added to the controller. Self-frequency recovery control resulted in active power sharing error, as described in Chapter 3. Following the change in load at 0.25 s, the error in the active power sharing increased.

B. Decreases in Load

At 0.25s, initial load 4MW is reduced by 2 MW. At 0.25s, initial load 0.5MVAR is reduced by 1.5MW. In this case, the load is decreased from 4 to 2 MW. Initially, the active power sharing differed slightly among the DGs; however, in the steady state, each DG unit injected the same amount of active power. This process can be implemented according to (2), such that the output frequency of each DG unit was equal in the steady state, as shown in Fig. 6. However, as described in (5) and (6), the output frequency of each DG unit will differ [see in Fig.6. With the conventional method, frequency deviations are inevitable, as shown in Fig. 6. Fig. 5(a) show the active power and reactive power respectively. Since there are no reactive power load, the output reactive powers are exactly zero at 0.3–0.6s in Fig. 5. This is because for all DG units, the active and reactive power loads are same with same electrical distances . However, at 0.25 s,

since the load is changed, and the voltage deviation is happened, the output reactive powers become slightly different from each other. Initial load 4MW, 0.5MVAR, At 0.25S, reduced by 2MW&0.5MVAR At0.5s, reduced by 1.5MW

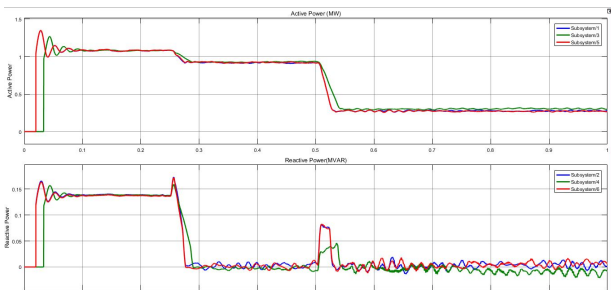

Fig 5. Simulation results for DG1, DG2, DG3 Output active power.

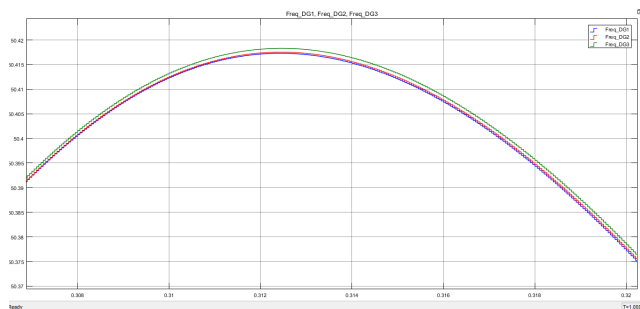

Fig 6. Simulation results for DG1, DG2, DG3) Output reactive power.

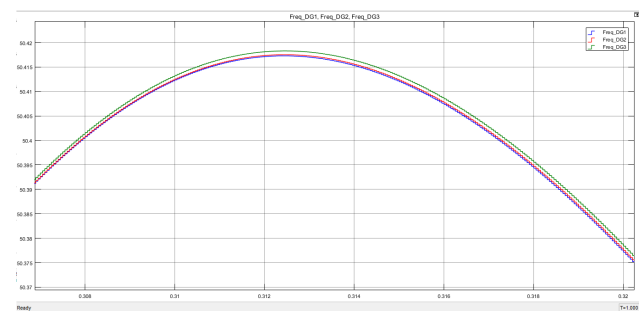

Fig.7.Simulation results for frequency DG1, DG2, DG3

C. Delay in synchronization

To verify that the active power can be shared according to the desired ratio using the proposed control method, Consequently, DG2 and DG3 should share the load, and change twice as much as DG1. Fig. 8(a) shows the simulated active power and reactive power droop control method. After the static switch was opened, the active power that was injected from the main grid was shared among the DG units according to the predetermined ratio (based on the droop coefficients). At 0.1 s, the load changed, and this change was shared among the DG units as shown in Fig. 8(a).

At 0.1 s the active power outputs of DG2 and DG3 were equal, which means that the active power was shared according to the predetermined ratio. As with previous case 4.3.1, 4.3.2, frequency deviation was inevitable, as shown in Fig. 8(b). The frequency deviation requires frequency restoration control. The output frequency difference among the DG units was not addressed again in this case. Since the active power of DG1 is different from DG2 and DG3, it can be seen that the reactive power of DG1 is also different from DG2 and DG3. Hence, though its influence is small, it can be noticed that the active power and the reactive power are correlated even in the medium-voltage network. Fig.8(a) shows simulated results with the proposed control method. Upto 0.1 s, the active power outputs of DG2 and DG3 differed (although they should have been equal as they had the same droop coefficient). As expected, active power sharing was not implemented accurately, even after the load change at 0.1 s [see Fig.8(a)]. To compensate for these errors, compensation control was activated at 0.1s. As a consequence, active power sharing was implemented accurately within 0.3 s (see 0.1–0.4 s), as shown in Fig. 4.6(a). At 0.4 s active power outputs of DG1, DG2, DG3 were equal as shown. Simulation results for frequency DG1, DG2, DG3 as shown in fig.6(b). DG1 Synchronized after 0.1S

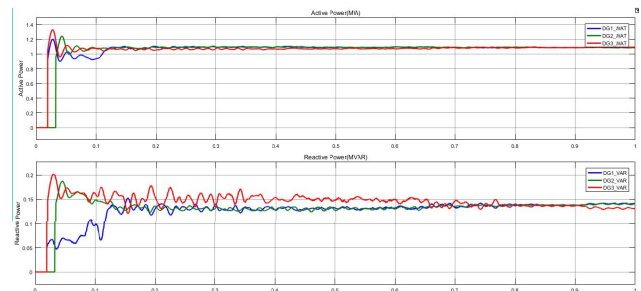
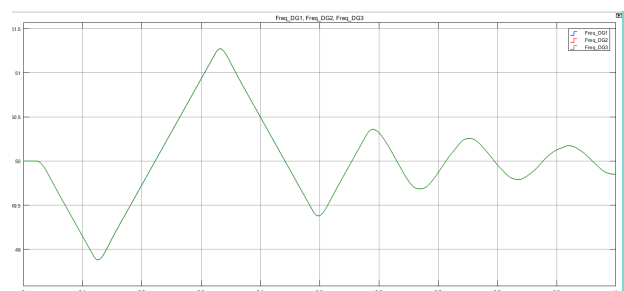

Fig.8.(a)Simulation results for DG1, DG2, DG3 (a) Output active power. (b) Output reactive power.



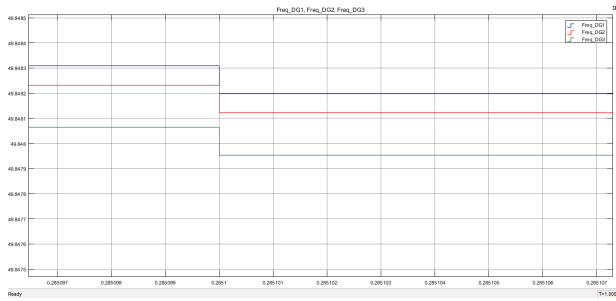

Fig.9. Simulation results for frequency DG1, DG2, DG3

VI. CONCLUSION

We have described a control method for DG units to implement accurate active power sharing and self-frequency recovery in an islanded Microgrid. Islanded Microgrid have low inertia, and so they are vulnerable to the frequency disturbances, and frequency recovery is important. Conventionally, frequency restoration is implemented via secondary frequency control units, where the active power sharing units and the frequency control units are controlled separately. Specific units (i.e., frequency control units) are required to account for changes in load, which may cause them to reach their output limit more quickly and hence to increase generation cost exponentially.

Moreover, if the frequency deviation is too great, this may lead to a loss of capability of the frequency control units, especially in a small isolated power system such as an islanded Microgrid. Hence, it is desirable to share the frequency deviation among all DG units according to a predetermined ratio. As shown by the results of the simulation case studies, the frequency was restored almost immediately following frequency deviation using self-frequency control, and the active power was shared according to droop control and compensation control.

REFERENCES

- [1] Yun-Su Kim, Student Member, IEEE, Eung-Sang Kim, and Seung -Il Moon, Senior Member, IEEE “Distributed Generation Control Method for Active Power Sharing and Self-Frequency Recovery in an Islanded Microgrid” *IEEE Trans. Power Syst.*, 0885-8950 © 2016 IEEE.
- [2] Mr. Y R Shinde, Mr. S S Khule, Department of Electrical Engg, Matoshri COE Nashik, India., “Active Power Sharing and Self Frequency Recovery in an Islanded Microgrid” Vol 2. Issue, January 2017, IJSTMR © 2017.
- [3] T. L. Vandoorn, J. D. M. De Kooing, B. Meersman and L. Vandeveldel, Dept of Electrical Energy, Systems & Automation, Ghent University, “Improvement Of active power sharing ratio of P/V droop controllers in low – voltage islanded microgrids”
- [4] Alireza Kahrobaeian, Student Member, IEEE, and Yasser Abdel-Rady Ibrahim Mohamed, Senior Member, *IEEE Trans. Power Electronics*, vol. 30, no. 2, pp. Feb 2015.
- [5] B. Lasseter, “Microgrids [distributed power generation],” in *Proc. IEEE Power Eng. Soc. Winter Meet.*, Columbus, OH, USA, Jan. 2001, vol. 1, pp. 146–149.
- [6] R. H. Lasseter, “Microgrids,” in *Proc. IEEE Power Eng. Soc. Winter Meet.*, Jan. 2002, vol. 1, pp. 305–308.
- [7] F. Katiraei, R. Iravani, N. Hatziargyriou, and A. Dimeas, “Microgrids management: Controls and operation aspects of microgrids,” *IEEE Power Energy Mag.*, vol. 6, no. 3, pp. 54–65, May/Jun. 2008.
- [8] S.-J. Ahn *et al.*, “Power-sharing method of multiple distributed generators considering control modes and configurations of a microgrid,” *IEEE Trans. Power Del.*, vol. 25, no. 3, pp. 2007–2016, Jul. 2010.
- [9] R. H. Lasseter. Control and design of microgrid components. PSERC. Final Project Reports, 2006. [Online]. Available: http://pserc.wisc.edu/documents/publications/reports/2006_reports/lasseter_microgrid_control_final_project_report.pdf
- [10] Y. A.-R. I. Mohamed and E. F. El-Saadany, “Adaptive decentralized droop controller to preserve power sharing stability of paralleled inverters in distributed generation microgrids,” *IEEE Trans. Power Electron.*, vol. 23, no. 6, pp. 2806–2816, Nov. 2008.
- [11] J. A. Pec, as Lopes, C. L. Moreira, and A. G. Madureira, “Defining control strategies for microgrids islanded operation,” *IEEE Trans. Power Syst.*, vol. 21, no. 2, pp. 916–924, May 2006.
- [12] J. M. Guerrero *et al.*, “Wireless-control strategy for parallel operation of distributed-generation inverters,” *IEEE Trans. Ind. Electron.*, vol. 53, no. 5, pp. 1461–1470, Oct. 2006.
- [13] J. He and Y. W. Li, “Analysis, design, and implementation of virtual impedance for power electronics interfaced distributed generation,” *IEEE Trans. Ind. Appl.*, vol. 47, no. 6, pp. 2525–2538, Nov./Dec. 2011.
- [14] J. He *et al.*, “An islanding microgrid power sharing approach using enhanced virtual impedance control scheme,” *IEEE Trans. Power Electron.*, vol. 28, no. 11, pp. 5272–5282, Nov. 2013.
- [15] U. Nutkani, P. C. Loh, P. Wang, and F. Blaabjerg, “Cost-prioritized droop schemes for autonomous AC microgrids,” *IEEE Trans. Power Electron.*, vol. 30, no. 2, pp. 1109–1119, Feb. 2015.
- [16] Y.-S. Kim, E.-S. Kim, and S.-I. Moon, “Frequency and voltage control strategy of standalone microgrids with high penetration of intermittent renewable generation systems,” *IEEE Trans. Power Syst.*, vol. 31, no. 1, pp. 718–728, Jan. 2016.

- [17]F. Katiraei, M. R. Iravani, and P. W. Lehn, “Micro-grid autonomous operation during and subsequent to islanding process,” *IEEE Trans. Power Del.*, vol. 20, no. 1, pp. 248–257, Jan. 2005.
- [18]F. Katiraei and M. R. Iravani, “Power management strategies for a microgrid with multiple distributed generation units,” *IEEE Trans. Power Syst.*, vol. 21, no. 4, pp. 1821–1831, Nov. 2006.
- [19]Ms. Priyanka D Gajare and Prof.Ajit P.” *Chaudhari Control strategy for distributed generation units through Power Sharing &Frequency Recovery*” Resincap Journal of Science and Engineering Volume 2, pp. 416-424 Issue 6 June 2018