

Online Exam For Visually Challenged Candidates Using Text-Voice-Text Technique

AmalaVincy.S¹, Karpagam.M², Sivasakthi.R³, Pavithra.R⁴
1,2,3,4 PSR Rengasamy College of Engineering for Women, Sivakasi, India

Abstract- Assessments square measure the basic structure obstruct for instructive advancement. Individual gets elevated to more significant level or finishes a course once they complete a few tests. eightieth of serious assessments in Asian nation square proportion of target kind. they commonly contain eight or ten ex gratia questions. Perusing questions all through assessments square measure amazingly vigorous for the visually impaired or semi daze people due to their confined perceivability. Being code engineers, we will in general hold obligation to help those people. I propose to build up an entire framework that comprehends of these issues continuously by perusing inquiries written in all through assessment. Indeed, even it peruses the objective answers. Sound are frequently tuned in for telephone. we will in general be utilized SAPI apparatus natural with the VB to change over content to sound. The framework is confirmed for its strength continuously. In any event, for future improvement we've thoughts to highlight voice orders actuated like —repeat, —next page, _stop 'and so forth we tend to trust our framework give the visually impaired people strength to handle their assessment associated issues continuously.

Keywords- Blind people, Earphone

I. INTRODUCTION

The development of the Internet, and specifically the Web, is as of now impact the manner in which science is educated and will without a doubt do as such to more prominent degree later on. In territories of training it offers a medium that can possibly be increasingly receptive to understudies. Electronic Examination framework could be utilized by means of Internet or intranet for overseeing understudy assessment. Later on dazzle people groups additionally can do online test like a typical human if Test can be taken utilizing a straightforward client PC, a voice instrument gadget for login, console and the insignificant condition is only a Web program, Here Questions and decision are through in Voice our venture is conveyed progressively. Denoting the test is done consequently and immediately; the personnel is helped from these, tedious obligations. Various adaptations of a similar inquiry can be created for various understudies. Tests can be taken whenever. Tests can be taken anyplace. Blinds can login the test utilizing their DOB check.

The Answer will be get from the client through voice. The outcomes likewise conveyed through voice. The imprints are consequently gathered, broke down, and disseminated for purposes like assessment of instructing and learning process. Right now people groups can get the information utilizing different interfaces. For example, one basic technique for the visually impaired individuals have been planned to utilize is by voice acknowledgment, that is which has a voice recording framework. Where the documents had recorded as of now in certain configuration, the visually impaired individuals ought to should hear the recorded substance in that recording framework dependent on along these lines they can without much of a stretch know the substance and learn in a favored manner and furthermore they can cooperate with that framework by giving their voice as an information. These regular methodology have been utilized for the visually impaired individuals to uncover their ability in different stages and to get contend with typical individuals through the assistance of numerous gadgets. For instance in iPhone there is an office which permits a visually impaired individuals to get collaborate with that gadget as a typical man. On the off chance that they contact any catch or the showcase alternative in the iPhone has been intended to respond when by giving voice yield. So a visor people can utilize all the office gave in that telephone (they can get to all the choices like an ordinary man perusing, visiting, SMS, Music, gushing... .. and so on.).

II. EXISTING SYSTEM

The assessment framework for blinds permits volunteers to compose tests for the benefit of visually impaired up-and-comers. Finding a capable individual to do the composition for them in the assessment lobby is no less a wellspring of strain for dazzle understudies than the issues made by their inability. Absence of essayists is specific delicate for dazzle understudies reading for a propelled degrees in colleges.

III. PROPOSED SYSTEM

Our framework is a finished answer for assessment arrangement of blinds . Indeed, even it peruses the goal answers. Sound can be tuned in for earphone. As a change I

decreased the quantity of switches for choice by consistent sound reiteration till answer gets chose. Assume we have extra changes to confirm the appropriate responses then it can make superfluous disarray. We utilized SAPI apparatus inbuilt with the Windows OS to change over content to sound. The framework will be checked for its effectiveness progressively. In any event, for future upgrade we have thoughts to include voice orders enacted like "read once more", "next page", „end" and so on. We trust our framework give the visually impaired individuals productivity to handle their assessment related issues continuous

MODULES:

Database Tier

Here information are put away as records in tables on the server side database.

Test framework information

This contains all inquiry data; all answer data, all courses data and courses ILO'S, these information are clarified as follows:

Enrollment Data

This information have all the voice instruments of the enrolled competitors.

Question information

This comprises of information records about inquiries, for example, question area, and inquiry type.

Answer information module

This comprises of information records about inquiry and its answers, for example, question number, question type, and the understudy answer.

Course and Courses ILOS

It comprises of information about courses, for example, courses name, courses clarification, courses term and course Intended Learning Outcomes.

Login information

This contains all arrangement data information, every single visually impaired up-and-comer with related voice apparatuses information. These data"s are clarified as follows:

Arrangement data

This comprises of information records about framework arrangement, for example, administrator data.

Daze applicant's information

This comprises of information records about blinds, for example, voice apparatuses to check daze Id, daze username, and daze secret phrase.

Address information

This comprises of information records about territory, for example, Village name, and area name, blind"s watchman address.

Test Preparation:

It is utilized to oversee and deal with the course questions, tests. It additionally contains the rationale behind teacher course connection, educator term connection, course-term connection and the report behind these relations. This rationale used to deal with all the data put away in the database about course-teacher connection, educator test connection. *A detail of that rationale is portrayed as follows:*

Include questions:

The educator initially could embed all the inquiries.

Make test:

The educator could make test by choosing the inquiries that additional previously.

Update test:

The educator could refresh the test that made previously.

Setting up and observing the framework:

It is utilized to set and handle the up-and-comer data which is nitty gritty as follows: The administrator login, he can embed or refresh candidate data. There are a few situations for that occasion. The administrator login and he can embed or refresh teacher data he can check for the educator first if the educator doesn't exist the director can make new teacher record by including educator information.

Assessment motor:

Assessment Engine contains the rationale utilized by the possibility to take test and shows the outcomes after they stop it. This rationale is portrayed as follows: The frameworks first match the fingers prints and confirm the competitor subtleties who have already register.

LITERATURE SURVEY

A. *Developing e-Examination Voice interface for Visually Impaired students in Open and Distance Learning Context* Father of the Church A. Azeta, Itorobong A. Inam, Olawande Daramola

It ought to be noted that studies by previous students on helpful technology (such because the one according during this article) for the visually impaired learners, have mostly targeted on the success stories in developed countries within the Western Europe and North America, wherever vital progress has been recorded [28] and [29], however, the standing of helpful technology within the developing countries in Africa, Jap Europe and Asia, principally highlights drawbacks in its implementation. Among the predominant obstacles to the winning implementation of voice-based inclusive education for the visually impaired includes inadequate funding, meager trained academics and support employees, governmental support, ineffective policies and legislation, political instability, and depression. These are a number of the restrictions of the study that might get to be self-addressed, for winning preparation of the voice-based e-examination skilled system for the visually impaired.

In this paper, associate e-examination voice interface for the visually impaired learners in ODL has been provided. The developed system was completed employing a framework, system style with pseudocode dialogue sequence and algorithmic rule. A usability analysis of the system was additionally conducted. The voice-based examination system would improve the accessibility of examination in distance learning for learners with impairment, moreover as different fit learners.

B. *on-line Examination for sand-blind individuals* J.Kanimozhi, A.Karkuzhali and K.Suresh kumar

By means that of once you that these risks information superhighway examination may take location through input device technology. At constant time the matter content given because the enter by means that of the cellular mobile the matter content send to microcontroller via utilizing the Bluetooth. The question are indiscriminately given to the candidate. The microcontroller ship the matter content to the

voice board which will covert the text to voice. The voice hear by means that of the blind individuals by method of the top radiophone. once taking note of the question the solution press by means that of the blind men and girls exploitation input device. The question repeat double at intervals the earphone. The temporal order buzzer has been set to point the question time for the only question. For single question the indication are given by the temporal order buzzer. The one or two of possibility are given to the blind men and girls for responsive once responsive the reply are hold on at intervals the server for future motive.

C. *Developing audio tactile for visually impaired students* Janu ARLINWIBOWO, Dr. Heri RETNAWATI

The aim of this study is to develop teaching materials supported Audio Tactile that is valid, practical, and effective to enhance learning motivation and accomplishment of visually impaired students. This study was an exploration and development (R&D). the information assortment techniques during this analysis were observation, interview, documentation, and tests. This analysis used a qualitative approach as an information analysis technique. The conclusions of this study were the merchandise developed as a collection of audio tactile teaching materials that consisted of learning audio sources and tactile media. These audio teaching materials were supported by many tactile media like planes, puzzle, geoboard, tactile rules, and tactile protactor. The Audio Tactile teaching materials will improve learning motivation of visually impairment students. the rise of learning motivation was indicated by high student's can to check, student's high preservice, student's enjoyment, and curiosity. The Audio tactile teaching materials gave nice positive impacts on learning achievements. this is often shown by the increasing score of posttests compared to the score of pretests.

IV. DISCUSSION

A.SCOPE

Voice-based frameworks permit clients access to data on the web over a voice interface. Earlier investigations on Open and Distance Learning (ODL) assessment frameworks that utilize voice interface don't adequately show smart type of appraisal, which lessens the thoroughness of assessment. The goal of this paper is to enhance the accomplishments of past investigations by giving a structure that will control the advancement of a voice-based e-assessment master framework for the outwardly debilitated understudies in ODL. The examination utilizes a blend of advances, for example, framework structure, server-side scripting, voice-based

framework improvement, information the board and rule-based thinking in building up the framework. The framework was assessed to decide the degree of convenience. The consequences of the ease of use assessment demonstrated that the created application has a 'normal ease of use' rating of 3.48 out of 5 scales. The discoveries show that the voice-based e-assessment framework won't just be of tremendous advantage to the outwardly debilitated understudies in ODL in particular of separation, however will likewise supplement the current electronic strategy for online assessment

B.SYSTEM DESIGN

The test will be taken on this apparatus in following advances:

1. The client is furnished with the equipment hardware for example Earphone and mouthpiece, and with the framework.
2. Authenticate User's Login by approving the Thumb Impression- - Save some Thumb impressions as of now in the framework or the product and utilize these impressions for approval without utilizing Biometric Device.
3. Create a manager who will deal with all the data of the client. He can make client's record, erase and see the client's test outcomes.
4. Programming Working ought to resemble
 - The client stands up his name and afterward he is approved by his thumb impression.
 - System will invite the client by saying Welcome xyz.
 - User will give the guidance for beginning the test and the test ought to begin.
 - Text to discourse programming working at the Backend will take an irregular inquiry from the SQL Database and stand up the inquiry with the choices to the client.
 - The client will at that point stand up one alternative which will be initiated by the discourse to content programming working at the backend.
 - When client says Next framework should move to the following inquiry and when he says Finish the framework should stop the test. A recurrent alternative ought to likewise be included so that if the client doesn't listen appropriately to the inquiry first time, the person has a choice to rehash it.
 - A clock for the entire test ought to be set for explicit time. After that time the test should end naturally.
 - The Result of the test is then produced and spared in the client's database and furthermore the outcome is stood up to the client.

System Architecture:

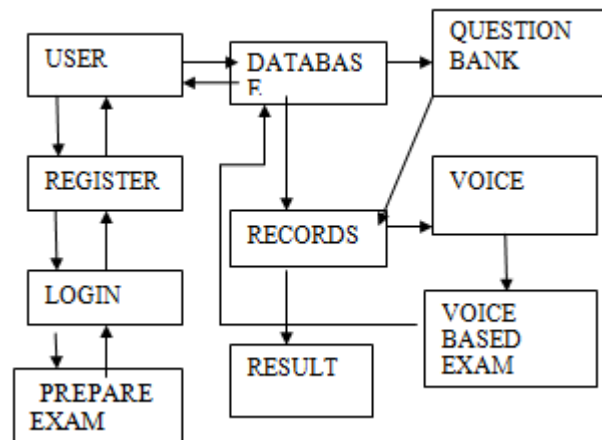

V. CONCLUSION

Learning is significant for everybody and it is similarly critical to give a similar learning chances to extraordinary requirements individuals, for example, the individuals who are outwardly disabled. Edutainment applications are generally utilized by educators and they are powerful learning apparatuses that make learning new things fun. Be that as it may, because of rich media association in edutainment and absence of connection, the utilization of edutainment application by the outwardly disabled in their learning procedure is low. Lion's share of the members concurred that the application is valuable in learning and urges them to complete learning in a virtual situation. Moreover, they additionally concurred that the application is basic and simple to utilize and require least strides to achieve the errands. Be that as it may, some of them required a specialized individual to help them in utilizing the application. It could be because of them not having been presented to a haptic gadget previously. In any case, they figured out how to utilize the application rapidly and recalled how to utilize the application without any problem. Most of the members concurred that the application is enjoyable to utilize, and they would prescribe the application to their kindred companions. Taking everything into account, the proposed application can be utilized in a virtual domain for outwardly impeded clients in their learning procedure.

VI. ACKNOWLEDGMENT

I take her chance to precise my hearty due to my guide faculty member. **Pavithra.R** for his steering and sharing her findings for technical steering and direction. Suggestions given by her were forever useful during this work to succeed.

Her leadership has been greatly valuable on behalf of me to figure on this project and is available with the best out of it.

REFERENCES

- [1] Brooks, D. W. "Web-teaching: a guide to designing interactive teaching for the World Wide Web". 1997, New York: Plenum Press.
- [2] De La Beaujardiere, J. F., Cavallo, J., Hasler, A. F., Mitchell, H., O'Handley, C., Shiri, R., & White, R. "The GLOBE Visualization Project: Using WWW in the Classroom." , Journal of Science Education and Technology, 6(1), 15-22, 1997.
- [3] Khan, B. H. (Ed.). "Web-based instruction", Englewood Cliffs, N.J.: Educational Technology Publications, 1997.
- [4] I. Hernán-Losada , C. Pareja-Flores, and J. Velázquez-Iturbide, "Testing- Based Automatic Grading: A Proposal from Bloom's Taxonomy", Eighth IEEE International Conference on Advanced Learning Technologies, 2008.
- [5] W. Huang, X. He, and Lin Qiao, "The Design and Implementation of Web-based E-learning Examination System Based on J2EE ", Proceedings of the International Conference on Information Technology, 2004 IEEE.
- [6] Yuan Zhenming¹, Zhang Liang², Zhan Guohua³ , " A novel Web-Based online examination system for computer science education " , 33rd ASEE/IEEE Frontiers in Education Conference , 2003.
- [7] S. Bonham, A. Titus, R. Beichner and L. Martin, " Education research using web-based assessment systems " , Journal of Research on Computing in Education, Fall 2000.
- [8] Allen, I. E. & Seaman, J. Sizing the opportunity: The quality and extent of online education in the United States , 2002 and 2003. The Sloan Consortium, Needham , Massachusetts . Retrieved February 12, 2004 from <http://www.sloan-c.org>, 2003
- [9] Harvey J and Mogy N (1999) Pragmatic issues when integrating technology into the assessment of students. In Brown S, Race, P & Bull J (1999) Eds), Computer – assisted assessment in higher education London: Kogan – Page.
- [10] A. Rickett D. Pullen and C. Harpers Case study of a computer based examination system Australian Journal of Educational Technology 25(4) , pg 509-523, 2009.
- [11] Engelbrecht, J. and Harding A. Combining online and paper assessment in a web-based course in undergraduate mathematics. Journal of Computers in Mathematics and Science Teaching, 23,(3), 217-231, 2003.
- [12] Pullen D and Cusack B Content Management systems ; The potential for open education Fact Sheet, FS01, Australian College of Educators, Canberra 2008.

AUTHERS



Marjan Mansourvar is presently a Ph.D. candidate and lookup assistant in the Department of Computer Science and Information Technology at the University of Malaya (UM), Malaysia. She acquired her M.Sc. in Information System in 2010 from the University of Malaya underneath the supervision of Dr. Norizan Binti Mohd Yasin and BE (Software Engineering) in 2005 from Iran. She labored in ParsaGostar, Iran as a software program developer and participated in several ICT tasks from 2003 until 2007. She is a member of the IEEE society and can be corresponded by using marjan2012@siswa.um.edu.my.



Norizan Binti Mohd Yasin is a senior lecturer at the Department of Information System, Faculty of Computer Science and Information Technology at the University of Malaya, Malaysia. She has been actively working in the areas of Information System Application. Her educational skills had been bought from UK universities – bachelor and grasp tiers from the University of Miami (USA), and Ph.D. from Manchester University, United Kingdom.