

# A Review And Taxonomy on 802.16 WiMAX Systems

Neha Mawar<sup>1</sup>, Prof. Jitendra Singh Dodiya<sup>2</sup>, Prof. Vijay Bisen<sup>3</sup>

<sup>1</sup>Dept of EC

<sup>2,3</sup> Assistant Professor, Dept of EC

<sup>1,2</sup> VITM Indore (M.P.)

**Abstract-** WiMAX (Worldwide Interoperability for Microwave Access) has evolved as one of the most effective techniques for providing last mile connectivity for Wireless Systems. It is a technology which is developed to promote and certify interoperability and compatibility of broadband wireless access and standardizes as IEEE 802.16. The WiMAX is very similar to Wi-Fi but it provide higher data rates compared to Wi-Fi and also it can be used over greater distances and for greater number of customers. There are several features of WiMAX that are responsible for the effectiveness of WiMAX systems. This paper introduces the fundamentals of the system with previous work done on the system.

**Keywords-** WiMAX, Orthogonal Frequency Division Multiplexing (OFDM), Bit Error Rate (BER), Probability of Error ( $P_e$ )

## I. INTRODUCTION

As we know that the demand of internet access and cellular services are increasing day by day. The wireless communication is needed for transmitting and receiving data at long distances. For the communication some standards are required which helps to transfer data at high data rates and also provide coverage and mobility in the communication. [3] Broadband wireless access is very popular in now a day and replaced the long distance cable and DSL connections. There are two important IEEE standards one is for Local Area Network (LAN) as 802.11 and the second is Metropolitan Area Network (MAN) as 802.16 which is generally known as WiMAX. These wireless communication standards are useful for the fixed broadband wireless access for the rural as well as urban areas and mobility so that these can be used with the portable devices like cell phones.

WiMAX (Worldwide Interoperability for Microwave Access) is a very popular and important broadband wireless technology today. This technology is mainly used to provide broadband access services to the residential and commercial areas in an economical way. It is a technology which is developed to promote and certify interoperability and compatibility of broadband wireless access and standardizes as IEEE 802.16. [13] The WiMAX is very similar to Wi-Fi but it provide higher data rates compared to Wi-Fi and also it can be

used over greater distances and for greater number of customers.

WiMAX was introduced in the world in April 2001 and specified as 10-66 GHz IEEE 802.16. WiMAX is standardized as 802.16 as the Wi-Fi (802.11). The standardization provides the compatibility for the equipment manufacturing which uses WiMAX. [7] There are basically two usage models of the IEEE 802.16 as:

1. A fixed usage model (IEEE 802.16-2004).
2. A portable usage model (IEEE 802.16e-2005).

## II. MATHEMATICAL MODELING OF BER FOR WIMAX SYSTEMS:

The probability of error ( $P_e$ ) or Bit Error Rate (**BER**) is defined by[21]:

$$P_e = P(0)P(1/0) + P(1)P(0/1) \quad (1)$$

Provided that system is assumed to be affected only by white noise than

$$\begin{aligned} P(1/0) &= P(0/1) \\ \text{So, } P_e &= P(1/0)[P(0) + P(1)] \\ P_e &= P(1/0)_{\text{Or}} P(0/1) \\ P_e &= \int_{v_{\text{th}}}^{\infty} f(z/0) dz \\ &= \int_{v_{\text{th}}}^{\infty} \frac{1}{\sqrt{2\pi\sigma_{n_0}^2}} e^{\left(\frac{-(z-a_z)^2}{\sigma_{n_0}^2}\right)} dz \end{aligned}$$

Assume  $\frac{z-a_z}{\sigma_{n_0}} = y, z - a_z = y \cdot \sigma_{n_0}$

Differentiating above equation we get,

$$dz = \sigma_{n_0} dy$$

For  $z \rightarrow \infty, y \rightarrow \infty$  and  $z = V_{th}, y = (V_{th} - a_2) / \sigma_{n_0}$

$$y = \frac{a_1 + a_2}{2} - a_2$$

$$y = \frac{a_1 - a_2}{2\sigma_{n_0}} \quad (2)$$

Utilizing the Q-function,

$$Q(x) = \frac{1}{\sqrt{2\pi}} \int_x^\infty e^{-\frac{y^2}{2}} dy \quad (3)$$

Where y = a dummy variable.

Thus, probability of error can be expressed as

$$P_e = \frac{1}{\sqrt{2\pi\sigma_{n_0}^2}} \int_{\frac{a_1 - a_2}{2\sigma_{n_0}}}^\infty e^{(-y^2/2)} \sigma_{n_0} dy \quad (4)$$

In terms of Q-function, probability of error can be expressed as

$$P_e = Q \left[ \frac{a_1 - a_2}{2\sigma_{n_0}} \right] \quad (5)$$

In case of matched filter,  $P_e$  is given as

$$P_e = Q \left[ \sqrt{\frac{(a_1 - a_2)^2}{4\sigma_{n_0}^2}} \right] \quad (6)$$

When more than one signal is transferred through the matched filter then  $h(t) = x(\tau - t)$  where  $x(t) = x_1(t) - x_2(t)$  then  $\frac{(a_1 - a_2)^2}{\sigma_{n_0}^2}$

corresponds to its maximum possible of  $\frac{E_D}{N_0}$ , so that  $P_e$  corresponds to its minimum possible.

$$P_e = Q \left[ \sqrt{\frac{1}{4} \frac{E_D}{N_0}} \right] \quad (7)$$

Where  $E_D$  is energy of x (t). Thus in terms of signal power to

noise power,  $P_e$  can be expressed as  $P_e = Q \left[ \sqrt{\frac{S}{N}} \right]$

Where S = signal power =  $E_D/4$ , N = noise power =  $N_0 \times$  Band width

It is important to note that BER degradation occurs due to the random frequency selective nature of wireless channels. Hence if it is made possible to provide with the channel response, then the sub-carriers with weak signal strength can be discarded that would result in improved BER performance of the system.

### III. IMPLEMENTATION OF WiMax SYSTEMS

The block diagram of WiMAX transceiver is shown below. The implementation of the WiMAX system relies on the modulation format, use of IFFT and PPF blocks to generate mutually orthogonal sub carriers. Addition of cyclic prefix results in nullification of Inter Symbol Interference (ISI). Channel equalization is also effective in reducing the Bit Error Rate (BER), Probability of Error ( $P_e$ ) of the system.

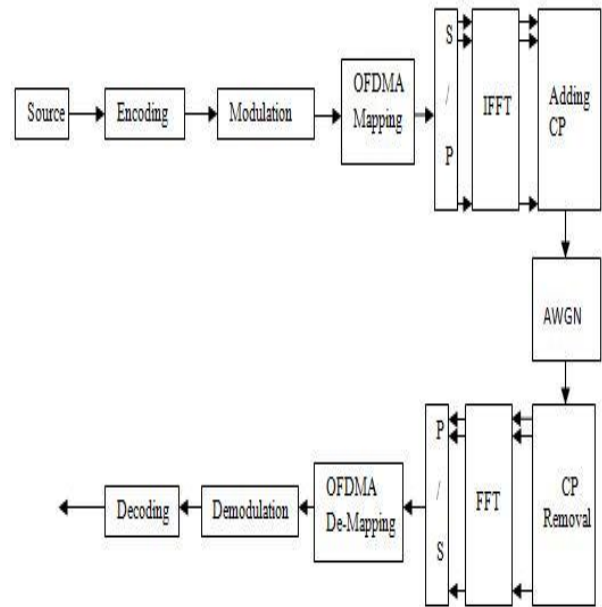

Fig.1 Block Diagram of WiMAX Transceiver[7]

The implementation of the WiMAX system relies on the modulation format, use of IFFT and PPF blocks to generate mutually orthogonal sub carriers. Addition of cyclic prefix results in nullification of Inter Symbol Interference (ISI). Channel equalization is also effective in reducing the Bit Error Rate (BER), Probability of Error ( $P_e$ ) of the system.

### IV. PREVIOUS WORK

In [1], Mukesh Patidar et.al discussed the modeling of the physical layer of the WiMAX. It was critical for the calculation of the BER and evaluation the real time audio data under different channel encoding rate, digital modulation schemes and channel conditions. The receiver and transmitter

is also simulated according to the standard parameters. The convolution coding is also used to improve the performance of the system. The analysis is done through the evaluation of the bit loss and the packet loss over the channel during the transmission.

In [2] Octavia A. Dobre et.al developed the mathematical models of the OFDM-based mobile Worldwide Interoperability for Microwave Access (WiMAX) and third-Generation Partnership Project Long Term Evolution (3GPP LTE) signals and also studied the second-order cyclostationarity. An algorithm is proposed for the cyclic autocorrelation function (CAF) and cycle frequencies (CFs). The proposed algorithm is immune to phase, frequency, and timing offsets and did not required carrier, waveform, and symbol timing recovery.

In [3] ZeyadMoh. Elkwash et.al implemented a WiMAX system with the help of MATLAB tool. The results of simulation are useful to evaluate the BER of different modulation techniques (BPSK, 4QAM, 16QAM, and 64QAM) by the effect of CP. The simulation is based on the variation in gain vector, delay vector, and signal to noise ratio (SNR). From the results the smallest value of the BER is given by the comparison of the specified values of the cyclic prefix, gain vector, delay vector, and modulation technique. These all values provide the evaluation in the performance of the WiMAX communication.

In [4] Lakshmi Boppana et.al presented a very reliable adaptive modulation coding technique for maximization of the throughput and target BER. For the given value of the threshold an efficient coding technique is proposed by the authors. In the work the authors accept the parameter values like SNR, BER, CINR, BLER channel attenuation factor and then select the modulation schemes with an appropriate coding rate for the OFDM system operation in the GNU Radio.

In [5] B. Siva Kumar Reddy et.al proposed a selection strategy incorporated with the GNU Radio which determines the modulation and coding schemes (MCS) with the help of parameter estimation over AWGN and Rayleigh fading. The variation in the channel model and FFT size provides the different values of threshold for the choice of MCS. By changing the number of the bits for every byte and modulation scheme in the GNU Radio companion over AWGN and Binary symmetric channels with the help of Convolutional coder, RMG (Reed-Muller-Golay) coder and RM (Reed-Muller) coders were investigated for the BER (Bit Error Rate) execution of WiMAX physical layer. The paper

provides various analyses of the 2x2 MIMO frameworks under the Convolutional code rates and digital modulations.

In [6] BenzartiMajdi et al used the Schmidl and Cox algorithm which is a symbol timing algorithm of the OFDM system. The paper also provides some preamble mathematical concept according to 802.16d. with the help of the simulation results is based on the performance of the carrier frequency offset (CFO) and timing frequency offset (STO) in a WiMAX context on the OFDM system.

In [8] Umang R et.al introduced the next generation MIMO systems like LTE 8, Advance LTE 10, IEEE 802.16e, IEEE 802.16m with the standardize process like relay technology. The most commonly used technologies of today are WiMAX and the LTE. Both of the technologies are based on the IEEE standard. They are almost same but differ only in the manner of the deployment. In this paper authors discuss about the both of the technologies in the physical layer. The analysis of different modulation schemes is also given the paper.

In [9] Monika Cheema et.al proposed MIMO systems to be used in WiMAX systems. The technique uses the smart antenna which has spatial transmit diversity and spatial multiplexing (SM). With the help of Alamoutis Space Time coding, Spatial transmit diversity is achieved. Low-Density Parity- Check (LDPC) codes are very popular for the minimum error rate of high capacity signals. The codes are generally known as Tanner graph. This graph degrades the performance of the LDPC and has short cycles. The paper proposed the channel coding method named as Quasi Cyclic (QC) LDPC. For a strong diversity gain STBC is used as a MIMO technique. The results presented the MIMO OFDM physical layer in WiMAX with the use of LDPC under different digital modulation techniques.

In [10] Lavish Kansal et al proposed spectral efficiency estimation of discrete Fourier transform (DFT) based WiMAX structure and discrete wavelet transform (DWT) based WiMAX. The authors validated the evaluation over Rayleigh channel with the help of divergent digital modulation levels along by diverse convolution code (CC) rate proposed for FFT-WiMAX and WHT-WiMAX. The structure which is simulated is investigated with the help of the BER and spectral efficiency which is a function of the signal to noise ratio. A better BER and spectral efficiency improvement for the given value of SNR is found by the simulation with the help of WHT-WiMAX in comparison to FFT-WiMAX.

In [11] Sayali R et.al proposed paper the wavelet packet modulation in WiMAX. The simulation results provide the the performance of the BER is better than the OFDM which uses cyclic prefix and consequently has higher SNR. The results are studied over the AWGN channel and frequency selective Rayleigh channel. The plots of BER performance of different Wavelet families for the channel conditions are also proposed.

In [12] Goran T. Djordjevic et.al proposed a technique to determine the overall error rate, for which a mixed FSO/WiMAX link is used. The authors provide the error rate dependence on different system and parameters of channel. The observation of the effects of FSO and RF channel is studied. The authors also suggest some quasi cyclic low-density parity-check (LDPC) codes which is very useful for the implementation of such systems. The analysis of the error rate performance for different code words lengths is also done.

In [13] Hardeep Kaur et.al presented simulation results provide the analysis of the Bit Error Rate (BER) for ITU-R and Cost- 207 channel model conditions for Typical Urban (TU) Area and Typical Rural Area (RA). The result shows that the BER of QPSK is less than the QAM-16. It is discussed that the performance of the Pedestrian-A channel is better than the Vehicular-B channel. It is also concluded that the Cost-201 channel model is simulated and TU channel model gives improved performance than RA.

## V. CONCLUSION

It can be concluded from previous discussions that all the research conducted earlier recognized WiMAX as an effective technique for rendering high speed last mile connectivity with satisfactory Quality of Service (QoS). Also high data rates are possible due to the use of Orthogonal Frequency Division Multiplexing (OFDM). From the recent research, it can be seen that the latest trends in this technology is focusing on BER improvement of WiMAX systems have been done using several different approaches. The salient features of the different techniques has been summarized in the paper.

## REFERENCES

[1] Simulating the WiMAX Physical Layer in Rayleigh Fading Channel, Scientific and Academic Publishing, 2011.

- [2] “Performance Analysis of WiMAX 802.16e Physical Layer Model”, MukeshPatidar, Rupeshdubey, Nitin kumar Jain, Saritakulpariya, year 2012 IEEE.
- [3] “Second-Order Cyclostationarity of Mobile WiMAX and LTE OFDM Signals and Application to Spectrum Awareness in Cognitive Radio Systems”, Ala’a Al-Habashna and Octavia A. Dobre, year 2012 IEEE.
- [4] “Effect of Cyclic Prefix on Data Rates in WiMAX System with Variation in Delay Vector, Gain Vector, Signal to Noise Ratio and Coding Rates for Different Modulation Techniques”, ZeyadMoh. Elkwash, Nafaa M. Shebani, Mohammed A. Mjehed, AbdulHamid M. Masoud and Rabea M. Elmareymi, year 2013 IEEE.
- [5] “Coding Rates and MCS using Adaptive Modulation for WiMAX in OFDM Systems using GNU Radio”, Lakshmi Boppana, Chandana N. Amanchi and Ravi Kishore Kodali, year 2013 IEEE.
- [6] “Adaptive Modulation Coding in MIMO-OFDM for WiMAX using GNU Radio”, B. Siva Kumar Reddy and Lakshmi Boppana, year 2014 IEEE.
- [7] “A Physical Layer Simulation for WiMAX MIMO-OFDM System”, HadjZerrouki and Mohammed Feham, year 2014 IEEE.
- [8] “Optimization of ber performance in the mimo-ofdma system for mobile WiMAX system using different equalization algorithms”, Azlina Idris, Norhayati Abdullah, Nor Azlizan Hussein and DarmawatyMd Ali, year 2015 APRN journal.
- [9] “Wimax timing and frequency synchronization based on training sequence”, Benzarti Majdi1, Messaoudi Mohamed and Hasnaoui Salem, year 2015 IEEE.
- [10] “Performance Comparison of Different Modulation Schemes in Advanced Technologies WiMAX and LTE”, Umang R. Mori, Parth M. Chandarana, Gunjan V. Gajjar and Shivakrishnadasi, year 2015 IEEE.
- [11] “Analysis of MIMO OFDM Based WiMAX System with LDPC”, Monika Cheema and Sukanya A kulkarni, year 2015 IEEE.
- [12] “Performance evaluation of FFT-WiMAX against WHT-WiMAX over Rayleigh fading channel”, Lavish Kansal, Vishal Sharma and Jagjit Singh, year 2016 Elsevier.
- [13] “BER performance of WIMAX system using wavelet packet modulation technique”, Sayali R. Band, Megha S. Dorle and Dr. S. S. Dorle, year 2016 IEEE.
- [14] “BER Analysis of WiMAX on FSO”, Goran T. Djordjevic, and Ivan B. Djordjevic, year 2016 IEEE.
- [15] “Performance Analysis of Mobile WiMax for Frequency Selective Fading Channel Models”, Hardeep Kaur and M.L. Singh, year 2016 IEEE.  
<https://www.dsprelated.com/showarticle/> A Beginners Guide to OFDM

[16] Wireless Communication by Andreas Molisch, Wiley  
India.