

Automatic Star Delta Starter Using Relay And Adjustable Electronic Timer For 3 Phase Induction Motor

M.Hareesh¹, M.Tech Venkatrao²

²Asst.Professor

^{1,2}Svpct,Putturs

Abstract- We all know that three phase induction motors draw high value of current during its starting operation as compared to un full load running conditions.

Various methods have been developed over years for starting these induction motors with low value of current to reduce the effects of high starting current and the complex starting methods to reduce starting current is often compromised with other unanticipated inrush currents introduced by the starting system itself . This project implements the use of relays and electronic timer which provides low current start to the motor and protects it from inrush currents as well.

Keywords- Three Phase Induction Motor, Reduce Starting Current, low current start.

I. INTRODUCTION

Three phase induction motors are widely used due to their low cost, rugged construction, fast pickup, low maintenance and high efficiency. The direct online starters don't provide sufficient protections against voltage fluctuation and single phasing while induction motors are highly sensitive to these. Induction motors if not switched to delta mode of operation within a few seconds then motor can draw heavy current and burn out itself so a sensitive protection and switching device are needed to avoid such conditions and protect the motor. For this purpose we use automatic star delta starters with relays and electronic timer with the help of which we can switch the mode of operation of the motor from star mode drawing low current to delta mode drawing the full load current. This will used for best protection of motor against high current. This method also having single phasing protection. Starting current having high value of current hen after to reduce this high current.

II. METHOD

The automatic star delta starter using relays and microcontroller as timer device is a standalone system that is capable of switching the motor from star to delta mode of operation to keeping the system functioning properly. We receive three single phase ac power supply through three 230/12 volts single phase step down transformers. This is converted to 12 v dc through three set of bridge rectifiers. One of these outputs is fed to 7805 voltage regulator which provides 5 volt dc input for the working of microcontroller. The other two sets of 12 volt dc output are used to drive the two relays.

The lamps which represent the three phases of windings of the motor are directly connected to the 230 volt power supply through the two relays one in star configuration and other in delta configuration.

III. EQUATION OF STAR-DELTA CONNECTION

A) STAR CONNECTION:-

Phase Voltage $V_s = 3$ Phase Voltage

$$= V_1 \times 1/\sqrt{3}$$

Phase Current $I_{S1} = \text{Phase Voltage } V_s / Z$

$$= \sqrt{3} \times V_1 / 3Z \text{ Line Current} = \text{Phase Current } I_{S1} \\ = \sqrt{3} \times V_1 / 3Z$$

B) DELTA CONNECTION:-

Per Phase Voltage $V_s = 3$ Phase Voltage V_1 Phase Current $I_{S2} = \text{Phase Voltage } V_s / z$
 $= V_1 / Z$

$$\text{Line Current} = \sqrt{3} \times \text{Phase Current } I_{S2}$$

$$= \sqrt{3} \times V_1 / 3Z$$

IV. BLOCK DIAGRAM

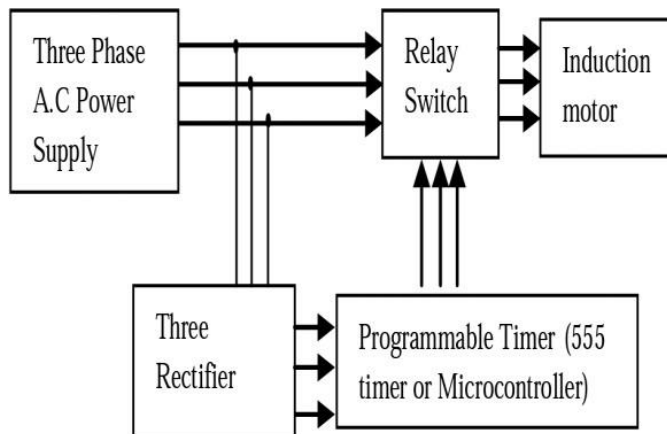

Fig.1.0: The automatic induction motor starter with programmable timer

In given above block diagram firstly Three phase supply 415V AC is given to the three single phase transformer 230/12 Volts output from one of these transformers is supplied to the Printed Circuit Board through three sets of bridge rectifiers to operate the 12 Volt DC relays. It is also used to run the microcontroller 89C 2051 through the 7805 Voltage regulator which gives an output of 5volt DC output from other two transformers are used to operate the star and delta connected relays which operate with a time delay of 3 second set by the microcontroller. This changes the operation of motor from star mode in the starting to delta mode after the fixed time delay. It operates the motor windings from the high inrush current during starting of the motor and allows only $1/\sqrt{3}$ of the rated current. After the fixed time delay the motor is switched to delta mode of operation allowing full load current. This protects the motor winding from any damage.

V. RESULTS AND DISCUSSIONS

First our project starts in star configuration in which $v/\text{root } 3$ voltage is supplied to lamp. This is expressed as lamp glows dim. Since we are using automatic timer configuration is automatically converted to delta, In which rated voltage is supplied to lamp which results full voltage

supply to lamps. So as a result lamp glows brighter in delta configuration.

230 volt ac supply is supplied to step down transformer, which converts 230 volt ac supply into 12 volt dc. 12 volt dc supply is supplied to bridge rectifier and filters which provide regulated 12 volt dc supply. This 12 volt dc supply is supplied to relays and microcontroller which switches star configuration to delta configuration.

VI. DESIGN OR IMPLEMENTATION

The initially paper design and implementation of this project is given below:-

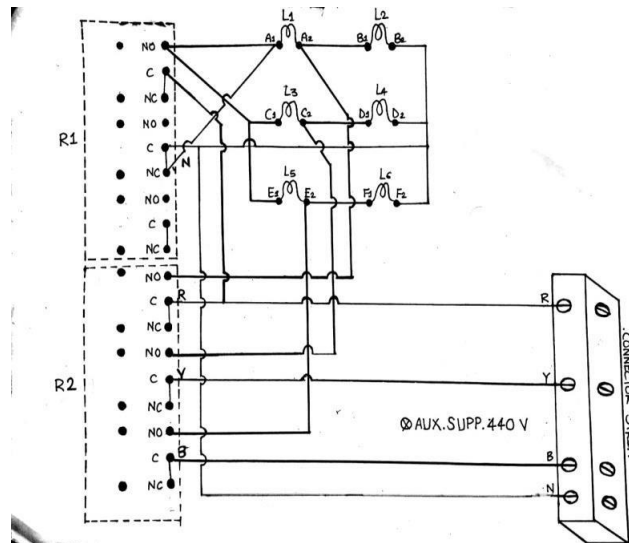

VII. PROCEDURE

- STEP1- First of all the supply 415Volt 3 phase 50Hz AC supply is given to the circuit and MCB provided in the circuit is switched on.
- STEP2- We observe that the lamps glow dim because of the less starting current in the star mode of operation.
- STEP3- After 3 second the timer will give instruction to the relay to switch the mode of operation from star to delta.
- STEP4- The delta mode of operation we observe that the lamps glow bright due to the rated current flow in the circuit.
- STEP5- The current and voltage during both the star and delta mode of operation are measure by digital multi meter.
- STEP56- After taking all the readings the miniature circuit breaker is turned off and then the main supply is cut off.

VIII. CONCLUSION

As we have performed this project we can conclude that this type of starting is used for low to medium voltage applications. It is the cheapest way to reduce the starting current for three phase induction motors as it is in the order of three to four times that in case of direct online starter. By this project we can conclude that this method of starting the motor can be easily implemented with the help of relays and the electronic timer circuit.

The way of connecting the relays gives prevention of the motor from the single phasing. It has been implemented by the using of induction motor starter but here in our project we are using six lamps instead of induction motor. Star- delta starter are also used by Direct On Line method but by automatic star delta starter they will be switched from one mode to other automatically by the use of adjustable electronic timer. Initially Timer will set a finite no. of second to switch over from star to delta operation mode. Basically the main advantages of this method is to protect the motor of high starting current but in DOL method motor will not be protected well. The display of the monitored voltage is easily indicated by the difference in the glow of lamps.

REFERENCE

- [1] Ashfaq Hussain, Electric machines , 2nd edition , Dhanpat rai & co.
- [2] BL Thareja, Electrical machines, vol 1 &2
- [3] www.electrical4u.com
- [4] www.nptel.ac.in
- [5] <https://www.scribd.com>
- [6] The 8051 microcontroller and embedded system by Muhammad Ali mazidi
- [7] Design of electrical machines by AK Shawney. 28:761