

Heart Beat Monitoring System By Using IOT

Ramamuneppagaru Prema ¹, T.Bathina Babu ²

¹Dept of ECE

²Assistant Professor, Dept of ECE

^{1,2} Seshachala Institute Of Technology,Puttur.

Abstract- *The objective of this project is to demonstrate how internet of things (IoT) is transforming healthcare and the role of IoT in healthcare. The applications of IoT are nowhere essential in transforming lives of people than in healthcare. IoT refers to physical devices, such as a weight scale, thermometer and patients' vital monitoring devices (temperature, blood pressure, heart rate & activity monitoring, etc.) connect to the internet and transforms information from the physical world into the digital world.*

The aim of the project is to provide a better health care to people in house in more economic and pertinent friendly manner. The need of home-based health monitoring system is increased now-a-days because health care cost is increasing exponentially in last few decades. In the proposed IoT based health care monitoring system using android smart phone includes the aspects of acquisition of medical parameters like Body temperature, Pulse rate. Processing of a collected data using ATmega328p processer and processed data is then displayed on doctors or relatives android mobile phones. Also, the data can be displayed on a personal computer.

I. INTRODUCTION

The main objective of the designed system is to have continuous monitoring of the patients over internet.

Today Internet has become one of the important part of our daily life. It has changed how people live, work, play and learn. Internet serves for many purpose education, finance, Business, Industries, Entertainment, Social Networking, Shopping, E-Commerce etc.

The next new mega trend of Internet is Internet of Things (IoT). Visualizing a world where several objects can sense, communicate and share information over a Private Internet Protocol (IP) or Public Networks. The interconnected objects collect the data at regular intervals, analyses and used to initiate required action, providing an intelligent network for analysing, planning and decision making.

This is the world of the Internet of Things (IoT). The IoT is generally considered as connecting objects to the Internet and using that connection for control of those objects or remote monitoring.

II. EXISTING SYSTEM

In social insurance framework for patients who stays in home during post operational days checking is done either through overseer/ medical caretaker. Ceaseless observing may not be accomplished by this system, on the grounds that anything can change in wellbeing parameter inside of part of seconds and amid that time if guardian/attendant is not in the premises causes more noteworthy harm.

So, with this innovation created period where web administers gives a thought to add to another keen health awareness framework where time to time constant checking of the patient is accomplished.

Unlike most of the existing methods there are many wireless technologies are available to monitor but the range of distance is limited. In this, we are using IoT for monitoring. In IoT there is no limit to distance. We can monitor patient heart beat and temperature form anywhere through internet.

III. PROPOSED SYSTEM

In the proposed system, our approach is to monitor real time heart rate through cloud. The collected heart rate can be stored and analysed in real time through an IoT technology for prognosis and diagnosis. The proposed hardware system consists of a single chip Arduino microcontroller embedded with GPRS to connect internet. The results demonstrated that the proposed system could be comparable to medical grade devices. By using thinks peak server account we can analyse those signals directly in our mobile phone using internet at anywhere from the world.

IV. BLOCK DIAGRAM OF PROPOSED SYSTEM

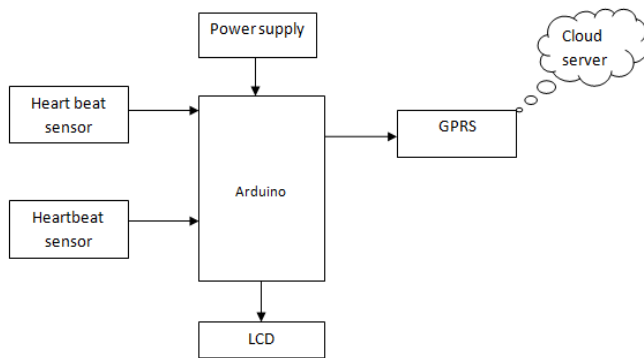

Block diagram of Proposed system

Block diagram of the proposed system consists of 5 blocks. Heart beat sensors, Power supply, LCD, Arduino microcontroller, GPRS. Power supply board provides power to the all the components. Arduino microcontroller takes data from the heart beat sensors, process the data and upload it to the cloud using GPRS. Heart beat rate (in BPM) is also displayed on the LCD.

V. CIRCUIT DIAGRAM OF THE PROPOSED SYSTEM

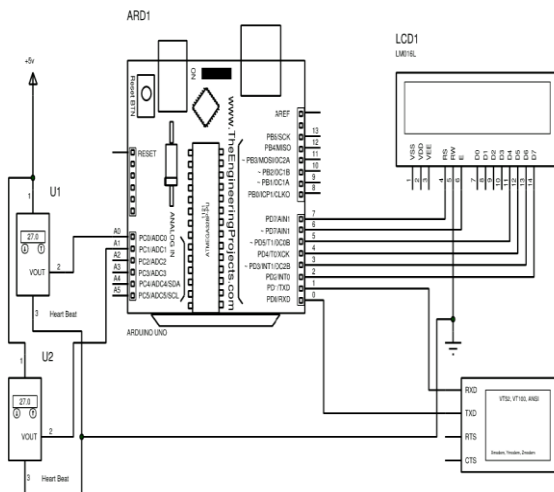

Circuit Diagram of the Proposed System

Operation of the Circuit:

The working of this project is quite simple and easily understandable. Upload the code to Arduino UNO and Power on the system. The Arduino asks us to place our finger in the sensor and press the switch.

Place any finger (except the Thumb) in the sensor clip and push the switch (button). Based on the data from the sensor, Arduino calculates the heart rate and displays the heartbeat in bpm.

While the sensor is collecting the data, sit down and relax and do not shake the wire as it might result in faulty values.

After the result is displayed on the LCD, if you want to perform another test, just push the rest button on the Arduino and start the procedure once again.

VI. MERITS AND DEMERITS

MERITS:

- Low power consumption
- More reliable
- More compatible
- Less cost

DEMERITS:

- The system may fail when there is no internet.

APPLICATIONS

- Very compatible it is very use full in medical camps.
- Useful in hospitals it reduces the heavy equipment.
- Very use full in taking care of disabled persons.

VII. CONCLUSION

We conclude that healthcare monitoring is done by using wireless sensor devices and report all the sensor data to the physician. During the healthcare monitoring if any patient health condition is critical, then send an emergency notification message to the physician by using GPRS technology. We are using heart beat sensor which is controlled by microcontroller. We have used GPRS technology for sending notification patients condition to the cloud server.

REFERENCES

[1] Vandana Milind Rohokale, Neeli Rashmi Prasad, Ramjee Prasad “A Cooperative Internet of Things (IoT) for Rural Healthcare Monitoring and Control” 2011 Center for TeleInFrastructure, Aalborg University, Denmark, P.P 978-1-4577-0787-2/11.

[2] Charalampos Doukas, Ilias Maglogiannis “Bringing IoT and Cloud Computing towards Pervasive Healthcare”

2012 Sixth International Conference on Innovative Mobile and Internet Services in Ubiquitous Computing, P.P 978-0-7695-4684-1/12.

- [3] Junaid Mohammed, Abhinav Thakral, Adrian Filip Ocneanu, Colin Jones, Chung-Horng Lung, Andy Adler “Internet of Things: Remote Patient Monitoring Using Web Services and Cloud Computing” 2014 IEEE International Conference on Internet of Things (iThings 2014), Green Computing and Communications (GreenCom2014), and Cyber-Physical-Social Computing (CPSCoM 2014), P.P 978-1-4799-5967-9/14.
- [4] Tae-Yoon Kim, Sungkwan Youm, Jai-Jin Jung, Eui-Jik Kim “Multi-hop WBAN Construction for Healthcare IoT” 2015 International Conference on Platform Technology and Service, P.P 978-1-4799-1888-1/15.