

Implementation of Ferro-Guard For Patient Safety

Nitin Jadhav¹, Ulhas Patil², Prabhakar Bhadange³

¹Dept of E&TC

²HOD ,Dept of E&TC

^{1,2} Anna University Regional Campus Coimbatore

³Manager, R&D Sivananda Electronics Pvt Ltd, Nashik, India

Abstract- Ferromagnetic detectors are the systems or devices, which are used to detect objects that become dangerous under the powerful magnetic fields of a Magnetic resonance system. Magnetic resonance (MR) scanners generate a powerful magnetic field and causes the ferromagnetic objects to become projectile. Which in turn causes huge damages to the equipment, patient and around. To give a few examples of such ferromagnetic objects are Oxygen cylinder, IV rods, scissors, and even hairpins. Attracted to the MR scanner bore with great force. The missile effect virtually leaves no time to react and causes the accident. In order to avoid such accident and overcome the above-mentioned issues we propose a Ferro-guard for patient safety to detect presence of ferromagnetic materials before entering in the MRI scanning Room/Area.

Keywords- Ferro-guard , Ferromagnetic detectors , Low cost, Logic control unit,Infrared(IR)

I. INTRODUCTION

A ferromagnetic detection system (FMDS) is available for use in the MRI environment. There are various configurations of the FMDS which exists it can come in a portable system, in a pillar, or as a handheld version. The devices are specially designed to detect ferromagnetic objects. In addition, discard other materials such as aluminum, copper, which come under non-ferromagnetic category.

As an example the FMDS will detect a steel gas cylinder and will alarm for its risk for taking inside the MR scanner zone, while will not generate the alarm for non-ferromagnetic material.Hence as the name suggest Ferro-guard , it selectively filters /generates alarms for ferromagnetic materials and keeps silent for non-ferromagnetic materials

The hazard of Missile effect which essentially means , the rate at which the MR magnet bore pull the ferromagnetic objects towards itself is so intense that it replicates a missile. Under such condition, the damages are enormous and by the time, the person handling is virtually unaware and has no time to react. The proposed system will drastically bring down the accidents by providing additional checks along with the

manual check or declarations happening before the MR scan of the patient.

II. SYSTEM SPECIFICATION

Following are the proposed system level specification:

- Electronic hardware should be able to operate for a typical 230 V AC 50 Hz mains or 12V battery system
- Maximum current consumption /12mA
- Easy to install and maintain

III. MODELLING AND SYSTEM DEVELOPMENT

The essential parts from system implementation point of view are as follows:

- Passive Sensor Coil
- Amplifier stages
- Filter stages
- I-V convertor
- Logic control unit
- Sensitivity selector
- IR- sensors
- Power supply
- Alarm indicator
- Buzzer driver

A. System Block Diagram

“Fig 1” shows the basic block diagram

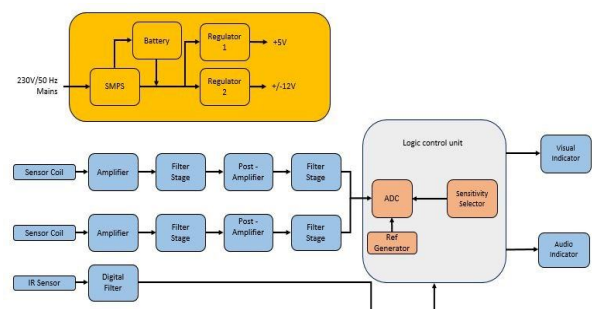

Fig. 1. System Level Block Diagram

B. IR Transmitter and Receiver

Transmitter comprises 12 TIL38 IRs arranged in two columns each consisting of six IRs also known as through beam sensors as shown in Figure 4.2. The reason for using IRs is that they give high or low output depending on the logic used whenever an obstacle comes in between transmitter and receiver. At the receiver end we propose to use 12 L14G1 IR receiver beam sensors. Receivers are aligned horizontally and vertically same as that of IR transmitters. There is synchronization among each transmitter and receiver. When there is an obstacle, the logic output of the IR receiver will change its state. With 12 IR pairs it is ensured that there will be no false alarm.

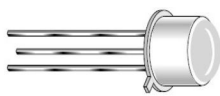

Fig. 2. LG14G1 Photo Transistor

C. Digital Filter

The output from the IR stage is feed to the digital filter. The digital filter is constructed using the IC4011 CMOS NAND gates and RC components . The pulsed output is feed to one network of RC filter and NAND gate and the original input to other network of the NAND gate. The circuit is shown in Fig 3.

This enable to avoid false triggering, essentially the comparator output is stretched by the RC time constant and checked with the original signal , if it's a spike (noise), its inverted ANDING will be Zero and there will be no ouput at A which is going to controller and this input will serve as the trigger to Alarm and Display units. Hence for signals having signal width less than (RC time constant) will be neglected. And only valid detections would be sensed and processed by the microcontroller.

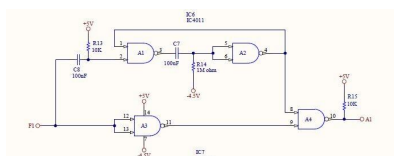

Fig. 3. Digital Filter

Courtesy SIVANANDA ELECTRONICS Reprinted By Permission

D. Current to Voltage Stage

Fig 4 shows the I to V converter The Coil two ends are connected to the Op-amp inverting and noninverting input. The op-amp is in inverting configuration.LA2 and LA2 along with CA1 CA2 form the filter circuit at the input of the Op-amp. D1 is used for protection against reverse voltage or short circuit. The Gain of the amplifier G1 is defined by values of RA3 and RA6. The output (6) of Opampis feed to the active filter circuit.

E. Filter Stage

The configuration used for the Filter design is a 3rd order

Sallen-key Low pass filter. Fig 5 shows Sallen-key Low Pass

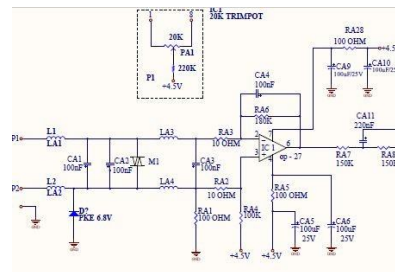

Fig. 4. I to V converter

Courtesy SIVANANDA ELECTRONICS Reprinted By Permission

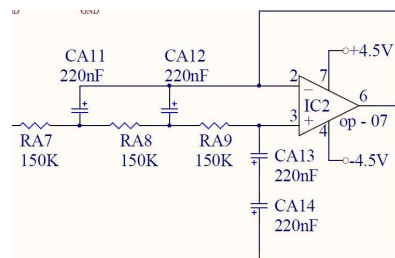

Fig. 5. 3rd order Sallen-key Low Pass Filter

Courtesy SIVANANDA ELECTRONICS Reprinted By Permission

Filter The values of filtering components are selected such that we get cut-off frequency at close to 10Hz. The op-amp is used in the unity gain configuration. The filtered signal is feed to the next stage . The next stage is the gain stage.

F. Gain Stage

As we very well know the gain stage is required to bring the signal in the dynamic range of the ADC of the

microcontroller so that the signal can be measured . The fig 6 shows the first gain stage .

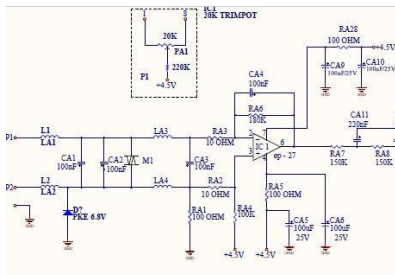

Fig. 6. First Gain Stage

Courtesy SIVANANDA ELECTRONICS Reprinted By Permission

- The Amplifier will follow the equation of :

$$V_{Out} = G \cdot I_{in} \quad \text{where } G = \frac{R_f}{R_i} \quad (1)$$

Where V_{Out} is the output voltage proportional to the product of G and I_{in}

Similarily fig 7 shows the second gain stage

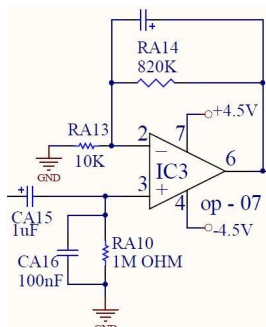

Fig. 7. Second Gain Stage

Courtesy SIVANANDA ELECTRONICS Reprinted By Permission

- The Amplifier will follow the equation of :

$$V_{Out} = G \cdot V_{in} \quad \text{where } G = 1 + \frac{R_f}{R_i} \quad (2)$$

- The capacitor at the non inverting input serves as a Zero DC input .
- G . Logic control Unit

The Logic control unit includes the Microcontroller and its periphery. Fig 8 shows the microcontroller (Logic control Unit).

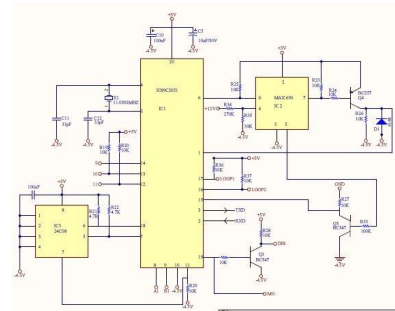

Fig. 8. Microcontroller Interface

Courtesy SIVANANDA ELECTRONICS Reprinted By Permission

- Pins 4,5 are connected to crystal oscillator of 11.0592Mhz • Pins 5 is connected to DVCC (Digital power) & Pin 10 to DGND (Digital ground)
- pin 18 and 2 are used to connect to external EEPROM for sensitivity setting storage. Every time the system is reset or at power on , it will read the sensitivity setting and configure the Mux/Demux lines accordingly.
- Pins 12,13,14 are select lines connected to Mux/Demux

IV. CONCLUSION

With the proposed architecture, we can detect the ferromagnetic material presence. The system usage in MR scanning rooms or hospitals will drastically bring the incidents occurrences to low. The system will act as a level two check along with the manual checks, which happens at mentioned locations. Use of sensitivity selections allows nullifying the floor noise, generated due to other magnetic materials and reduces the false alarm.

The system proposed is scalable, it means the by increasing the sensor coil changes the detection zone and distance can be increased. With present design, we propose to detect an object as small as hairpin from a distance of 10 meter. The system is robust and requires minimum efforts for installation. In addition, the overall cost of the system is competitive.

V. ACKNOWLEDGMENT

I owe my deepest gratitude and indebtedness to my highly respected and esteemed guide Prof. U.V.Patil, Department of Electronics & Telecommunication Engineering, Sir Visvesvaraya Memorial Engineering College, Nasik (Maharashtra) and Mr. Prabhakar Bhadange , Manager R&D Sivananda Electronics Pvt Ltd for being a

continuous source of inspiration, guidance, sincere criticism and regular feedback on my advancement each week I was able to learn and improve upon my working strategy and thus, enhance my approach during this piece of work. It was because of their stimulating suggestions and comments that I could identify the right topic and always keep in the right track.

REFERENCES

- [1] Matthew John, “apparatus for detecting ferromagnetic objects and a protected doorway assembly,” WO 2012/022971 (23.02.2012 Gazette 2012/08),Jan 2011.
- [2] AT89C51 Datasheet, Atmel Corporation, America.
- [3] Online.: “<http://www.sivanandaelectronics.com>”.
- [4] S.Tumanskii. induction coil sensors a review”. IEEE, pages PP 114, October 2000.
- [5] OP07x Precision Operational Amplifiers Datasheet, Texas Instruments, America.
- [6] 24C08B Datasheet, Microchip Technology Inc