

Industrial Robot Based Painting Application

Prof. Prashant G. Salunkhe¹, Ms. Shruti R.Wagh²

Department of Electronics and Telecommunication Engineering

² Sandip Foundation (SITRC) Nashik, India

¹ Assistant Professor, Sandip Foundation (SITRC) Nashik, India.

Abstract- Robotic for painting is one of the most forward application for robot. Robotic color painting is the process in which spray painting is done by robots or robotic arm to reduce human effort and to increase correctness of system. This paper describes the robotic arm system which is implemented in order to obtain high accuracy, repeatability automatically using SCADA system. Cost effectiveness, human safety factor, quick results makes this system a reliable one for painting applications

Keywords- SCADA, Robot Controller, Robotic Arm.

I. INTRODUCTION

Technology is growing at a point that no one has been able to measure or evaluate precisely. We have witnessed the invention of robots ,machines, electricity etc. Industrial and personal purposes. They perform different tasks based on how they have been programmed or taught manually. The project places emphasis on industrial painting using painting robot. The robot is a 6 axis industrial robot, designed specifically for any industry that uses flexible robot based automation. The robot has an open structure that is adapted for responsive use and can communicate extensively with external systems. It can be used for project based applications , researches and for industrial purposes. Robot includes welding cutting, pick and place, assembling ,painting and inspecting.



Figure 1. Robotic Arm [7]

Figure 1 shows the body diagram for mechanical design of the robotic arm. A robotic arm with only four degrees of freedom is designed because it is adequate for most of the necessary movement. At the same time, it is competitive by its complexity and cost-saving as number of actuators in the robotic arm increase with degrees of freedom. In a robotic system, the number of degrees of freedom is determined by the number of independent joint variable.

II. LITERATURE SURVEY

The discussion on how a robotic spraying automatic would boost up a production rate and how simulation can help overcome the paint constrains Robotics technology embraces multiple disciplines such as structural mechanics, material physics, power electronics, computer science, software engineering, etc. The continuous progress and discrete breakthroughs in respective discipline have altogether contributed to a remarkable improvement in performance of industrial robots.

This paper Dr. Bindu A Thomas, discuss about the Industry Based Automatic Robotic Arm [1]. The use of industrial robots is increasing in areas such as food, consumer goods, wood, plastics and electronics, but is still mostly concentrated in the automotive industry. The aim of this project has been to develop a concept of a lightweight robot using lightweight materials such as aluminum and carbon fiber together with a newly developed stepper motor prototype. The wrist also needs to be constructed for cabling to run through on the inside. It is expensive to change cables and therefore the designing to reduce the friction on cable, is crucial to increase time between maintenance. A concept generation was performed based on the function analysis, the specifications of requirements that had been established. From the concept generation, twenty-four sustainable concepts divided into four groups (rep-representing an individual part of the whole concept) were evaluated.

This paper P. Madhuraghava1, D. Fakruddin Basha2, V.Subhash Reddy3, N. sunil discuss about the Modelling and Structural, Analysis of a 6-DOF Robot Spray Coating Manipulator[2] In automobile most products manufacture from metallic materials require some form of painted finish before delivery to the customer, the technology for applying

these finishes varies in complexity from simple manual methods to highly sophisticated automatic techniques. When accomplished manually, the result in many health hazards to the human operator these include fumes and mist in the air, noise from the nozzle, fire hazards and potential cancer hazards. The feature of many robot spray coating applications is that the manipulator must be designed and analysis to process a variety of part styles, each with its unique configuration.

This paper Rahul Gautam is discuss about Review on Development of Industrial Robotic Arm [3] A robotic arm is a robotic manipulator, usually programmable, with similar functions to a human arm. Humans pick things up without thinking about the steps involved. In order for a robot or a robotic arm to pick up or move something, someone has to tell it to perform several actions in a particular order from moving the arm, to rotating the wrist to opening and closing the hand or fingers. So, we can control each joint. This paper presents a three joint automatic robotic arm which can be used in industries to do repetitive task such as moving the things from conveyor to another place, a sensor will be used to detect the obstacles if present while carrying out the task. If there is any obstacle while moving the object, the arm will wait for a predefined time for the clearance of the object. If the obstacle is cleared, the arm will continue its work. If the obstacle is still present, a buzzer will be turned on so that personnel from the industry can attend the problem and clear the obstacle.

This paper S.C. Jacobsen M. Olivier are discuss about the Applications in Artificial Intelligence, Teleoperation and Entertainment[4]. In addition to the robots and their sub-systems, extensive work has been devoted to command systems that drive the robots. Command systems have been: playback supervisors, teleoperation masters, and various higher level approaches based on work from the AI community. Playback interfaces have included motion capture mechanisms that provide movement stream information to storage systems configured for later, repeated and coordinated, operation of many robots and associated mechanisms. Playback command systems use human commands, from an earlier time, to command motions that are played out, over and over, mindlessly. Tele operation masters, that operate in real-time with the robot, have ranged from simple motion capture devices, to more complex force reflective exoskeletal masters. Teleoperation interfaces have been composed of complex kinematic structures designed to perform motions compatible with operator movements and are attached via appropriate soft tissue interfaces. The masters emit lower level commands (joint angles) in real-time using the natural intelligence and sensory systems of the operator.

This paper Ijeoma W. Muzan1, \Implementation of Industrial Robot for Painting Applications"[5]. Robot for painting is one of the earliest applications for industrial robot, however, the precision and finishing for the painting is an important issue for any painting job. Accordingly, the aim of this project is utilize an industrial robot (ABB robot model IRB1410) for painting applications. The robot was programmed to paint alphabets using its Flex pendant. The Flex Pendant was used to manually teach the robot how to follow the paths for specific targets of letters. The robot End Effector (painting tool) was chosen and mounted on the robot to perform an effective painting task. It was programmed based on its functionality. Finally suitable painting environment was designing. Two software packages were used in this project. The Computer Aided Design (CAD) of the system work-objects and end effector was programmed based on Solid works software. Robot studio Software used to program the paths and target of the alphabets to be painted by the IRB1400 Robot which generate a RAPID GUI code used for robot interfacing. The final results demonstrate that implementation such system helps to boost the quality of painting, reduce paint consumption and improve safety.

III. PROPOSED SYSTEM

A. System Architecture

In this paper we have proposed a system for industrial robot based painting application and its block diagram is as shown in fig.1 The prime elements of the proposed system are the robot controller and motor. The robot controller is connected to all devices such as servo motor, current driver IC, object sensor, buzzer, PC interface and a SMPS. The robot controller which is KPM-2 is a high integrated functional computer system on chip. It contains an integrated memory and programmable input or output peripherals. It is used to control motor activation and deactivation operation and also reads sensor signal. Motor driver IC is used to provide the required amperage to the motor using the low current signal from the robot controller. A motor controller is a device or group of devices that serves to govern in some predetermined manner the performance of an electric motor. A motor controller might include a manual or automatic means for starting and stopping the motor, selecting forward or reverse rotation, selecting and regulating the speed, regulating or limiting the torque and protecting against overload and faults. An electric motor is an electromechanical device that converts electrical energy into mechanical energy. Electric motors can be powered by direct current sources, such as from batteries. Robot controllers command these motors through the driver circuit to take the necessary action. Here we are using ultrasonic object sensor(HC-SR04) for sensing the

object. Power the sensor using a regulated +5V through the Vcc and ground pins of the sensor. The current consumed by the sensor is less than 15mA and hence they can be connected to I/O pins of the robot controller. To start the measurement, the trigger pin has to be made high for 10uS and then turned off. This action will trigger an ultrasonic wave at frequency of 40Hz from the transmitter and the receiver will wait for the wave to return. Once the wave is returned after it getting reflected by any object the echo pin goes high for a particular amount of time which will be equal to the time taken for the wave to return back to the sensor. The amount of time during which the echo pin stays high is measured by the MCU/MPU as it gives the information about the distance is measured. A buzzer or beeper is an audio signalling device, which may be mechanical, electromechanical or piezoelectric [piezo for short]. Typical uses of buzzers and beepers include alarm devices ,timers, and confirmation of user input such as mouse click or keystroke. Here buzzer is used when spray painting is done.

allowing the system to indicate the effects of the users manipulation.

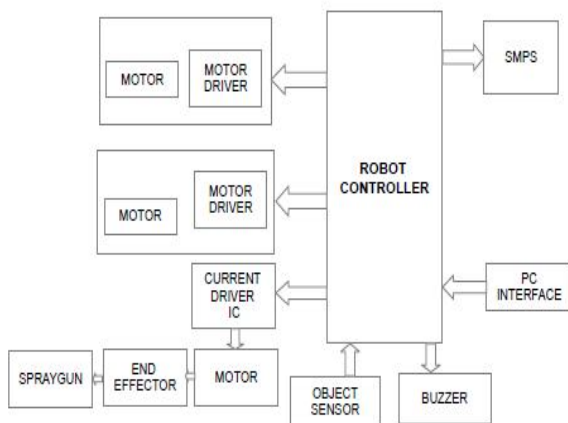

Figure 2. Block Diagram Of Proposed System

B. PC Interface

In the industrial design field of human-machine interaction, the user interface is where interaction between humans and machines occurs. The goal of interaction between a human and a machine at the user interface is effective operation and control of the machine, and feedback from the machine which aids the operator in making operational decisions. A user interface is the system by which people (users) interact with a machine. The user interface includes hardware (physical) and software (logical) components. User interfaces exist for various systems, and provide a means of Input, allowing the users to manipulate a system. Output,

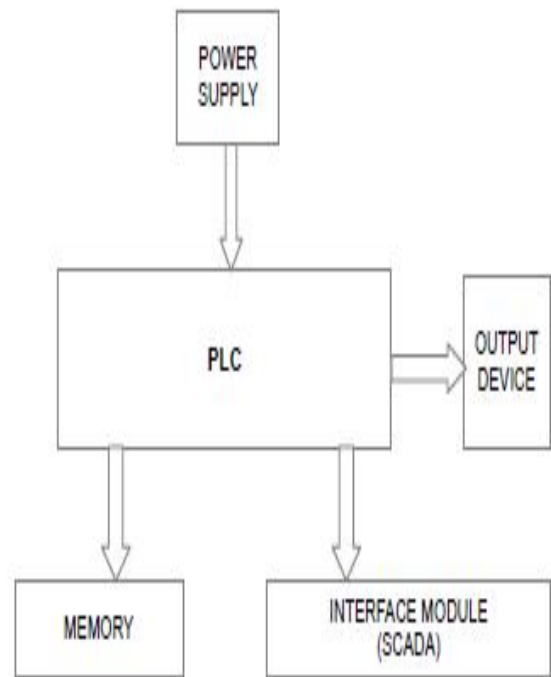

Figure 3. Block diagram of PC interface

C. Workflow

The required flow of the entire proposed system is as shown in Figure 4. Once the system is powered up, first initialize the computer then press the start button which is present on the computer screen. After sending the signal robot will wait for the signal. After receiving a signal robot will start the moving then it gives signal to the conveyer belt then conveyer belt will start functioning. Robotic arm will be move in downward direction for car painting from downward to upward direction. Conveyer belt is moving till sensor sense the object perfectly. After that when sensor sense the object moving arm will make paint on object wait for a another signal. In the another side when paint is make the information about the painting will be automatically updated on the computer screen. If signal is not received then robot will stop the operation and if signal is received then it perform the next part of car.

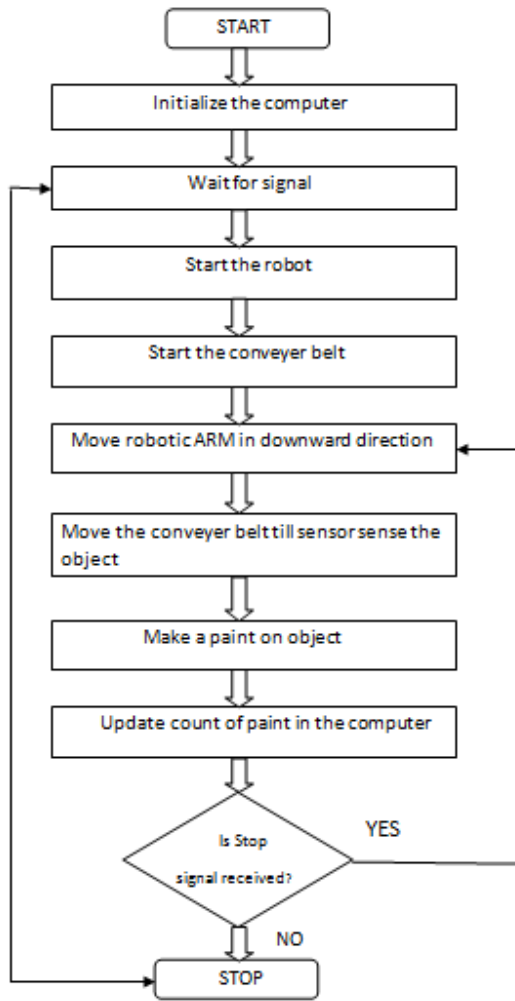

Figure 4. Workflow of proposed system

The basic robotic system broadly defines the mechanics, control, and sensor design of Robots. Mechanics includes the design and structure of manipulators, arms, end-effectors, actuators, power, and energy storage. It also consists of the kinematics, dynamics of Robots, and simulation of Robot Systems. Control includes both theory and implementation (hard-ware and software) while Sensors include design of sensor systems and algorithms for sensory data acquisition and analysis. The study of Robotic System and its components were applied in the project. The project design and simulation where based on all the components. The other component that played a very vital role in the project is the design of the robot Work Object, air compressor and the paint being used in the spraying process.

IV. TYPES OF PAINTING SYSTEM

Every metallic material will be painted at the final stage of production in order to protect it from corrosion. In an

automobile industry, the finished metals are painted with different colors for attracting the customers. In olden days, this painting process was done by two methods such as spray coating and immersion flow coating methods. Figure 5 shows various types of painting system.



Figure 5. Types of painting system

1. Spray Coating method

In the spray coating method, a spray gun is used to coat the paints on a metal. It is done manually by the well skilled human labors. This process can be performed by three different ways, namely:

1. Airless spray method.
2. Air spray method
3. Electrostatic spray method

2. Immersion and Flow Coating methods

The operation of immersion and flow coating methods are almost similar to each other. Both these methods are very simple techniques in the painting process. In the immersion method, a metal is dropped into a paint tank and taken out. The surplus of paints is sent back to the tank. The metals that are to be painted are placed on top of the paint tank in the flow coating method. In this process, the paint is made to flow on the metal for painting

V. CONCLUSION

The social value of robotics is that these wonderfully subservient machines will permit humans more time to do

work that is more challenging, creative, conceptual, constructive and co-operative than at present. There is every reason to believe that the automation of work through robotics will lead to substantial increases in productivity, and that these productivity increases year by year will permit humans to engage in activities that are cultural and recreational

REFERENCES

- [1] Rahul Gautam, Ankush Gedam, Ashish Zade, Ajay Mahawadiwar, \ Review on Development of Industrial Robotic Arm ", Patil College Of Engineering, Nagpur, Maharashtra, India Patil College Of Engineering, Volume 4, Issue 3, Mar -2017.
- [2] Dr. Bindu A Thomas, Stafford Michahial, Shreeraksha.P, Vijayashri B Nagvi, \ Industry Based Automatic Robotic Arm", institute of VidyaVikas Engineering and Technology, Volume 2, Issue 11, May 2013.
- [3] Ijeoma W. Muzan, Tarig Faisal, \Implementation of Industrial Robot for Painting Applications " Mechanical Engineering, Selangor,2012.
- [4] P. Madhuraghava, D. Fakruddin Basha, V.Subhash Reddy,\ Modelling and Structural, Analysis of a 6-DOF Robot Spray Coating Manipulator" Mechanical Engg Dept., Nandyal, Volume 7, Issue 1, 2018.
- [5] www.allaboutrobotics.com.
- [6] <http://robotics.eecs.berkeley.edu/ronf/milli-robot.html>
- [7] <https://www.robots.com/images/robots/KUKA/Medium-Payload/KUKA KR 60 cutout.png>
- [8] <https://www.fanucamerica.com/industrial-solutions/manufacturing-applications/painting-robots>
- [9] https://www.kuka.com/en-in/products/robotics-systems/ready2_solution/kuka-ready2_spray
- [10] <https://www.robots.com/applications/painting-automation>