

Visitor Monitoring System Using Raspberry Pi

Review Paper

Ms. Vaishnavee V. Joshi¹, Prof. Omkar Vaidya²

^{1,2}Dept of Electronics and Telecommunication

^{1,2}Sandip Foundation (SITRC), Nashik, India

Abstract- *This Visitor Monitoring System (VMS) provides an easy method for the front desk officer to search the ongoing visitor of the day and keep a track of their visit.*

Achieving a secure environment is very important for all organizations as it is a matter of security. Our application would help such organizations to safeguard their organization from unwanted visitors. Thus, by use of minimum resources, our application would help an organization to keep a track of visitors and maintain a record of the same for future substantiation.

In our proposed system camera is interfaced with Raspberry Pi to capture the image of every visitor which has entered through the Gate or door. For Face detection Haar cascade algorithm is used and for Face Recognition Numpy and Pillow Python algorithm is used. Thus, creating the Database of Visitor visiting the organization. The Visitor gets entry after validating his identity by face recognition technique or by sending OTP to his registered mobile Number. This can be very useful for restricting the unauthorized person to enter into the campus.

Keywords- Image processing, Face Recognition, Database generation, Raspberry pi.

I. INTRODUCTION

Nowadays new technology is creating a new way for security and automation. As people are busy in their day to day busy lifestyle so assuring safety of their things is a prioritized aspect now. The cases of Robbery are increasing day by day not only in home but also in industrial areas or in any organization. So, to be secured it is mandatory to restrict the stranger from entering into organization. To fulfil this we need the Visitor Monitoring System is useful.

Visitor Monitoring System (VMS) provides an easy method for the front desk officer to search the ongoing visitor of the day. Thus maintaining record of all incoming and outgoing visitor/employee is easy by using VMS. Currently, most organization is using the named method in keeping track all the incoming and outgoing visitor records in each of the

department. Problem raised when at certain point of time the number of visitors visiting the department increasing and unable to manage and messed up.

Furthermore, the log register has been used to track all the visitor records and it is not enough. Log register is not an efficient way to keep records of several years, and in order to produce reports, retrieve or inquiry previous records especially 2-3 years back is very hard to get and taking a lot of time to retrieve the records and reports.

VMS also helps user access information enquiry faster. By using VMS the difficult manually searching procedure will become easy. Imagine there was hundreds of visitors coming in and out. However, with the new system, user only need to search via card number and as a result, the system will display related output that been entered by the user earlier. Problem such as waiting for a long-time queue will be no more a problem and will give an impression of well-organized system.

Achieving a secure environment is very important for all organizations as it is a matter of security. Thus, by use of minimum resources, our application would help an organization to keep a track of visitors and maintain a record of the same for future substantiation.

Here in the proposed system we are going to implement the VMS using raspberry pi with image processing. In this Raspberry pi is the main controller. In this automated system for security purpose the face detection system is used, the visitor identity is detected and compared with the stored database. So that the unknown person cannot enter into the industry premises without a valid identity. If the person is valid then the mail to the respective manager to whom the visitor has come to meet is delivered.

After the meeting the manager shoot the mail of meeting over. The Visitor entry time, exit time, to whom he came for meeting his name, etc. data is recorded and stored in the database.

II. LITERATURE SURVEY

Harish Rapartiwar, Pushpanjali Shivratri, Omkar Sonakul, Prof. Ashwini Bhugul [1] developed system solves the problem of appointments and it electively capturing all-relevant information about the visitors and that information is recorded in centralized database server, which provides data management.

Mr. Mogare Sumit R, Sanagare Prathamesh S, Ms. Anjarlekar Shraddha S, Mr. Kharat Ratnadipak N, Mr. Shikalgar Isaq A. [2] designed system about Biometric Identification using Raspberry Pi. In this project, security provided that means the persons from outside is not entering a home without permission of the owner. This project alerts the house owner that who is going to enter in his home. If any stranger person wants to come, then that person is seen by owner's first and then the owner can decide meet to that person or not. This can be done using Raspberry pi and Image processing technology. Biometric identification is the main feature of this project. Person's face is recognized by using web camera and that details are sent to the owner mobile android app by using Raspberry pi through Wi-Fi module. The gate opens automatically by pressing the button in the android app if the owner wants to take inside that person. Gate will be automatically close after some time. This system is useful for home as well as also to society.

K.S. Shilpashree, Lokesha.H, Hadimani Shivkumar [3] designed the implementation of image processing operations on Raspberry Pi. The Raspberry Pi is a low cost a single board computer used to reduce complexity of real time applications. This platform is mainly based on python. To interface the Raspberry pi Camera, Camera slot Interface (CSI) to interface the Raspberry pi camera. To identify the particular region of image the Dark and Low contrast images captured by using the Raspberry Pi camera This concept is used in the real time application of MAV (micro air vehicle).

Behzad Shoarian Satari, Nor Azlina Abd Rahman, Zety Marla Zainal Abidin [4] developed system that able to manage and monitor the visitors of an organization using face Recognition as an authentication method. After the authentication and verification process, valid visitor ID get printed that contains face image of the visitor, date and time of visiting and the name of the person to be visited. Face recognition visitors management system (FRVMS) is proposed to enhance the security of an organization from outsiders that entering the building illegally for certain purposes such as spying or stealing the organization assets.

Amritha Nag, Nikhilendra J N, Mrutyunjay Kalmath [5] Implemented system for improvement of the door security of sensitive locations by using face detection and recognition. The proposed system mainly consists of subsystems namely image capture, face detection and recognition, email notification and automatic door access management. Face Recognition supported openCV is brought up because it uses Eigen faces and reduces the scale of face images without losing vital features, facial images for many persons can be stored in the database. The door lock can also be accessed remotely from any part of the world by using Telegram android application. The captured image from picamera will be sent to the authorized person through email for safety purposes.

Nashwan Adnan Othman, Ilhan Aydin [6] developed a real time recognition system is proposed that will equip for handling images very quickly. This paper tells how to identify faces at various places such as home, office etc. Movements in dedicated area are detected by PIR. Afterwards, the Raspberry Pi will capture the images and the face is recognized. Finally, the images and notifications will be sent to a smart phone based IoT by using Telegram application. The Proposed systems are real-time, fast and has low computational cost.

Mangayarkarasi Nehru, Dr. Padmavati [7] studied illumination face detection using Viola Jones Algorithm. Viola Jones Cascade Object Detector which uses various filters and the features to detect the various parts of the face. The main moto is to make the computers detect the faces besides the non-facial structures present in an image with the detected part selected in it.

Norizan Anwar, Mohamad Noorman Masrek, Yanty Rahayu Rambli [8] implemented Visitor Management System in order to monitor visitor movement inside organization. Person at one section can monitor application through LAN (Intranet) with standard web browser. It adapt the Use of Technology model (UTAUT) to determine the user acceptance of visitor application system.

M. Vadivel, M. Poongodhai, R. Madhumitha, V. Nivetha, J. Kamila Banu [9] implemented the face recognition to a level in which the system can replace the use of passwords and RF I-Cards for access to high security systems and buildings. By using these Raspberry the system becomes cost effective and easy to use, with high performance. This paper details the design and development of IOT based security surveillance system in buildings using Raspberry Pi single board with Wi-Fi network connectivity. Upon detecting the face, the controller enables the camera for capturing the

event, alerts the user by placing the live video of that event on webpage that is displayed in android mobile.

Md. Nasimuzzaman Chowdhury, Md. Shiblee Nooman, Srijon Sarker [10] developed system to connect any door with the internet to control door access from anywhere in the world. In a case absence of one at his home and a visitor is at the door steps then the authorized person will be notified about the visitor via twitter and the person can see the visitor through web via camera and the system will take a picture of the visitor and keep a record by sending an attachment through E-mail or tweet. If the authorized person wants to give a message it can be sent easily through the internet and message appears in a screen on the door. The door lock can be controlled by the internet. By using this system an evidence of the visitor can be recorded for emergencies.

Omar Abdul Rhman Salim, Rashidah Funke Olanrewaju, Wasiu Adebayo Balogun [11] developed a comprehensive embedded class attendance system using facial recognition with controlling the door access. The system is based on Raspberry Pi that runs Raspbian (Linux) Operating System installed on micro SD card. The Raspberry Pi Camera, as well as a 5-inch screen, are connected to the Raspberry Pi. By facing the camera, the camera will capture the image then pass it to the Raspberry Pi which is programmed to handle the face recognition by implementing the Local Binary Patterns algorithm LBPs. If the student's input image matches with the trained dataset image the prototype door will open using Servo Motor, then the attendance results will be stored in the MySQL database. The database is connected to Attendance Management System (AMS) web server, which makes the attendance results reachable to any online connected web browser. The system has 95% accuracy.

Kirti Dang, Shanu Sharma [12] analysed various face detection algorithm Viola-Jones, SMQT features & SNOW Classifier, Neural Network-Based Face Detection and Support Vector Machine-Based face detection. All the comparison of face detection method are dependent on DetEval Software by using their calculated precision and recall value of the bounding boxes around the faces to give accurate results.

III. PROPOSED ARCHITECTURE

In this paper we have proposed the Visitor Monitoring system using Raspberry Pi based on image processing techniques. The use of Raspberry Pi makes the system implementation easy. The Pi camera can also be used for high pixel resolution use of another web camera is beneficial.

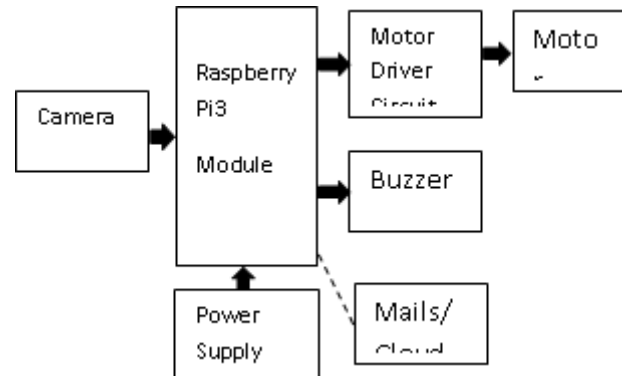

Figure 1 Block Diagram

WORKING:

The camera is interface to the raspberry pi module. The pi module is power up by a 5V. This power supply is nothing but the 5V Adapter which is readily available in market power supply. The buzzer and stepper motor are interface to the pi module. When the visitor arrives, he will press the button at the door, as the button gets press the pi instructs the camera to capture the image of the visitor.

This captured image is compared with the images stored in database. If it matches then the motor is driven and the gate gets open or else it will not get open. As the door gets open and entry of the visitor is done, the mail to the respective employee to whom visitor has come to meet is delivered. Similarly, when the meeting is over the employee shoot a mail to security guard. The recorded data is accessible any time anywhere as the database is shared on clouds.

SYSTEM COMPONENTS

1. RASPBERRY PI3 MODULE :



Figure 1 Raspberry Pi Module

Specifications for Raspberry Pi-3 model B+ are 64-bit 1.4 GHz having quad core processor, with 1GB of RAM, having dual band 802.11b/g/n/ac wireless LAN, Bluetooth 4.2, and significantly faster 300Mbit/s Ethernet.

2. STEPPER MOTOR

Stepper Motor are low cost,high reliable and their performance rate is high at low digital frequency.

INSTALLATION OF OS IN RASPBERRY PI

Tools needed for installation: -

- Raspberry pi board for sure.
- SD card and its reader.
- Monitor and HDMI to Vega if the monitor doesn't have HDMI port.
- 5V converter

Steps of installation:

- Download the latest version of Raspbian on the Raspberry Pi from foundation's website.
- Unzip the file.
- Write the disc image to your microSD card(by using Etcher).
- Put the microSD card in your Pi and boot up.
- Edit Password.

Platform & Language Used:

- Platform used for algorithm implementation: OPEN CV
- Language used for implementation: PYTHON

Why OPEN CV?

1. **Faster & Free:** With BSD License for Open CV, you get all the features for free. Also, optimized code runs faster than MATLAB.
2. **Richer & Bigger community:** With regular improvements and over 40000 developers, its one huge family.
3. **Portability:** Due to its source-code in C/C++, any machine capable of running C/C++ (Linux) can have open CV running as well.

IV. WORKFLOW DESIGN

The required flow of the proposed system is as shown in Figure 3.

Case A: When Visitor record already present in database

- When the Visitor arrive on the gate, he will press the button on the door.
- After Pressing the button, the raspberry pi instructs the camera to capture the visitor face and check whether it is matching with the already saved database.
- If matches then gate will be open.
- As soon as acknowledgment from the concern person is receive then that person is leaved for meeting inside the industry.
- When the meeting is over the manager shoot the mail that meeting is over and person has left the meeting zone.
- Some approximate time of 10 to 15 minute is given after the reception of the mail that the visitor must reach at the gate but if not, then the notification must be provided on gate security guard as well to the manager that something is wrong.
- During exit again the visitor face image is captured and if matches the gate is open for visitor
- Hence Name, Photo, entry timing, exit timing, concern meeting person name will all get recorded and store in database.

Case B: When Visitor record does not exist in database

- When the Visitor arrive on the gate, he will press the button on the door
- After pressing the button the raspberry pi instructs the camera to capture the visitor face and check whether it is matching.
- When it doesn't match with the database buzzer will ring (instructing that some stranger).

Case B1: Now the visitor name and phone number details are present in appointment list

- The OTP will be generated and send to the respective visitor phone.
- When the OTP gets match the door will get open The mail will get shoot to the respective person to whom the visitor has meeting is schedule.
- As soon as acknowledgment from the concern person is receive then that person is leaved for meeting inside the industry.
- When the meeting is over the manager shoot the mail that meeting is over and person has left the meeting zone.
- Some approximate time of 10 to 15 minute is given after the reception of the mail that the visitor must reach at the gate but if not, then the notification must

beprovided on gate security guard as well to the manager that something is wrong.

- During exit again the OTP is generated the gate is open for visitor
- Hence Name, Photo, entry timing, exit timing, concern meeting person name will all get recorded and store in database.

Case B2: If Visitor name is not present in appointment list also

The security guard has to contact the authorized person if he gave the permission then the databasecreation process has to be completed and visitor can get entry into the industry.

V. ALGORITHM

1. Face Detection Algorithm

The Viola-Jones algorithm, the real-time face detection system. This algorithm works on three principles: the integral image for featurecomputation, Adaboost for feature selection and an attentional cascade for efficient computational resource allocation.

In this Algorithm Object Detection using Haar feature-based cascade classifiers is done. Lot of positive (images with face) and negative (images without face) images train the cascade classifier which is a machine learning based approach.

Then the features of the image must get extracted. For this as shown in below image (in Figure 4), Haar features are used. These features are just like our convolutional kernel. After subtracting sum of pixels under white rectangle from sum of pixels under black rectangle each feature value is a single value.

Now to calculate plenty of features, all possible sizes and locations of each kernel are used. (Just imagine how much computation it needs? Even a 24x24 window results over 160000 features).

By finding sum of pixel under white and black rectangle we can calculate for each feature. Hence Integral images are used to do summation of each pixels, whatever the size of pixel maybe.

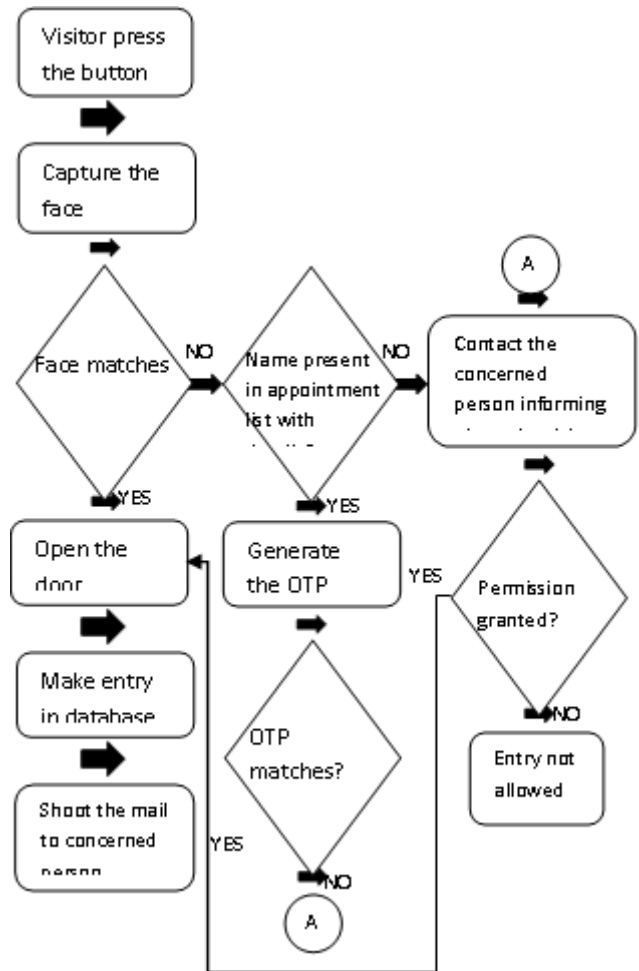

Figure 3 Flow of the System

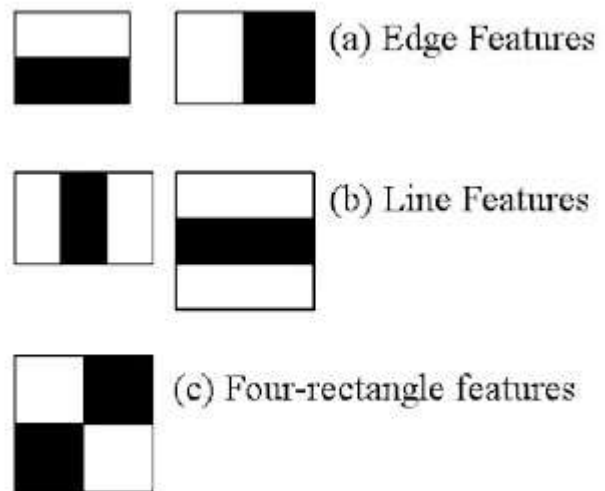

Figure 2 Rectangular Haar like feature

Among many of the calculated features only few are relevant. For example, consider the Figure 5. Good features are shown in top two rows. The selected first feature focusses that eyes region is darker than cheeks and nose. But second

feature focuses that eyes are darker than bridge of nose. Both the feature windows are irrelevant if applied in facial region other than eyes.

Hence best features from around 160,000+ are selected using **Adaboost**.

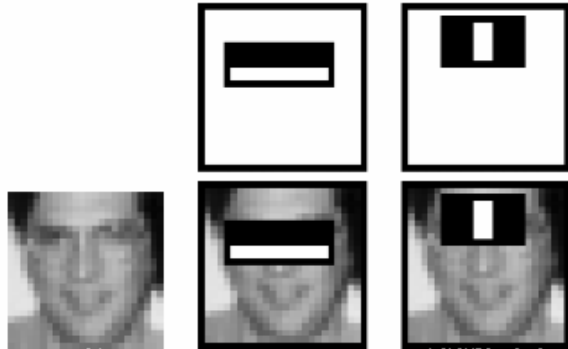

Figure 3 Haar like feature over face

On all training images each and every feature are applied. Hence for each feature best threshold values are calculated which will be used to classify the faces to Positive and negative. But there will be possibility for errors or misclassifications. Features with minimum error rate are selected to classify face and non-face images. Initially all images are weighted equally. After every classification, misclassified images weights are increased. Hence again new error rates with weights are calculated. The process is repeated until required accuracy or required features are found. But the final classification is a weak classification. So final classifier obtained is weighted sum of these weak classifiers. They are called weak because they have to take help from other classifiers to classify the images and hence afterwards become strong classifier. By above method mentioned there is reduction in selection of features from 160,000+ features to say around 6000 features. But still processing on these 6000 features is inefficient and time consuming.

So for this cascade of classifier concept is designed. As an alternative to apply all the 6000 features on window, the features are grouped into different stages of classifiers and each group is applied one by one. First few groups contain less number of features. If failure occurs in first attempt, then we discard that whole group of features and move towards second stage. This process is continued till the last stage. The face region is detected if window passes all stages.

2. Face Recognition Technique:

For Face Recognition Pillow library is used in Python. Pillow is a python Imaging Library (PIL) which adds

support for opening, to manipulating, and to save images. Write support is intentional restricted to the most commonly used interchange and presentation formats.

VI. CONCLUSION

The Overview of the Visitor Monitor system is described in this paper. The Visitor Monitoring System Workflow Module is described along with its hardware requirement. Thus the Visitor Monitoring System can reduce the organization threat from the stranger and criminal such as robbers.

REFERENCES

- [1] Harish Rapartiwar, Pushpanjali Shivratri, Omkar Sonakul, Prof. Ashwini Bhugul "Visitor Gate Pass Management System" International Journal Of computer science and mobile computing. 2017
- [2] Mr. Mogare Sumit R., Sanagare Prathamesh S., Ms. Anjarlekar Shraddha S., Mr. Kharat Ratnadipak N., Mr. Shikalgar Isaq A. "Automatic Gate Security System by using Raspberry Pi with Image Processing" International Journal for Research in Applied Science & Engineering Technology (IJRASET) April 2017
- [3] K.S. Shilpashree1, Lokesh H2, Hadimani Shivkumar3, "Implementation of Image Processing on Raspberry Pi" International Journal of Advanced Research in Computer and Communication Engineering May 201
- [4] Behzad Shoarian Satari, Nor Azlina Abd Rahman, Zety Marla Zainal Abidin "Face Recognition for Security Efficiency in Managing and Monitoring Visitors of an Organization" International Symposium on Biometrics and Security Technologies (ISBAST) 2014.
- [5] Amritha Nag, Nikhilendra J N, Mrutunjay Kalmath "Iot Based Door Access Control Using Face Recognition" 3rd International Conference for Convergence in Technology (I2CT) 2018.
- [6] Nashwan Adnan OTHMAN Ilhan AYDIN "A Face Recognition Method in the Internet of Things for Security Applications in Smart Homes and Cities" 6th International Istanbul Smart Grids and Cities Congress and Fair (ICSG) 2018.
- [7] Mangayarkarasi Nehru, Dr. Padmavati "Illumination Invariant Face Detection Using Viola Jones Algorithm" International Conference of Advanced Computing and Communication System.
- [8] Norizan Anwar, Mohamad Noorman Masrek, Yanty Rahayu Rambli "Visitor Management System by Applying the Model of UTAUT" IEEE Symposium on Business, Engineering and Industrial Applications. 2012

- [9] M.Vadivel1, M.Poongodhai, R.Madhumitha, V.Nivetha, J.KamilaBanu,IOT BASED HOME VISITOR MONITORING SYSTEM USING RASPBERRY PI. March 2018
- [10] Md. Nasimuzzaman Chowdhury, Md. Shiblee Nooman, Srijon Sarker “Access Control ofDoor and Home Security by Raspberry pi through Internet”Research Gate. November 2013
- [11] Omar Abdul Rhman, Salim Rashidah Funke, Olanrewaju Wasiu Adebayo Balogun“Class Attendance Management System Using FaceRecognition.7th International Conference on Computer and Communication Engineering (ICCCE) 2018.
- [12] Kirti Dang Shanu Sharma“Review and Comparison of Face Detection Algorithms” IEEE 2018