

Industrial Robot Based Automobile Drilling Application

Prof. Dr. Gayatri M. Phade¹, Miss. Aakanksha Anil Loharkar²

^{1,2}Dept of Electronics and Telecommunication

^{1,2}Sandip Foundation (SITRC) Nashik, India

Abstract- Industry requires drilling operation for different application like car manufacturing, electronics industry, forging and steel are some of them. In industries many a times people go for manual drilling, which increases human risks. If a worker drills the metal sheet by using his hand then there is a high risk of cutting and physical damage to the body, also the hazardous particles that are ejected during drilling may harm his health and body. If an individual is operating without industrial safety guidelines and utilities risk of particles entering in sensing open body parts like the eyes, nose and ears increases.

This paper summarizes the implementation of an robotic system which will automatically drill the sample with very high accuracy and precision. This will reduce the time, avoid human errors and enhance the quality with zero human risk. This robotic arm system is implemented in order to obtain high accuracy, repeatability automatically using the SCADA system. Hence our project gives a big and good impact for the manufacturing industries. Cost effectiveness, human safety factor, quick results makes this system a reliable one for drilling applications.

Keywords- SCADA, Robotic arm.

I. INTRODUCTION

This project tries to solve the human errors and overcome the human limitations in drilling process for industrial application. During manual usage laziness, inaccuracy, time and cost utilization hampers the final production. In the fast moving industrial world, automation is one of the essential elements for development and cost effectiveness. It helps to reduce the need for humans and increases the efficiency and productivity. The field of automation occupies large areas, mostly in industrial manufacturing and in addition to this; automation is applied to build a lot of sophisticated equipment which is used daily such as medical equipment X-Ray machines, radiography and refrigerators, automobiles, etc. Drilling robots provide the best alternative to the manual drilling. They cut human costs while improving the speed of production. Manual drilling can produce dust or other particles into the air during this

application process causing enormous health and physical issues. By using a robotic driller, the human worker is replaced by a fully automated, controlled system that saves time, cost and human errors with low risk of health aspects improving final production. Each drilling robot can be fitted with specialized end-of-arm- tooling (EOAT) that is fully customizable to specific drilling requirements.

Figure 1 shows the body diagram for mechanical design of the robotic arm. A robotic arm with only four degrees of freedom is designed because it is adequate for most of the necessary movement. At the same time, it is competitive by its complexity and cost-saving as number of actuators in the robotic arm increase with degrees of freedom. In a robotic system, the number of degrees of freedom is determined by the number of independent joint variable.

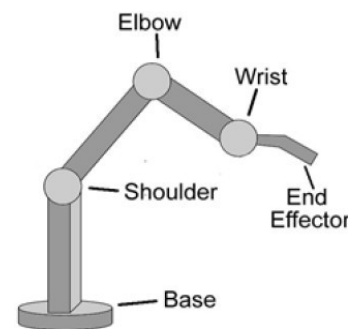

Fig 1. Robotic Arm system [1]

The word robot originated from the Czech word robot, meaning work. A definition used by the robot institute of America is: A robot is a programmable multifunction manipulator designed to move material, parts, tools, or specialized devices through variable programmed motions for the performance of a variety of tasks. In this highly developing society, time and man power are critical constrains for completion of task. The automation is playing important role to save human efforts in most of the regular and frequently carried work. The idea that machines can begin to imitate human actions, even in ways we have not thought of, the main motives for the creation of robot have been very practical. First, as modern industry has become more complex, there has been a growing need for getting work done in

environments that are dangerous for humans. As an example, work in a nuclear reactor plant often requires contact with radioactive materials. Second, as robots became more advanced and less expensive, they are being set up in industry situations where working conditions are not so much dangerous as unpleasant for various reasons. These situations typically involve high degrees of the following: - Heat, Noise, Poisonous gases, Risk of injury by machines, Monotonous, boring work. Robots have already taken over a number of such unpleasant jobs in industry- welding in automobile factories, which involves heat, noise and heavy exertion. Robots are obedient, untiring and precision welders. Simple robots do many routine jobs in industry. Pick and place robots are useful in simple assembly operations such as stuffing printed circuit boards and loading and unloading parts from machines [1][3][4].

II. LITERATURE SURVEY

There are various techniques to provide the solution for effective use of industrial appliances. In most of papers manual drilling used to operate the operation of industrial appliances. But this technologies have demerits over accuracy and productivity. As a result of the manual drilling has low accuracy and precise problem. In the Automatic robot drilling system this two problems are overcome and also increase the productivity.

This paper Dr. Bindu A Thomas, discuss about the Industry Based Automatic Robotic Arm [1]. The use of industrial robots is increasing in areas such as food, consumer goods, wood, plastics and electronics, but is still mostly concentrated in the automotive industry. The aim of this project has been to develop a concept of a lightweight robot using lightweight materials such as aluminum and carbon fiber together with a newly developed stepper motor prototype. The wrist also needs to be constructed for cabling to run through on the inside. It is expensive to change cables and therefore the designing to reduce the friction on cable, is crucial to increase time between maintenance. A concept generation was performed based on the function analysis, the the specifications of requirements that had been established. From the concept generation, twenty-four sustainable concepts divided into four groups (representing an individual part of the whole concept) were evaluated.

This paper S. Perumal discuss about the Design and Fabrication of Multi-Purpose hand drilling Machine [2] Drilling is a metal cutting process carried out by a rotating cutting tool to make circular holes in solid materials. Tools which makes hole is called as drill bit and twist drill. A power operated machine tool which holds the drill in its spindle

rotating at high speeds and when actuated move linearly against the work piece produces a hole. But it has some disadvantages like accuracy and precision.

This paper Kaushar H. Barad discuss about the Automation of conventional radial drilling machine [3]. it is required to do marking on the work piece. This may raise a problem due to error in marking by operator. Accurate marking is possible but it will require more time which will ultimately reduce the production rate. If marking has no error, then also it is required to set the drill to the center of the hole. This also can do addition to the error. So, automated motion of the radial arm and carriage is required. For drilling symmetric holes in the work-piece, one has to do marking on the work-piece which is error producing process. For a number of jobs it is also tedious. Moreover for the marking process, we need a separate labor which ultimately leads to increase cost of final product. The alternate option is to make a jig of required shape dimensions which is costly difficult to make. While using the jig we need to arrange it properly on the work piece which increases the setup time and it is repeated for every work piece. It will reduce production rate. For different number of holes dimensions we have to make separate jig which results further increase in cost per unit. For less no. of work piece the making of jig is not appreciable because of high cost of jig. To make such an arrangement on radial drilling machine which can reduce the time consumed in marking the center of hole on the work piece or can prevent the requirement to make jig which is costly and difficult to make

This paper Rahul Gautam is discuss about Review on Development of Industrial Robotic Arm [4] A robotic arm is a robotic manipulator, usually programmable, with similar functions to a human arm. Humans pick things up without thinking about the steps involved. In order for a robot or a robotic arm to pick up or move something, someone has to tell it to perform several actions in a particular order from moving the arm, to rotating the wrist to opening and closing the hand or fingers. So, we can control each joint. This paper presents a three joint automatic robotic arm which can be used in industries to do repetitive task such as moving the things from conveyor to another place, a sensor will be used to detect the obstacles if present while carrying out the task. If there is any obstacle while moving the object, the arm will wait for a predefined time for the clearance of the object. If the obstacle is cleared, the arm will continue its work. If the obstacle is still present, a buzzer will be turned on so that personnel from the industry can attend the problem and clear the obstacle.

This paper Yousef M. Abuejela aimed to design and fabricate an automated drilling machine based on PLC [5] to produce holes (8mm depth) in the center of a cubic work

pieces (3 cm 2 cm 3cm). The drilling machining process proposed for a cycle of drilling. The cycle process is start when the start switch is pressed; the linear motor is put in place the drilling head in home position, and rotate the rotary disk to bring the first work pieces to desired position. Meanwhile, the drilling process is running after the inductive sensor in the (desired position) sense the object. Then the process will stop automatically when made the hole and went back to the homeposition, after that the rotary disk start to rotate quarter cycle to carry the drilled object out the table during the lower rotary disk. The PLC used to perform these operations, by reading data from sensors and actuate the DC motors. At the end of this project, the result shows that the designed system was able to run the drilling process autonomously for three object per minute based on the desired sequence.



Fig 2 Robotic arm based machine using PLC [5]

III. PROPOSEDARCHITECTURE

The proposed system of our project is as shown above. The different components involved in our project are: robot-controller, two servo motors, object sensor, buzzer, PC Interface. In the proposed system the robot - controller which is KPM-2 is a high integrated functional computer system-on-a-chip. It contains an integrated memory and programmable input/output peripherals. Robot-controllers often operate at very low speed. They consume relatively little power. It is used to controls the motor activation and deactivation operations and also reads sensor signals. The Object sensor is used to sense the object and pass the detected signal to the robot-controller. The servo motor is containing the motor as well as the motor driver circuit. Here we do not use the extra motor driver IC or motor driver circuit. Motor driver is a little current amplifier, the function of motor drivers is to take a low- current control signal and then turns it into a higher-current signal that can drive a motor. In this project the three servo are used for the various application that are for the horizontal movement of robotic arm, second for the vertical

movement of robotic arm and end effectors is used for the to operate the fixture which is drilling mechanism is connected.

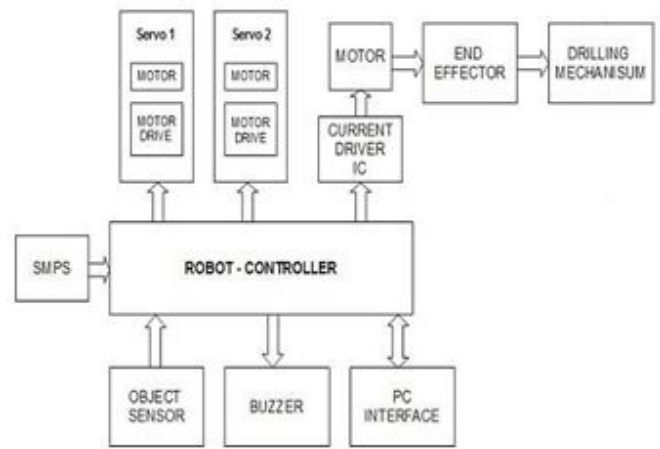

Fig. 3 Proposed System

1. ROBOTCONTROLLER(KPM-02):

A robot-controllers a high integrated functional computer system-on- a-chip. It contains an integrated memory and programmable input/output peripherals. Robot- controllers often operate at very low speed. They consume relatively little power. It is used to controls the motor activation and deactivation operations and also reads sensor signals. Here the use of robot controller is to controls the motor activation and deactivation operations and also reads sensor signals

Threaded processor for controlling 2 servo motors

- All outputs Servo + USBREGULATED
- Paralleladder
- Cycle execution Time : 1MIPS (Million Instructions per Second)
- Connectivity toComputer

2. MOTORS (KPM-1):

An electric motor is an electromechanical device that converts electrical energy into mechanical energy. Electric motors can be powered by direct current sources, such as from batteries. Robot- controllers command these motors through the driver circuit to take the necessary action.

- High torque(8 Kgcm)approx
- Double ball bearing to outputshaft
- Metalgears
- Operating Voltage: 5- 6VDC
- Current Consumption:1000mA
- Wattage:6W
- TEMP RANGE: -10 Deg to 60 DegCelcius.

- Velocity: 0.14Sec/60Deg
- Weight: 100 Gmsapprox

- The lead wire type(PS1550L40N) with both-sided adhesive tape installed easily isprepared.

3. OBJECT SENSOR (HC-SR04):

There we are using the ultrasonic sensor for the sensing the object. Power the Sensor using a regulated +5V through the Vccad Ground pins of the sensor. The current consumed by the sensor is less than 15mA and hence can be directly powered by the on board 5V pins (If available). The Trigger and the Echo pins are both I/O pins and hence they can be connected to I/O pins of the robot-controller. To start the measurement, the trigger pin has to be made high for 10uS and then turned off. This action will trigger an ultrasonic wave at frequency of 40Hz from the transmitter and the receiver will wait for the wave to return. Once the wave is returned after it getting reflected by any object the Echo pin goes high for a particular amount of time which will be equal to the time taken for the wave to return back to the sensor. The amount of time during which the Echo pin stays high is measured by the MCU/MPU as it gives the information about the time taken for the wave to return back to the Sensor. Using this information the distance is measured as explained in the above heading.

- Operating voltage:+5V
- Theoretical Measuring Distance: 2cm to450cm
- Practical Measuring Distance: 2cm to80cm
- Accuracy:3mm
- Measuring angle covered:15
- Operating Current:15mA
- Operating Frequency:40Hz

4. BUZZER:

A buzzer or beeper is an audio signaling device, which may be mechanical, elector mechanical, or piezoelectric [piezoelectric for short]. Typical uses of buzzers and beepers include alarm devices, timers, and confirmation of user input such as a mouse click or keystroke. here buzzer is used when drilling process is been completed.

- The PS series are high-performance buzzers that employ uni-morph piezoelectric elements and are designed for easy incorporation into variouscircuits.
- They feature extremely low power consumption in comparison to electromagneticunits.
- Because these buzzers are designed for external excitation, the same part can serve as both a musical tone oscillator and abuzzer.
- They can be used with automated inverters. Moisture- resistant models are alsoavailable.

IV. METHODOLOGY

In this project, we are using two servo motors each of which can be controlled by current driver IC. Here, two reference positions are chosen. First reference position is where the arm has to drill on the object and second reference position is the place where the robot has to stop the drill. First the robot-controller signals the servomotor-1 via driver circuit one to make the rotation of the arm to the desired direction. Then the signal from robot- controller is given to driver circuit 2 to drive the 2nd servomotor so that it can make up and down movement. Next End effectors which is situated at the gripper is activated so that gripper holds the drill mechanism. Next, servomotor-1 is again activated to turn the motor towards destination direction, motor is then activated to make the down movement of the arm and finally, gripper motor is activated to drill on the object. An Object sensor, which is connected to the robot-controller, is programmed such that it senses the presence of the object. If no object found then buzzer will be buzzed out for the indicating the process iscompleted.

In the industrial design field of human-machine interaction, the user interface is where interaction between humans and machines occurs. The goal of interaction between a human and a machine at the user interface is effective operation and control of the machine, and feedback from the machine which aids the operator in making operational decisions. A user interface is the system by which people (users) interact with a machine. The user interface includes hardware (physical) and software (logical) components. User interfaces exist for various systems, and provide a means of:

- Input, allowing the users to manipulate asystem.
- Output, allowing the system to indicate the effects of the users' manipulation.

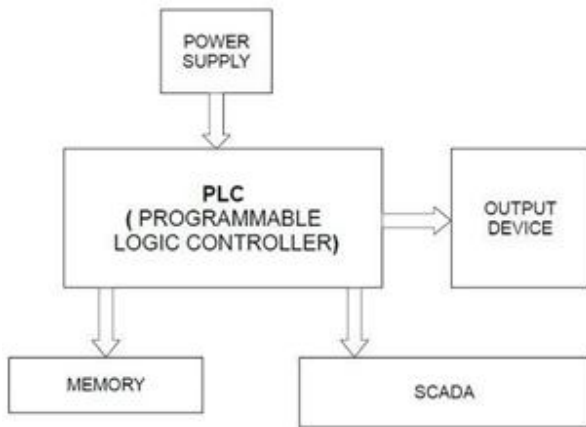

Fig. 4 Interfacing with the computer

After completion of the model of the automatic drilling robot and selection of programming language both should be interfaced. The interfacing of robot and computer using the software is the most important thing in the project. It should be interfaced using trial and error method, and then final movement should be set using the software's. The movement of robot should be precisely managed causing no harm to the operator.

Here we are use the PLC i.e., programmable logic controller are used for continuously monitoring the input values from sensor and produces the output for the operation of actuators based on the program. SCADA is a control system architecture that uses computers and PLC to interface with the process plant or machinery for management and operating .The operator interfaces that enable monitoring and issuing of process commands, such as controller set point changes, are handled through the SCADA computersystem.

V. WORK FLOWDESIGN

The work-flow design of proposed system is shown in the Figure. First initialize the computer then press the start button which is present on the computer screen. After sending the signal robot will wait for the signal. After receiving the signal robot will start the moving. Robotic arm will be move on in downward side for a specific time then it make a drill on the object then it is move in upward direction, and wait for a another signal. In the another side when drill is make the counter will be automatically updated on the computer screen. If signal is not received then robot will stop the operation . And if signal is received then it perform the next operation.

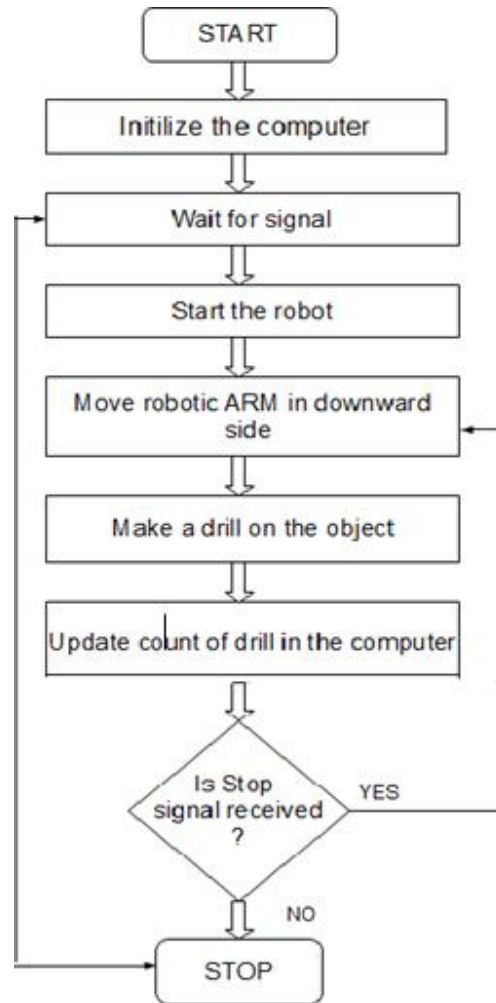

Fig. 5 Work flowdesign

VI. CONCLUSION

The social value of robotics is that these wonderfully subservient machines will permit humans more time to do work that is more challenging, creative, conceptual, constructive and co-operative than at present. There is every reason to believe that the automation of work through robotics will lead to substantial increases in productivity, and that these productivity increases year by year will permit humans to engage in activities that are cultural and recreational.

REFERENCES

- [1] Rahul Gautam, AnkushGedam, Ashish Zade, Ajay Mahawadiwar, “ Review on De- velopmentof Industrial Robotic Arm ”,Patil College Of Engineering, Nagpur, Maha- rashtra, IndiaPatil College Of Engineering, Volume 4, Issue 3, Mar-2017.
- [2] S. Perumal, T. Manikandan, K. Mounaraj, S. Mubarak, “ Design and Synthesis of Multipurpose Hand Driller Machine for Various Processes”, Department of Mechan-

- ical Engineering Department of Mechanical Engineering Muthayammal Engineering College (Autonomous), Volume 4, Issue 3, September 2017.
- [3] Yousef M. Abueejela, A. Albagul, Ibrahim A. Mansour and Obida M. Abdallah, "Automated Drilling Machine Based on PLC.", College of Electronic Technology, Volume 2, Issue 3, March 2015.
- [4] Dr. Bindu A Thomas, Stafford Michahial, Shreeraksha.P, Vijayashri B Nagvi, "Industry Based Automatic Robotic Arm", Institute of VidyaVikas Engineering and Technology, Volume 2, Issue 11, May 2013.
- [5] Kaushar H. Barad, Mukesh A. Balsara, Giriraj J. Patel, and Saurin M. Sheth, "Automation of conventional radial drilling machine", U.G. Student, Mechatronics Engineering, G. H. Patel College of Engineering and Technology, March, 2009.
- [6] <http://www.microrobotics.co.uk/>
- [7] www.allaboutrobotics.com.
- [8] <http://robotics.eecs.berkeley.edu/i-robot.html>
- [9] Prof. Dr. G.M. Phade, "Design of Electronics Stethoscope and Heart Rate Monitor for Remote Application", International Journal of Computer Applications in Technology 973-93-20891-43-82016.
- [10] Prof. Dr. G.M. Phade, "Serial port to Ethernet Real Time Data Communication Using Embedded System with ST16C554D", IEEE International Conference in Engineering & Technology International 2016.
- [11] Prof. Dr. G.M. Phade, "Motion Estimation for Human-Machine Interaction", Proceedings on 2014 IEEE International Symposium on Signal Processing and Information Technology (ISSPIT), Jaypee Institute of Information Technology, Noida, India.
- [12] Prof. Dr. G.M. Phade, "Real Time Street Light System Using Low Power Micro-controller", Springer International Conference on Communication and Networks (COMNET 2016) : International, Ahmedabad, Gujarat.