

# Improvement of Power Quality And Voltage Control Using FACTS:- A Review

Mr.Manoj R.Wankhade<sup>1</sup>, Prof.Ankita S.Borban<sup>2</sup>, Prof.Yogesh P.Sushir<sup>3</sup>

<sup>1</sup>Dept of Electrical Engineering

<sup>2,3</sup>Assistant Professor, Dept of Electrical Engineering

<sup>1, 2, 3</sup> Padm.Dr.V.B.K.C.O.E.Malkapur, Maharashtra(India)

**Abstract-** The traction system is the main fact of the distribution block. It is gives the major impact on the voltage control and the power quality problems during operation .This paper is deals with the voltage control and power quality of power maintenance. The traction system powered from the distribution sector such as power station .Which is able to providing the power to next consumers to compensate and maintain proper voltage and power quality. Here used some FACTS devices which are reducing the tripping causes, harmonics, which are oftenly present at abnormal condition. The compensation or FACTS devices like SVC, TCR are used as the controlling devices.

**Keywords-** Static Var Compensator (SVC), FACTS devices, Traction System, Distribution network, Voltage regulation.

## I. INTRODUCTION

The traction system is perform the major role in transportation of citizen and also the goods for import and export so it is helps in currency of country. Some technical issues like voltage disturbance and the power quality problems like voltage swell, sag, harmonics, interruption and some other issues regarding with the power system. If the power quality problems are removed then the system is get improved and gives the better output. Here we studied the paper which gives the locomotives observation move in particular power substation the substation is providing the power of 25KV to each sector of locomotive and produces capability of 220KV. If here we used some controlling or compensating devices for removed the harmonics or some technical issue forms the system. The system also removes the losses here some FACTS devices are used, out of this which are expensive but we used next devices to reduce such a problems.

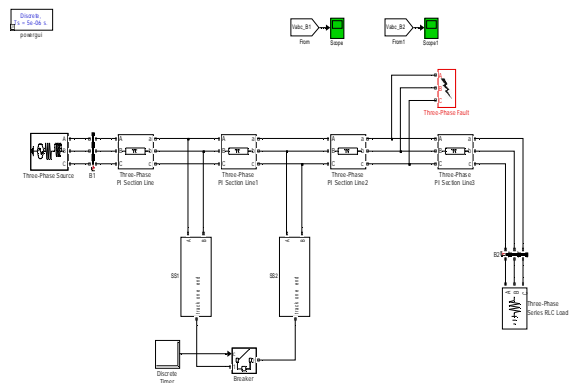

Fig 1:- Electrical Railway traction feeding system

The DC traction system which having the harmonic generation is the problem. Which is generates the variability on the demand. This review model is implemented also in MATLAB/SIMULINK.

The above fig shows the feeding system which is connected to the main sources which is thousands of Km long it is described in the distribution sector. Then her we considered the distance of 40-50 Km the substation, and then each of them is having capacity of generating 220KV. The system is implemented in Simulink so we take two substation and each having capacity to delivered 25KV to each locomotive and also two substation and two locomotive in each substation.then in that condition if the profile of voltage is get disturbed due to the fault then there will be introduced the compensator.

## II. LITERATURE REVIEW

Here we discuss the main literature of the voltage control and power quality. The system using FACTs devices the technical problem regarding voltage and power quality can be minimized following are some literature:

1. "Power Quality Control in DC Traction Systems using static VAR Compensator and Harmonics filter" by Rekha T and D.Bisharathu Beevi A describes the distribution system and result related to the sytem . here they also implemented in

MATLAB/SIMULINK and power quality problems were successfully replicated with the research model and here distortion problem can be minimized by using installation of SVC. And also using filters are removed the problems.

2. “Voltage Enhancement assessment using SVC FACTS controller” by Rajeev B R and G N Madhu this author explained voltage profile in power system due to increasing order of load which is concentrated on the reliable operation . This model is studied in the IEEE bus no 24 by using the SVC this are cleared the fault and optimized the system. This system is implemented in the PSCAD/EMTDC simulation software version 4.2

3. “Enhancement of power system stability using static Var Compensator” by N.P.Ghushe and U.A.Jawadkar explained the problems in the power system. Here the impact of FACTS device on stability and the contro of voltage stability on IEEE14 bus , the used of SVC is plys important role that to maintain stability improvement Here they shows the without any compensation system attained 85% of problem free and with compensation means used of SVC it having 95% of stability.

4. “Power quality improvement in railway traction using railway power quality conditioner” by John Jacob and E.K.Bindumol describes that here they used the v/v transformer for compensate the negative sequence and the high speed railways traction power supplied . the refererence current converter is used for maintained system in proper manner .they also introduced the energy balance equation to stable Dc link.

5. “Power Quality improvement in power system with FACTS Devices” by Mithilesh Singh and Shubhrata Gupta Described that the improvement reduces the losses and distortion in power system also I control the voltage stability thses all are under the FACTS devices this system is compared with optimization based on the various algorithms like newton’s algorithm etc.

### III. POWER QUALITY

The power quality is defined as, “According to IEEE”, the ability of the system to function satisfactorily in its electromagnetic environment without introduce any disturbances. Power quality actually refers to maintain a sinusoidal waveform of bus voltages at rated voltage and frequency. The power quality can be of poor power quality and good power quality.

#### Poor Power quality

Poor power quality generally means there is sufficient deviation in power supply to cause an equipment or process failure.

#### Good Power quality

Good power quality means that an equipment or process has sufficient power supply to operate satisfactorily without any disturbance. The equipment has designed a major determinant between good and bad power quality.

### IV. POWER QUALITY PROBLEMS AND EFFECT

As we know that, the mitigation of power quality problem takes place at different levels such as transmission, distribution and the end use of equipment. The supply system has to face power quality problems due to the extreme use of electronic equipment i.e. information technology equipment, adjustable speed drives (ASD), programmable logic controllers (PLC), energy sufficient lighting and LED has to change a complete electric loads nature. The non-linear loads are simultaneously the major causers and the major victim of power quality problems. There are various types of problems occurs in supply system or electric traction feeding system are explain here.

#### 1.Voltage Sags

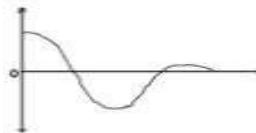

The voltage reduction in the supply voltage magnitude is followed by voltage recovery after a short period of time. These short duration voltages are called as “Voltage Sags”, or “Voltage Dips”. The major voltage dips faults are occurs in the system when starting of large loads.

#### 2.Very Short Interruption

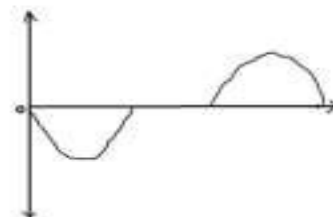

Very short interruption of electrical supply system for duration from few milliseconds to one or two second causes

tripping of protection devices, loss of information and also malfunctions of data processing equipment.

### 3. Long Interruption

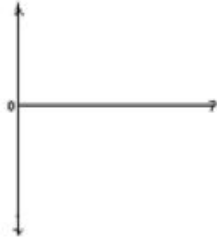

Long interruption of electrical supply occurs for duration of greater than one to two seconds causes stoppage of all equipment. The equipment failure is the main problem in the power system network, storms and object (e.g. trees, cars etc.) striking lines or poles, human error, fire, bad coordination or failure of protection devices.

### 4. Voltage Swell

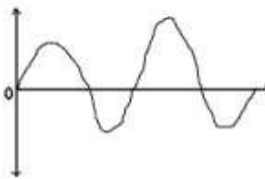

It is an increase in RMS value of electric supply voltage or current and its duration from 0.5 cycles to 1 min. The typical value of swell is between 1.1 to 1.8 pu. The main causes are start/stop of heavy loads and consequences are data lost, flickering of lighting and screens, stoppage or damage of sensitive equipment due to increase in RMS value.

### 5. Voltage Fluctuation

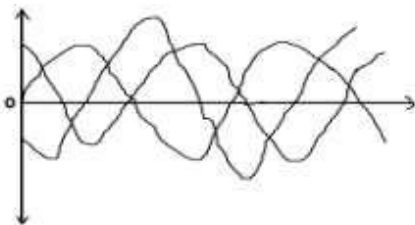

Due to the frequent start/stop of electric motors and oscillating loads consequences are under voltage, flickering of lighting and screens.

### 6. Harmonic Distortion

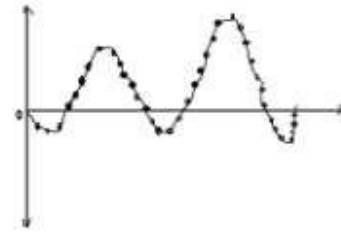

The increasing power quality concern is harmonics distortion that is caused by the non-linearity of loads. This concern has drawn attention from utilities, manufacturers of equipments and users.

### 7. Voltage Unbalance

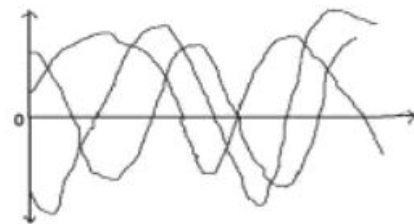

A variation of voltage in a three-phase system which shows the voltage magnitudes or the phase angle differences between them are not same. Due to these problems create large single-phase loads, incorrect distribution of all single-phase loads. The unbalancing of voltage generates negative sequence which is harmful to all three phase loads, specially most affected loads are three-phase induction machine.

## V. POWER QUALITY SOLUTION

For improving the power quality strategy following devices are play a crucial role. Such as

1. Distributed resources-Energy storage system or restoring technology.
  - a. Electrochemical battery
  - b. Flywheels
  - c. Super-capacitors
  - d. Super conducting magnetic energy storage (SMES)
2. Distributed resources-Distributed generation (DG) Units
3. Enhanced Interface Devices
  - a. Dynamic Voltage Restorers (DVR)
  - b. Transient Voltage surge suppressors (TVSS)
  - c. Constant Voltage Transformers (CVT)
  - d. Noise Filters
  - e. Isolation Transformer
  - f. Harmonic Filters
  - g. Static VAR Compensator

The above all devices are used for improving the power quality. But rather than these FACTS devices are most reliable for the better achievement. So the FACTS devices explain in FACTS Technology.

**VI. FACTS TECHNOLOGY**

The FACTs devices (Flexible AC Transmission System)is the development in the power electronics .The FACTS devices creates the fast response and improves the system output. It is the new integrated technology which involved the power electronics controlled devices the devices controller are mainly categorized such as the series controller ,shunt controller and series-shunt controller. The devices are like SVC (Static Var Compensator), STATCOM(Static compensator), TSC(Thyristor series controller (TCSC) and UPFC(Unified power flow controller).By using the compensator and the technology we can improves the power quality and the other parameter for reliable operation.

**A. STATCOM**

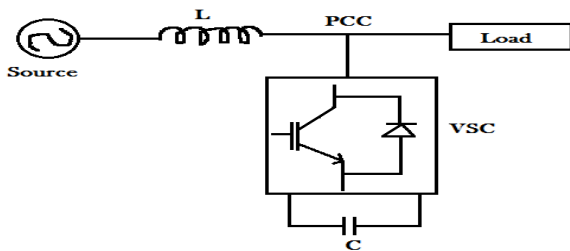

**Fig 2:-STATCOM Model**

STATCOM is connected across battery energy storage system. It is a voltage source shunt compensative converter. It is a reactive power compensative device which is absorb and delivered reactive power to the grid. At point of common coupling (PCC) the output can be varied for controlling specific parameter of the grid. At point of common coupling voltage source connected through inductance of the coupling transformer. The input ripple current which is carries by dc capacitor.

**B. UPQC**

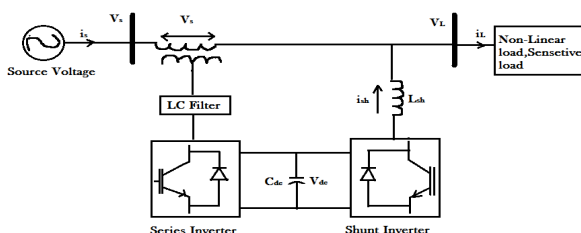

**Fig 3:-UPQC Model**

The UPQC has been used for improving power quality on power distribution systems or industrial power system. A common dc link which is provided by dc storage capacitor and it is the combination of STATCOM and series compensating devices.

**VII. CONCLUSION**

From this study we observed that, Static compensator gives better performance using various control technique for enhancing the performance of network. SVC used for the stabilization of voltage and UPQC plays important role to maintained power quality at point of common coupling but only defect is cost effective. It conclude that Use of the compensator is improved the stability, increased system security, reliability, flexibility. The compensators are used in distribution for decreasing the harmonics and loading. It prevents the section which are important in power system such as generation transmission and distribution. The observation of harmonic analysis can be prove that the distortion in voltage is less in voltage of locomotive while using the compensator.

**REFERENCES**

- [1] “Power Quality Control in DC traction system using static VAR compensator and harmonics filters” Rekha T ,Dr.Bisharathu Beevi A, vol 3 Issue 10 In October-2014.
- [2] “Voltage Enhancement assessment using SVC FACTS Controller” Rajeev B R , G N Madhu ,Vol-2 Issue-10 October 2014.
- [3] “Enhancement of Power System Stability Using Static VAR Compensator (SVC)”,N.P.Ghushe , U.A. Jawadekar, Vol-5 Issue-8 August 2017.
- [4] “Power Quality Improvement in Railway Traction Using Power Quality Conditioner” John Jacob and E.K.Bindumol in 2013.
- [5] “Power Quality Improvement in Power System With FACTS Devices” Mithilesh Singh, Shubhrata Gupta Vol-6 Issue 2 september 2017
- [6] “Power quality problems and new solutions”, A. de Almeida , L. Moreira. J. Delgado in ISR, Vol.1, April 2003
- [7] “An overview on power quality issues in power systems”, Ms. Ankita A. Yeotikar, Swapnil B. Mohod, IRJET, Vol.3, Issue:11, Nov-2016
- [8] “Power quality problems and solutions :an overview, IJSR, Mehebab Alam, Mandela Gain, Vol.03, Issue:10,Oct-2014
- [9] "Compensation for the negative-sequence currents of electric railway based on SVC", Guiping; Chen Jianye;

- Liu Industrial Electronics and Applications, 3rd IEEE Conference on, on page(s): 1958 – 1963, 2008
- [10] "Reduction method of high harmonic currents on the AC side of the diode rectifier circuits in the AC electric railways", Tokio Matsushashi, Kazutaka Itako, Takeaki Mori and Susumu Ohya, Industry Application Society Annual Meeting, vol.2, pp.1343-1350, 4-9 Oct., 1992
- [11] "Compensation of voltage drop using static Var compensator at sectioning post in electric railway system", Kenji Hawahara, Shin-iche Hase, Yoshifumi Muchinaga and Yasuji Hisamizu, Power Conversion Conference - Nagaoka, 1997, Proceeding of the Volume 2, 3-6 Aug. 1997, pp955-960
- [12] "Modelling of electric railway vehicle for harmonic analysis of traction power-supply system using Spline interpolation in frequency domain", K.H.Yuen, M.H.Pong, W.C.Lo and Z.M.Ye, Applied Power Electronics Conference and Exposition, Vol.1, pp458-463, 14-18 March 1999
- [13] "The application of SVC for the power quality control of electric railways", Ma Jianzong; Wu Mingli; Yang Shaobing, Sustainable Power Generation and Supply, International Conference on, On page(s): 1-4; 6-7 April 2009
- [14] "Reactive Power and Harmonic Distortion Control in Electric Traction Systems" J. Martinez, G. Ramos IEEE/PES Transmission and Distribution Conference and Exposition: Latin America, 2010
- [15] "Power Quality Improvement of DC Electrified Railway Distribution Systems Using Hybrid Filters", S. H. Hosseini, F. Shahnia, M. Sarhangzadeh, E. Babaei, in Proc. Electrical Machines and Systems, 2005. ICEMS 2005. Vol. 2, No. 2, pp. 1273-1277, Oct. 2005.
- [16] "More Intelligent DC Railway Electrical Power Systems with Power Traction Control" R. Takagi, S. Sone, Electrical Engineering in Japan, Vol. 114, No.7, pp. 91-101, 1994.
- [17] "Power Quality Disturbances Due to Interaction between AC and DC Traction Systems", L. Battistelli, P. Caramia, G. Carpinelli, D. Porto. IET International Conference on Power Electronic, Machines and Drives PEMD. Vol.2 pp. 492-497, 2004.
- [18] "Understanding FACTS Concepts and Technology of Flexible AC Transmission Systems", N. G. Hingorani, L. Gyugyi Wiley- IEEE Press 1999
- [19] "Harmonic disturbance compensating and monitoring in electric traction system", A. J. Ghanizadeh, S. H. Hosseinian, G. B. Gharehpetian, Vol 2, No 3, ELELIJ August 2013.
- [20] "Reactive Power Control in Electrical Systems", "T.J.E Miller Wiley (India), 20
- [21] "A STATCOM-control scheme for grid connected wind energy system for power quality improvement", Sharad W. Mohod and Mohan V. Aware, IEEE Systems Journal, Vol. 4, No. 3, pp. 346-352, 2010.
- [22] "Power Quality Enhancement Using Custom Power Devices", Arindam Ghosh and Gerard Ledwich, Springer, 2009.
- [23] "A STATCOM-control scheme for grid connected wind energy system for power quality improvement", Sharad W. Mohod and Mohan V. Aware, IEEE Systems Journal, Vol. 4, No. 3, pp. 346-352, 2010.
- [24] "Application of DSTATCOM for improvement of Power quality using MATLAB simulation" Archana M. Kadam, Satyen Dhamdhere, D.S. Bankar, International journal of science and modern engineering, volume-1, 2012
- [25] Rating requirements of a Unified power Quality Conditioner for voltage ride through capability enhancement" N.G. Jayanthi, malabikabasu, M.F. Conlon, K. Gaughan 3rd IET International conference on power electronics machines and drives, 2006
- [26] "Understanding FACTS: Concepts and Technology of Flexible AC Transmission Systems", Narain G Hingorani and L. Gyugyi, Wiley India, 2011.
- [27] "FACTS Controllers in Power Transmission and Distribution" by K R Padiyar, New age International Publishers, ISBN (13) : 978-81-224-2541-3
- [28] "Voltage Stability Improvement using Static Var Compensator in Power Systems"- by Mark Ndubuka NWOHU, Leonardo Journal of Sciences Year 2009, Issue 14, ISSN 1583-0233, Page no: 167-172
- [29] "Voltage Control and Dynamic Performance of Power Transmission System Using Static Var Compensator", Nang Sabai, Hnin Nandar Maung, and Thida Win World Academy of Science, Engineering and Technology 42 2008.
- [30] "Optimal location of SVC and TCSC for voltage stability enhancement" by Bekri, O.L. & Fella, M.K., published in IEEE 4th International Power Engineering and Optimization Conference (PEOCO), 2010 23-24 June 2010
- [31] "Studies of Voltage Stability Based on SVC Control" by Baochun Lu & Baoguo Li; Yi Liu; Weiguo Guan; Gang Lv, published in IEEE 3rd International Conference on Innovative Computing Information and Control, 2008.
- [32] "Power quality Enhancement using FACTS devices", A. Nabisha, S. Marshelino, Dr. X. Felix Joseph, International Journal of Interdisciplinary Research (IJIR), Vol-2, Issue-12, 2016
- [33] "Power quality Improvement using FACTS devices (STATCOM)", G. Shrinivas, T. Santosh Chaitanya, ISSN, Vol-2, 2015