

Determination of Weakest Bus And Its Ranking In Large Power Distribution System And Optimal Allocation of Facts Device

Satyapal¹, Subhash²

¹Dept of Electrical

²Assistant Professor, Dept of Electrical

^{1,2}Sobhasaria Group of Institutions Sikar, India

Abstract- *The Unified Power Flow Controller (UPFC) is a typical FACTS (Flexible AC Transmission Systems) device that is the most sophisticated and complex power electronic equipment and has emerged for the control and optimization of power flow and also to regulate the voltage in electrical power transmission system. This paper propose the real, reactive power and voltage control through a transmission line by placing UPFC at the sending end using computer simulation. The L index is the parameter which is used to check the stability. Voltage stability is concerned with the ability of a power system to maintain acceptable voltages at all buses under normal conditions and after being subjected to a disturbance. The assessment of voltage stability has also become more complicated due to strengthening of power systems. The research work mainly dealt with performance analysis of IEEE-14 bus system for voltage stability, computation of voltage collapse point and enhancement of power system stability by using UPFC.*

Keywords- UPFC, LINE STABILITY INDEX, FAST VOLTAGE STABILITY INDEX voltage stability etc.

I. INTRODUCTION

The research work mainly dealt with performance analysis for voltage stability, computation of voltage collapse point and enhancement of power system stability by using UPFC of IEEE-14 bus system. The Unified power flow controller (UPFC) is the latest device in the FACTS family. Voltage sourced converter is used in the UPFC like it is used in the static synchronous compensator (STATCOM) and in static synchronous series compensator (SSSC) as a basic building block. There is a huge amount of work is done in the past for the modeling of the UPFC for the analysis of power flow analysis [2, 3, 14-20]. Normally the UPFC is used to compensate a single transmission line. To control power system voltage stability we can use many methods. The research is made on the basis on analytical methods such as dynamic simulations and load-flow algorithms. The computation of the voltage stability margin is a lengthy

process but this is the most useful method for determination of voltage stability. There are many computation methods developed for voltage stability analysis and in principle they are best suited for power system planning. On-line voltage stability assessment is also based on these computation methods.

In the dissertation for on-line long-term voltage stability assessment an analytical approach is developed. The function to be approximated is the mapping between the operating point before disturbance and the voltage stability margin of the most critical congestion. Active and reactive line flows and bus voltages which are commonly measured in most power systems from almost all lines and buses are the inputs for voltage stability assessment. The congestion can affect the, unit commitment, changes in the power system load, production, network topology, etc.

The idea of the approach is to expand and generalize the existing and widely used line voltage stability limit “L-index” method and to determine the uncertainty related to power system operation. The line voltage stability index is used to take into account the voltage stability condition in the system. The PV curve is used to determine the power system security limits, if more accurate and up-to-date security limits are used then the power system security limits can be increased in some situations without the fear of insecurity. Due to the previous reasons the power system cannot be stressed up to maximum limit but when the security boundary method is applied a relatively large reliability margin is needed. This margin is hardly a few per cent of total capacity. To allow increased power to transfers close to or beyond the security boundary, there should be a possibility to evaluate risks and uncertainties related to security limits.

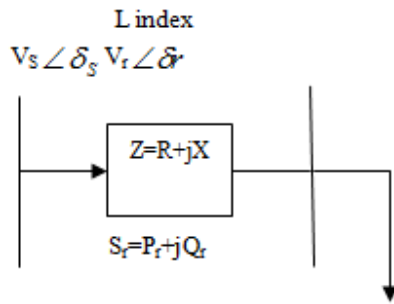

Fig1:- Two bus system

This index proposed by Moghavvemi in [14] is based on the model of power flow through a single line shown in Fig. 1 to which a power system network can be reduced, where the subindex S indicates the sending end and the subindex r denotes the receiving end.

$$L_{mn} = \frac{4Q_r X}{[V_s \sin(\theta - \delta)]^2}$$

This L_{mn} value is used to find the stability index for each line connection between two bus bars in an interconnected network. As long as the L_{mn} values of all pairs are less than 1 the system is considered stable.

II. UNIFIED POWER FLOW CONTROLLER (UPFC)

Basic principle of UPFC:

As in the figure show, UPFC consist of two back to back converters named VSC1 and VSC2, are operated from a DC link provided by a dc storage capacitor. These arrangements operate as an ideal ac to ac converter in which the real power can freely flow either in direction between the ac terminals of the two converts and each converter can independently generate or absorb reactive power as its own ac output terminal.

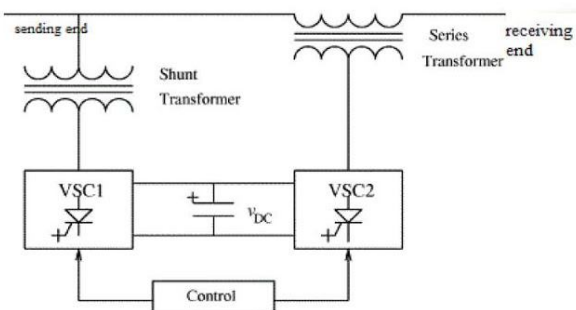

Fig2:- Principle of UPFC

One VSC is connected to in shunt to the transmission line via a shunt transformer and other one is connected in series through a series transformer. The DC terminal of two VSCs is coupled and this creates a path for active power exchange between the converters. VSC provide the main function of UPFC by injecting a voltage with controllable magnitude and phase angle in series with the line via an injection transformer. This injected voltage act as a synchronous ac voltage source. The transmission line current flows through this voltage source resulting in reactive and active power exchange between it and the ac system. The reactive power exchanged at the dc terminal is generated internally by the converter. The real power exchanged at the ac terminal is converted into dc power which appears at the dc link as a real power demand and VSC1 is to supply or absorb the real power demanded by converter2 at the common dc link to support real power exchange resulting from the series voltage injection. This dc link power demand of VSC2 is converted back to ac by VSC1 and coupled to the transmission line bus via shunt connected transformer. in addition, VSC1 can also generate or absorb controllable reactive power if it is required and thereby provide independent shunt reactive compensation for the line. Thus VSC1 can be operated at a unity power factor or to be controlled to have a reactive power exchange with the line independent of the reactive power exchanged by VSC1. Obviously, there can be no reactive power flow through the UPFC dc link.

III. DETERMINATION OF STABILITY OF BUSES

The test system for my research work is IEEE-14bus system (fig 3).

To maintain the quality of power it is very important to maintain the quality of voltage. There are basic two causes through which voltage stability of the system is threatened;

- One is contingency which aris edue to scheduled outage, component switching in order to optimize power system operation, or unscheduled outage due to a fault.
- Other is congestion; with increased electric power consumption causes transmission lines to be driven close to or even beyond their transfer capacities resulting in overloaded lines and congestions.

The basis of my study for voltage stability is congestion. Algorithm

Step(1) Load flow study is carried out for ieee14 (fig 3) bus system at base loading.

- Before load flow study was carried out, a better understanding of bus data , Line data, is done for understanding loading pattern, voltage magnitude, voltage angle, generation capacity, reactive power reserves, reactive power injection, line parameters, tap setting of transformer, etc.
- After this load flow study was done using Newton-Rapson Load Flow using MATLAB programming Results for bus data and line flow is shown in Table 1, 2,3
- At base case L-index is calculated using equation 3 for all 20 lines to predict the voltage stability condition in the system.

The load flow study helps in continuous monitoring of the present status of the system which in turn helps in tackling the following problem

1. The total amount of real and reactive power flow in the system.
2. Transmission links can carry certain amount of power and which should not be close to critical values.
3. It is necessary to keep the voltage levels of the certain buses within close tolerance' which is possible by proper scheduling of reactive power.
4. Load flow helps in finding out the power flow pattern through the system which is very helpful in assessing the voltage stability study.
5. By formulating suitable load flow mathematical model, load flow adequately describes the relationship between voltage and power.

Step (2) At the base case congestion is introduced by over loading the system in the steps of 10% and the system behaviour is studied.

- In the base case the line loading are done by increasing the load at the buses and the bus data are obtained by running the program .
- System behavior under these loading is studied by determining point of voltage collapse using L-index.

There are various methods of assisting voltage stability of the power system as;

- By enhancing generator reactive and active power control and voltage control,
- By incorporating suitable compensation device.
- By rescheduling of power system which involves load shedding and ATC calculation. This also known as The focus of my study was to analyze system behaviour during pre-congestion, during congestion

and post- congestion condition. To enhance system voltage study reactive power compensation technique is used in my dissertation work.

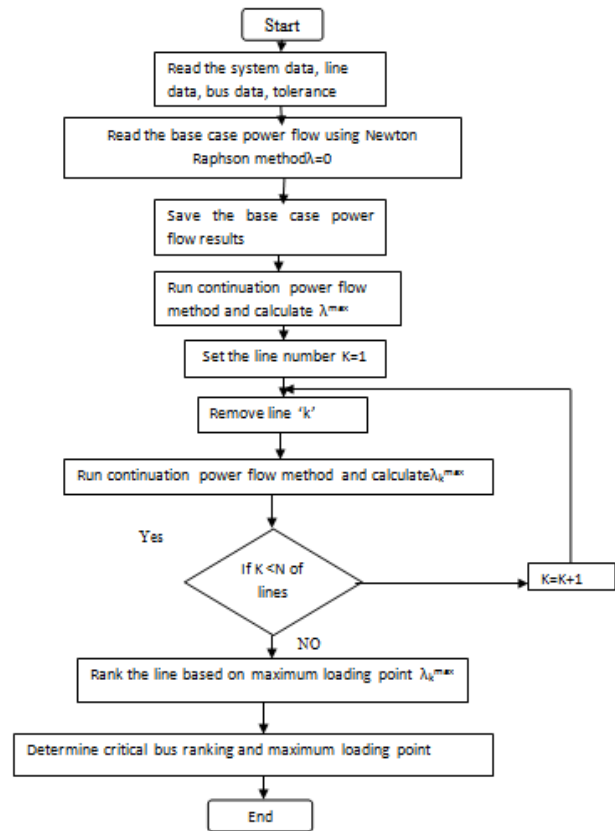

Fig2:- Flow chart for optimal power flow

Step(3) To resolve congestion in the system using UPFC.

- To enhance system voltage stability at the condition of congestion reactive power is boosted by connecting UPFC in accordance to the critical bus ranking.
- The result active and reactive power flow after the installation of UPFC Voltage profile of the system is studied when UPFC is connected.

L-index is calculated for the compensated system.

Maximum Loading Point in Power System (MLP)

The critical line is identified based on congestion ranking of IEEE-14 bus system by NR load flow method. The flowchart for the ranking of all possible congestions is as shown in figure 1. For each line outages conditions, the MLP would be calculated. The Maximum Mega Watt Margin (MMWM) and MW Margin (MWM) are calculated by using the following equations

Maximum Mega Watt Margin (MWM) = Pmax – Pbase

Mega Watt Margin (MWM) = Pimax - Pbase

Where, Pbase --- Base case Mega Watt loading.

Pmax --- Maximum Mega Watt loading during without line outage condition.

Pimax --- Maximum Mega Watt loading during each line outage of line i .

λ = line loadability factor

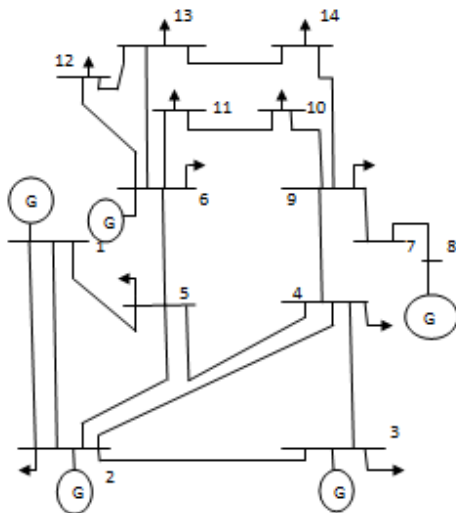

Fig 3:- IEEE 14 BUS SYSTEM

IV. L-INDEX FORMULATION

The Voltage Stability Index abbreviated by L_{ij} and referred to a line is formulated in this study as the measuring unit in predicting the voltage stability condition in the system. The mathematical formulation to speed up the computation is very simple.

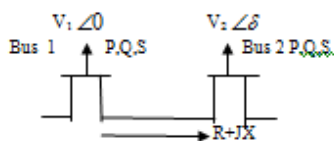

Fig. Two-bus power system model.

The L_{ij} is derived from the voltage quadratic equation at the receiving bus on a two bus system . The general two-bus representation is illustrated in the figure. From the figure above, the voltage quadratic equation at the receiving bus is written as

$$[V_2^2 - (\frac{R}{X} \sin \delta + \cos \delta)V_1V_2 + (X + \frac{R^2}{X})Q_2 = 0] \quad (1)$$

Setting the discriminant of the equation to be greater than or equal to zero:

$$[(\frac{R}{X} \sin \delta + \cos \delta)V_1]^2 - 4(X + \frac{R^2}{X})Q_2 \geq 0 \quad (2)$$

Rearranging Eq. we obtain

$$L_{ij} = \frac{4Z^2Q_jX}{V_i^2(R \sin \delta + X \cos \delta)^2} \quad (3)$$

Where:

Z = line impedance

X = line reactance,

Q_j = reactive power at the receiving end

V_i = sending end voltage

Solution Algorithm

The overall solution procedure for Newton-Raphson method with UPFC model can be summarized as follows.

- 1) Read the load flow data and UPFC data.
- 2) Assume flat voltage profile and set iteration count $K=0$
- 3) Compute active and reactive power mismatch. Also, the Jacobian matrix using NR method equations [12].
- 4) Modify power mismatch using UPFC mathematical model (5.4) - (5.15).
- 5) If the maximal absolute mismatch is less than a given tolerance, it results in output. Otherwise, go to step 6
- 6) Solve the NR equations; obtain the voltage angle and Magnitude correction vector dx .
- 7) Update the NR solution by $x=x+ dx$.
- 8) Set $K=K+1$, go to step 3

V. RESULTS

In my study IEEE-14 bus system has been analyzed for voltage stability and congestion management. All the load buses were over loaded one at a time with a multiplying factor of 10% in steps. Critical bus was identified as the decrease order of maximum loadability in context to the line voltage stability index, i.e. for the bus loading when index attain unity value that loading is the maximum loading for that bus and the bus which has minimum loading is the weak bus of the system and the line which attain unity value for the L_{mn} index is the critical line. For that bus the results are shown in the table 6.1, for both real power and reactive power loading 9,4,14 buses are identified as weak buses. 4-9, 1-5, 13-14 are consecutive

critical line. UPFC is connected to these lines to maintain stability of the system.

VI. CONCLUSIONS

In this dissertation work, the power system line outage analysis and contingency ranking is done based on the Maximum loading point. Here, load flow method is used to estimate the maximum loading point for each line outage conditions. It is observed from the results, the occurrence of line outage in power system results in increasing of voltage drop in some of buses, the possibility of change in the weakest bus position and change in MLP. The line outage with lower loading point has the higher ranks in the contingency ranking and identified as critical line. So, by identifying these critical line outages, we can take immediate necessary action to avoid the system voltage collapse and unwanted power system blackouts.

Table-1: Reduction in Losses

S. NO.	LOSSES	WITHOUT UPFC	WITH UPFC	% IMPROVEMENT
1	P _{LOSS}	100.210	94.766	5.44
2	Q _{LOSS}	349.670	326.374	6.66

Table-2: Improvement in L index

BRANCH NO.	VALUE OF L _{max}		% IMPROVEMENT
	WITHOUT UPFC	WITH UPFC	
1	0.1100	0.1121	-1.90909
2	0.9990	0.8519	14.72472
3	0.0691	0.0625	9.551375
4	0.6313	0.4097	35.10217
5	0.3514	0.2308	34.31986
6	0.4281	0.2823	34.05746
7	0.0208	0.0685	-229.327
8	0.2815	0.3312	-17.6554
9	0.1332	0.3314	-148.799
10	0.2481	0.1579	36.35631
11	0.1988	0.0380	80.88531
12	0.0694	0.0053	92.36311
13	0.1230	0.0112	90.89431
14	0.4145	0.2267	45.3076
15	0.1031	0.0405	60.71775
16	0.0306	0.0295	3.594771
17	0.0477	0.2481	-420.126
18	0.1505	0.0051	96.6113
19	0.0499	0.0386	22.64529
20	0.2131	0.2385	-11.9193

Table-3: Improvement in voltage profile

BUS NO.	VOLTAGE PROFILE		% IMPROVEMENT
	WITHOUT UPFC	WITH UPFC	
1	1.06	1.06	0
2	0.995	0.995	0
3	0.96	0.96	0
4	0.846	0.8799	-4.00709
5	0.879	0.9013	-2.53697
6	1.02	1.02	0
7	0.9364	0.9833	-5.00854
8	1.04	1.04	0
9	0.9113	0.9942	-9.09689
10	0.9183	0.9872	-7.50299
11	0.9625	0.9977	-3.65714
12	0.9913	1.0057	-1.45264
13	0.977	1.0042	-2.78403
14	0.9111	1.0309	-13.1489

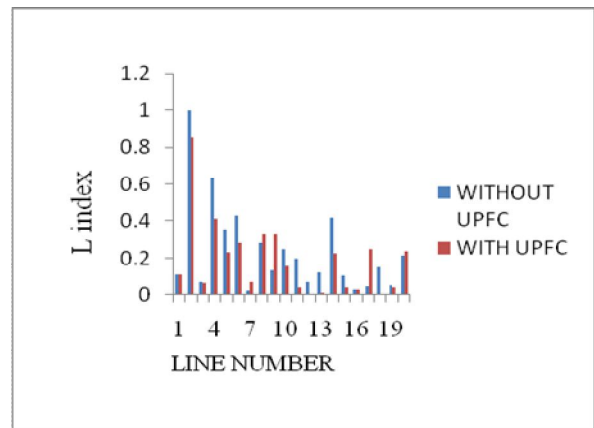

Figure-Comparison of L index

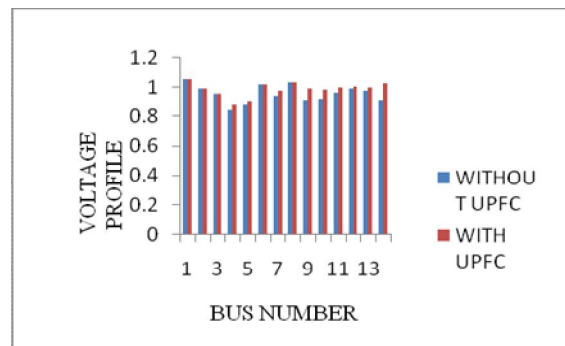

Figure-Comparisons of voltage profile

REFERENCES

- [1] M. Cupelli "Comparison of line voltage stability indices using dynamic real time simulation" 2012 3rd IEEE PES Innovative Smart Grid Technologies Europe (ISGT Europe)
- [2] M. H. Haque "A smart instrument for on-line monitoring of static voltage stability index using local measurements" 2013 IEEE Innovative Smart Grid Technologies-Asia (ISGT Asia)
- [3] Claudia Reis" Line stability indices for voltage collapse prediction" 2009 International Conference on Power Engineering, Energy and Electrical Drives

- [4] F. A. Althowibi” Voltage stability calculations in power transmission lines: Indications and allocations” Power and Energy (PECon), 2010 IEEE International Conference on
- [5] M. Ramesh” Stability of Power Transmission Capability of HVDC system using facts controllers” Computer Communication and Informatics (ICCCI), 2012 International Conference on
- [6] A. Murugan” A new approach for voltage control of IPFC and UPFC for power flow management” Energy Efficient Technologies for Sustainability (ICEETS), 2013 International Conference on
- [7] Ahmed A. Hossam-Eldin” Study and simulation of the unified power flow controller effect on power systems” Power Systems Conference, 2006. MEPCON 2006. Eleventh International Middle East (Volume:2)
- [8] K. Belacheheb” Compensation of the electrical mains by means of unified power flow controller (UPFC)-comparison of three control methods” Harmonics and Quality of Power, 2000. Proceedings. Ninth International Conference on (Volume:1)
- [9] Natália M. R. Santos “Incorporating a Unified Power Flow Controller in a conventional transient stability model” Control & Automation (MED), 2011 19th Mediterranean Conference on