

A Research Paper on Financially Intensive Solar Inverter

Avnish Kumar¹, Gaurav Shrivastava²

¹ B.Tech Student, Department of Electrical Engineering, Poornima College of Engineering, Jaipur

² Assistant professor, Department of Electrical Engineering, Poornima College of Engineering, Jaipur

Abstract- The financially savvy Solar is the most effective source of vitality, ecological accommodation and natural survival in nature. It is often transformed into electrical vitality in a financially savvy way. Recently, the enthusiasm for sunshine has risen. Because of the cost of oil pollution and natural attention. Direct access in many remote or immature areas the electronic matrix is unimaginable, the photovoltaic inverter frame will make life more difficult, and the sky is the limit there advantageous. With this in mind, it aims to configure, manufacture and test solar-based panel inverters.

Keywords- MOSFET – Metal oxide semi-conductor field effect transistor, PCS- Power conditioning system

I. INTRODUCTION

Sun based PV-based age has its disadvantages yet it's having more focal points to over shadow that downside. Along these lines in India and especially Gujarat having the capacity to create sun powered electrical power age sunlight based power age was expanded by 20 to 25% in last multi year. Sun based photovoltaic (PV) cells convert daylight specifically to power without poison emanation. This power age is affected by physical and ecological parameters, for example, the sunlight based radiation and cell temperature on PV cell. PV control provided to the utility matrix is increasing increasingly more consideration these days, henceforth different standard referenced by various framework observing experts are must be pursue. This standard are manages issues as power quality, identification of islanding task, DC current infusion and so forth. Diverse utility are pursue the distinctive guidelines which are rely upon the country, national strategy, sorts of utility, kinds of purchaser, control rating and so on. Various inverter circuits and control plans can be utilized for PV PCS. Be that as it may, contingent upon the attributes of the PV boards, the absolute yield voltage from the PV boards changes incredibly because of various temperature, light conditions, and shading and obfuscating impacts. In this way, the info voltage of a private PV inverter can fluctuate generally, for instance from 200 to 500V, and can be very not the same as the attractive 400-V level. Along these lines, a dc– dc converter with either venture up capacity or venture down

capacity or even both advance up and venture down capacities is required before the dc– air conditioning inverter arrange.

II. OPERATION OF SOLAR INVERTER



Fig.1 Block diagram of solar inverter

SOLAR PANEL: Sun based PANEL: A board intended to ingest the sun's beams as a wellspring of vitality for creating power or warming

RELAY: An electronic device that is typically connected to an electromagnet that is actuated by a flow or mark in one circuit to open or close another circuit.

DC-DC CONVERTER: It is usually a buck-boost converter whose yield voltage strength is more accurate or inaccurate than the information voltage range. It is proportional to a fly back converter that uses an isolated inductor instead of a transformer.

INVERTER: A mechanical assembly which changes over direct current into substituting current.

III. BUCK-BOOST CONVERTER

The normal yield voltage V_o is not more accurate or worthy than the information voltage V_s of the converter, it will be selected by estimating k , and its voltage condition is composed of the following. The converter's yield voltage has a

limit opposite to the information voltage, so it is called an inverting converter.

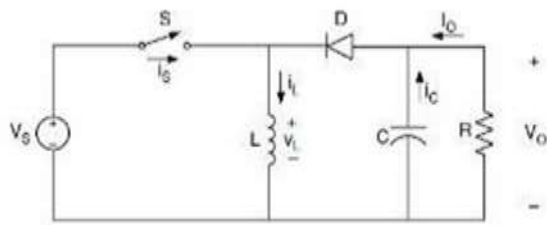

Fig.2 Basic schematic of a buck-boost converter

When $0 < K < 0.5$ -Converter works in buck mode. $0.5 < K < 1$ -Converter works in Boost mode.

$$V_a = V_s \frac{K}{(1-k)}$$

IV. OPERATING PRINCIPLEBUCK-BOOSTCONVERTER

The circuit is intended to accomplish most extreme effectiveness from the present parts and quality, and on the other to be as straightforward as could reasonably be expected, and be utilized for various purposes, for example,an undervoltage 24V vehicle. The starting point of the circuit is the 24V DC control connector CN1, CN2 and diode D1, allowing you to connect the circuit to either circuit. extremity. As a controller, for example, 7812, the circuit gives a stable energy of 12V to control the controller LM324, Pulse-width modulator (PWM) and a temperature controller. The PWM is responsible for adjusting the span of the rectangular heartbeat, at the output S1, S2, the current flag relative to the VSF yield circuit (yield voltage source) and the voltage of the information module terminals. These findings establish a positive input circular module. They generate voltage by changing the PWM trim. The estimation of the device P1 is implemented.

The temperature control module is responsible for keeping the temperature of the power MOSFET and the internal circuit reasonable [18], and the controller reduces the vitality and utilization of the fan by stopping when it is not needed. The power consumption depends on the controller of the MOSFET. This section contains everything needed for control and guidance of the power MOSFET in the circuit's semi-join. The PWM flag is coupled to the contact module IC1 via two diodes, the diode connects the two yield signals s1, s2 and a compensated resistor R3, the subsequent flag - a square wave, fixed recursive adjustment 70kGts span from 0 to a limit of 98 %, depending on voltage + 12V. Rectangular markers are enhanced intensifier stages T1, T2, T3, filtered

through inductor L2 to the high-inductance ferrite ring center, often used in power supplies, which are included in the channel yield symbol and voltage, beyond what many consider possible The scope. Eliminate high recurrence (high recurrence rate). DC disconnected voltage source. When the voltage at L1 is corrected by the accumulation of diode D10, D11 Schottky diodes, diode lock occurs with a little internal obstruction and uses a higher recurrence of operation when replacing the power supply. The end point of the chain is screened and balanced by the methods of electrolytic capacitors C10, C11. The final product has a stable top-level control supply voltage.

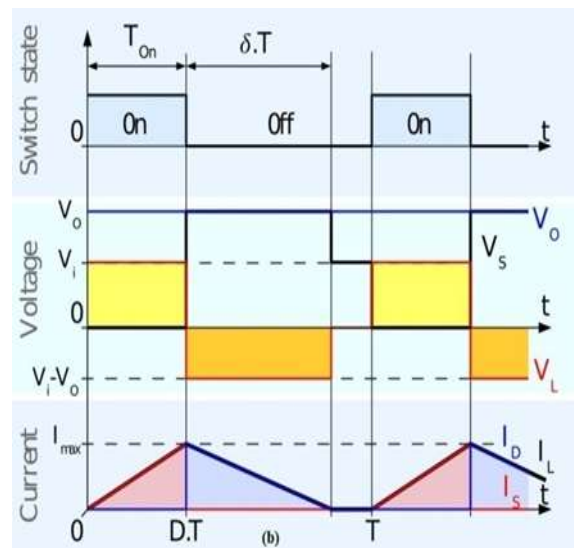

Fig.3 Waveforms of current and voltage in a boost converter operating in continuous mode

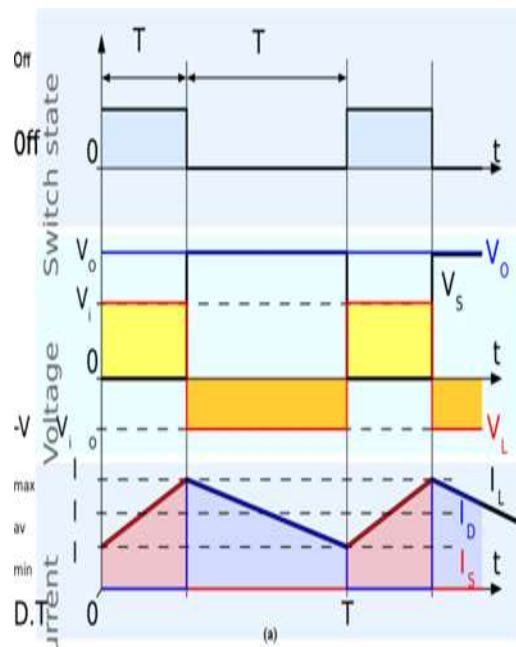

Fig.4 Discontinuous Mode Shown By Waveforms.

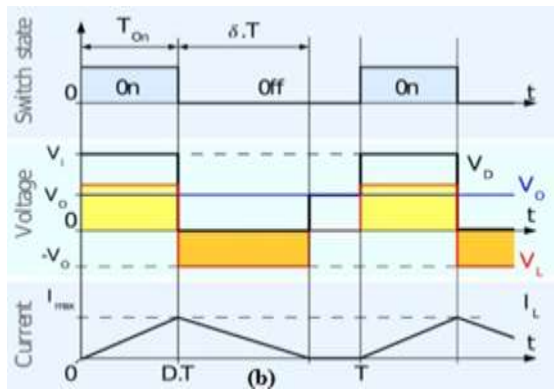

Fig.5 Current voltage continuous mode shown by waveforms.

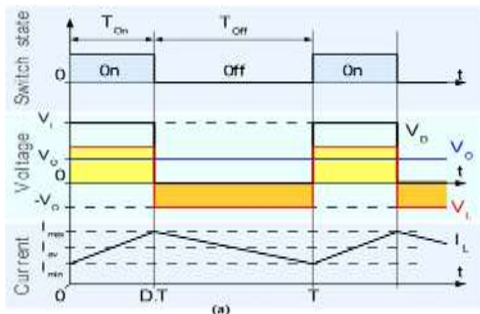

Fig.6 Discontinuous mode shown by waveforms buck converter

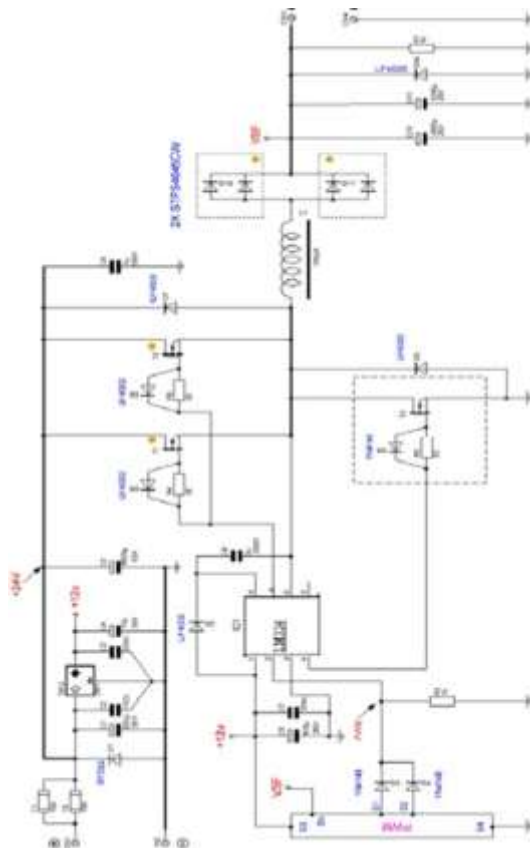

Fig.7 Circuit of buck boost converter

V. WORKING PRINCIPLE OF INVERTER

One of Tesla's inheritances (and that of his colleague George Westinghouse, supervisor of the Westinghouse Electrical Company) is that the vast majority of the apparatuses we have in our homes are explicitly intended to keep running from AC control. Apparatuses that need DC however need to take control from AC outlets need an additional bit of hardware called a rectifier, commonly worked from electronic segments called diodes, to change over from AC to DC.

An inverter does the contrary employment and it's very straightforward the pith of how it functions. Assume you have a battery in an electric lamp and the switch is shut so DC streams around the circuit, dependably in a similar heading, similar to a race vehicle around a track.

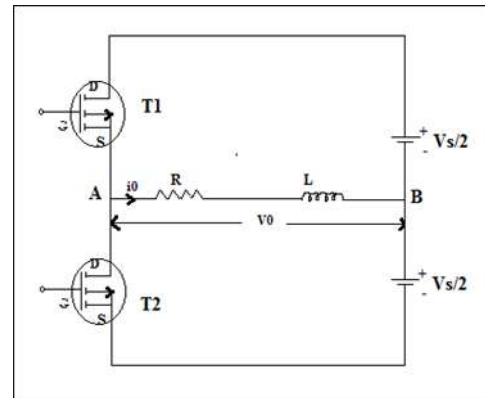

Fig.8 Single Phase half bridge Inverter

Figure 8 shows the circuit outline of a single-phase semi-expanded inverter with two MOSFETs T1 and T2 used as switching gadgets [22]. MOSFET T1 turns on 0 to $T / 2$. Therefore, the yield voltage is determined to be $V_s / 2$. In the above circuit, when current comes from A B in the stack, MOSFET T2 conducts from $T / 2$ to T, and T1 is turned on.

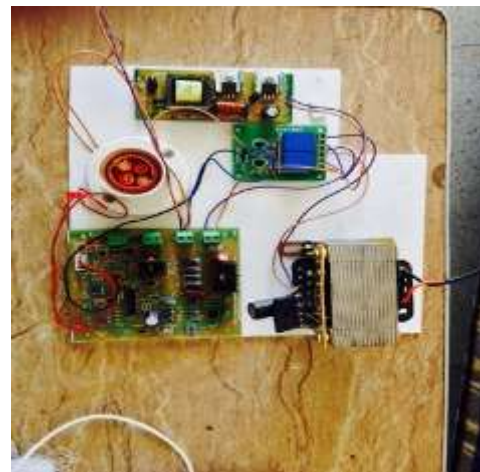

Figure 9 waveform of single-phase half-bridge inverter

VI. MEASURED PARAMETERS

| | | |
|---|-------------|---------------|
| 1 | i/p voltage | 12v(DC) |
| 2 | o/p voltage | 230v(AC) |
| 3 | i/p current | 0.83A |
| 4 | o/p current | 0.0217A |
| 5 | i/p power | 12*0.83=10w |
| 6 | o/p power | 230*0.0217=5w |

VII. CONCLUSION

A exalted productivity support buck converter based single lap PV inverter is expected. These principal converter division works in this one lift in this cross system; subsequently, it have a large info energy extend, that is useful for PV operation. The another inverter part is an unfolding circuit is formed according to the orientation of the matrix. Therefore, from the perspective of power processing, the inverter is a single-stage inverter. Since it forms a controller as a buck converter or a buck converter, high proficiency can be achieved.

Smaller capacitances suggest lower maximum power point tracking (MPPT) productivity. Therefore, at the end of the life of the electrolytic capacitor, the capacitor does not neglect work, but the adjustment of the capacitor reduces the productivity of the MPPT and also reduces the proficiency of the entire frame.

REFERENCES

- [1] Yi Huang; Miaosen Shen; Peng, F.Z.; Jin Wang; " Z-Source Inverter for Residential Photovoltaic Systems", IEEE Transactions on Power Electronics, Volume 21, Issue 6, pp. 1776 – 1782, Nov. 2006.
- [2] Kjaer, S.B.; Pedersen, J.K.; Blaabjerg, F.; "A survey of single stage framework associated inverters for photovoltaic modules", IEEE Transactions on Industry Applications, Volume 41, Issue 5, pp. 1292-1306, Sept.- Oct. 2005.
- [3] Salas, V.; Olias, E.; "Most extreme power point following in the PV framework associate inverters of 5 kW", Photovoltaic Specialists Conference (PVSC), 2009 34th IEEE, pp. 193 – 196.
- [4] J.M. Kwon, K.H. Nam, and B.H. Kwon, "Photovoltaic power molding framework with line association, " IEEE Trans. Ind. Electron., vol. 53, no. 4, pp. 1048-1054, Aug. 2006.
- [5] P. G. Barbosa, H. A. C. Braga, M. do Carmo Barbosa Rodrigues, and E. C. Teixeira, "Lift current staggered inverter and its application on single-

- stage network associated photovoltaic frameworks," IEEE Trans. Power Electron., vol. 21, no. 4, pp.
- [6] Trishan Esham, "Comparison of photovoltaic exhibit most extreme point following procedures", IEEE exchanges on vitality change, vol.22, No.2, June 2007.
- [7] H.Tsoukalas, "From keen framework to a vitality web: Assumption, Architecture, and Requirements" D RPT 2008, 6-9, April 2008, Nanjing china.