

A Research Paper on “A Study on Production Development And Management”

Er.Anubhav S Sharma¹, Miss Priti Rai²

¹Dept of Masters In Technology Management

²Professor, Dept of MBA

^{1,2}G.H.Raisoni College of Engineering, Nagpur, India,440016.

Abstract- *Production Development and Management is the leading management approach that companies employ to improve their product and service quality with the aim of improving typical measures of business performance (e.g. increased profits, increased market share, reduced costs and best quality). Customer requirement management entails various issues related to requirement elicitation, analysis, and specification, as well as the requirement management process. The study describes and evaluates the concepts and techniques in the development processes and the applications of an organization. We focus to examine what quality means across these organizations and to discover the differences between methodologies that do or do not apply Production Development and Management concepts. This paper offers a relationship between components, customer and supplier interactions and measures of company performance by developing a framework, which is tested and refined through a study of manufacturing company. This also explores the complex relationship between organizational context and knowledge management.*

Keywords- Production Management, profit, performance.

I. INTRODUCTION

Production is the process by which raw materials and other inputs are converted in to the finished goods. Operations management has been recognized as an important factor in a country's economic growth in service sector which become more famous. Rapid changes posed numerous opportunities and challenges. Er. Anubhav S Sharma & Prof. Priti Rai to bring new experiences and knowledge on requirement management in the production and its development. This system has major challenges in the global competitive environment. Today's effective product development is not a characterized on the creativity, but it depends on the management. This paper, review the production Management and launching to improve the productivity and represents the relationship between top down and bottom up approach to achieve goals. We refer to as requirements management, involve several disciplines and extend through all development phases. The activities which are involved in

manufacturing is called as production management. If same concept involved in services management is called as operation management.

II. LITERATURE REVIEW

WAYS OF PRODUCTION

Production by Disintegration:

By separating the contents of Crude oil or a mixture by which the desired products are produced. For example the crude oil is disintegrated into various fuel oils. Similarly salt production is also an example for.

Production by Integration:

In this type of Production various Components of the products are assembled together to get the desired product. In this process, Physical and Chemical Properties of the materials used may change. The examples are: Assembly of Two wheelers, four wheelers and so on.

Production by Service:

Here the Properties of materials (Chemical and Mechanical) are improved without any physical change. Example:-Heat Treatment of metals.

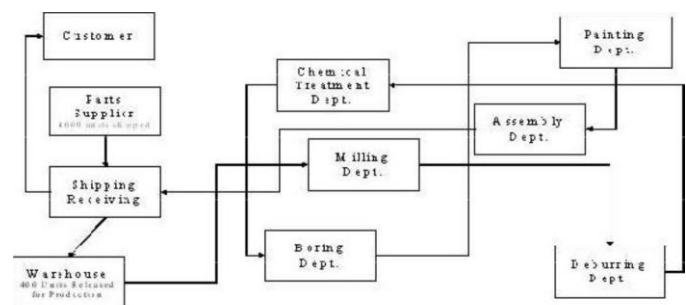

Figure: Production-Aligned ways for integration and other.

Production System:

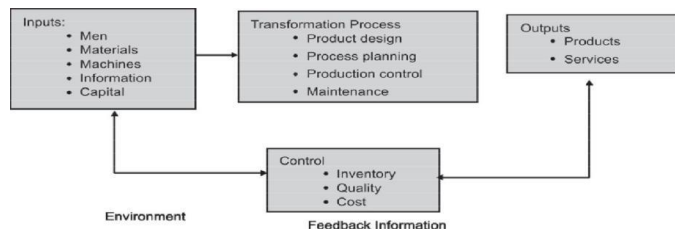

Figure 2.2: Production-Aligned Procedure of production.

Characteristic of production system :-

1. Production system has an own objective.
2. The system transforms the various inputs to useful outputs.
3. It does not operate in isolation from the other organization system.
4. There exists a procedure which control and improve system performance.

Types of production:-

1. Continuous Production
2. Batch Production.
3. Mass Production
4. Job-Shop Production.

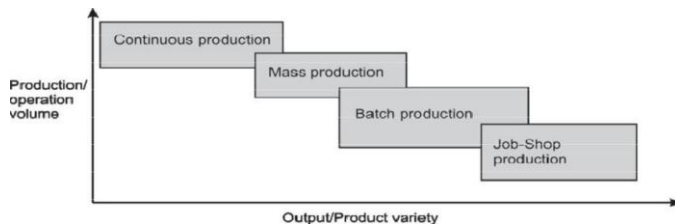

Figure:-Category-Aligned production types.

FINDING A. Example which implement it

Wegmans Food Markets

Wegmans Food Markets, is one of the premier grocery chains in the United States,.Wegmans have more than 70 stores. The company has annual sales of over Rs. 2.0 billion. It has a strong reputation for offering its customers high product quality and excellent service.

Effectiveness of processes development .It improve the productivity and represents the relationship between top down and bottom up approach to achieve goals. Therefore production development and management often include substance measurement and analysis of all the internal activity .This paper will help more organizations make the attempt .At last we concluded that management is not only a important

key but also play a vital role in before the production and after it also.

REFERENCES

- [1] Administration industrially general purveyance organization -commandment, co ordination controlee, Paris Dunned,1966
- [2] Journal of Operations Management 17 _1998. 23–37
- [3] Vocationa Business: Training, Developing and Motivating People by Richard Barrett - Business & Economics - 2003.