

CFD Analysis of Heat Transfer In A Pipe With Helix Groove

Bondili Seshu Narayana Singh¹, G. Leela Siva Rama Prasad²

¹Dept OF Mechanical Engineering

²Assistant Professor, Dept OF Mechanical Engineering

^{1,2}DJR College of Engineering and Technology , Vijayawada , A.P

Abstract- The Heat transfer through convection is mainly used in many wide range of applications the improvement of heat transfer is widely researched over the years where the heat transfer through convection in a straight pipe has been a known problem in heat and mass transfer industry. Using spirally removed groove shapes in the pipe can increase the heat transfer significantly in this project we have design and simulated different models of pipe with groove to investigate which possess the maximum heat transfer rate where the models of different pitches with groove thickness of 0.1mm and 0.2mm has been made is solid works and then simulated in Ansys Fluent with a constant heat flux. Where Numerical concepts of Computational fluid dynamics is used to evaluate results and compare between models to specify the best possible Thickness and pitch.

Keywords- Cfd , Heat transfer , grooved Pipe.

I. INTRODUCTION

Improving the heat transfer performance in heat exchanger devices, which is called heat augmentation or intensification, can play a major role in saving energy and material consumption. This also leads to reducing the manufacturing cost of heat exchanging equipment which has been used in various industrial, commercial and domestic applications. Since the vitality assets of the earth are diminishing and their expenses are expanding, plan of vitality effective heat exchangers has critical effect on vitality protection. The demand for improving heat performance leads to developing heat enhancement techniques which help in equipment size reduction, saving operating costs, and reducing pumping power in heat exchangers. Therefore, based on the purpose of the equipment, designers can focus on one of these heat enhancement criteria and provide these benefits [2] [17]. As of late, the investigation of various systems of heat move upgrade in heat exchanger gadgets has increased significant consideration and much research has been done in both heat exchange and thermodynamic thought [2] [17]. Learning about heat exchanger devices and different heat transfer techniques is the purpose of this chapter.

I (a) Heat Exchangers

Heat exchangers are extensively used in Central air frameworks (heating, ventilating and aerating and cooling), compound and power plants, refrigeration frameworks, oil plants, and so on. These gadgets give effective heat exchange between at least two liquids or strong surfaces and between liquids or strong particles with liquids at various temperatures. Heat exchangers are thermal devices, which have a major role in energy conservation and impact on climate change. They are categorized based on their transfer process, heat transfer mechanism, number of fluids, surface compactness, construction characteristics and flow arrangement. The classes of heat exchangers where the liquids are in coordinate contact for trading heat are called coordinate exchange composes, or essentially recuperators. Conversely, in other heat exchangers, there is an isolating divider amongst hot and cool liquids which are alluded to as circuitous exchange writes, or just regenerators [17]. The greater part of the heat exchangers can possibly be considered for heat improvement, be that as it may, every potential application ought to be tried to check whether the upgrade is down to earth. Nearly all heat enhancement techniques are used for heat exchangers in the refrigeration and automotive industries [26].

Heat Enhancement (Augmentation) Techniques

Augmentation procedures enable increment to heat convection in heat exchanger gadgets and reduction the warm obstruction. In numerous applications, for example, for concoction reactors, cooling and refrigeration frameworks, there are numerous procedures being examined for expanding the heat exchange rate and diminishing the size and cost of the gadgets. Studies have demonstrated that applying upgrade strategies, enhance the warm execution essentially [16]. Notwithstanding, expanding the rate of improvement is at the punishment of weight drop. Along these lines, in any heat increase plan, the heat exchange coefficient and weight drop should be dissected. These systems are ordered into 3 gatherings: uninvolved, dynamic and compound procedure [26] [16].

I (b) Passive Techniques

In these systems outside power isn't required; rather geometry or surface of the stream channel will be altered to expand heat exchange coefficients. The additions and harsh surfaces will be utilized to advance the whirl in the stream, which prompts increment in heat exchange upgrade. If there should be an occurrence of broadened surfaces, successful heat exchange zone in favor of the expanded surface will be expanded. Inactive procedures are a decent strategy because of the lower cost of set up and smaller size of the heat exchangers [16]. Heat exchange upgrade by aloof method can be accomplished by utilizing:

Coated or Treated Surfaces involve using different surface finishes and coating methods with metallic and nonmetallic material. These modifications are used for boiling and condensing applications. For example, in boiling systems, a coating layer of hydrophobic material such as PTFE (polytetrafluoroethylene) is used to promote dropwise condensation and a porous coating is used in enhancing nucleate boiling and a higher heat transfer coefficient. Sintered, multilayered and coated surfaces are among some examples of treated surfaces [26].

Rough surfaces are provided in two different methods: Integral method, where the roughness is integrated on the surfaces and made by machining or restructuring. The other is a non-integral method, which is done by placing roughness close to the surface to increase heat transfer. Both methods are generally surface modifications that increase turbulence flow, but do not increase heat transfer surface area in the field and are primarily used in a single phase flow. Also, any structure with a regular pattern that repeats and disturbs the boundary layer like a coil insert is an example of non-integral roughness [26].

Extended surfaces expand the heat transfer area which increases the heat transfer coefficient. The plain fin may just increase the area, but special structured extended surfaces can increase the heat transfer coefficient, too. In applications for gases, mostly extended surfaces are used to provide both higher heat transfer coefficient (h) and area (A). Since the heat transfer coefficient of liquids is higher than gases, shorter fin height is used for fluid application. Segmented fins on the surface cause a separation in the boundary layer. Therefore, after each separation a new boundary will be formed and will improve the heat transfer rate. These techniques are used in automotive, refrigeration systems and air conditioning applications [13].

Displaced enhancement devices are placed into a flow channel and move the fluid through the tube and displace it from the core to the surfaces with lower or higher temperatures. The objective of this technique is to increase the fluid mixing, which leads to improve energy transport. Inserts like conical ring devices, metallic mesh, disks and wire inserts are among displaced enhancement devices [26].

Swirl flow devices include different geometrical configurations which provide secondary flow and recirculation in fluids such as: helical twisted tape, inlet vortex generator, static mixer. These are creating swirls in both clockwise and counterclockwise directions. Swirl generator devices can be used in both single and multiple phase flows [26] [13].

Additives for liquids and gasses involve the addition of solid particles, soluble trace additives, gas bubbles and liquid droplets. These particles are added to the liquids or gasses to reduce the fluid resistance in the case of single phase flows. In the case of boiling systems, trace additives are added to reduce the surface tension of the liquids [26].

II. LITERATURE REVIEW

In the study by Graham, Chato and Newell (1999) [1] the performance of an axial micro fin grooved tube with helical angle of 0° for refrigerant R023a was conducted and the results compared with a similar tube with a helical angle of (18°) in different ranges of mass fluxes. The 18° helix angle tube performs better than the axially and grooved tube. Heat enhancement factors have shown 62% and 20% improvement in enhancement for helical and axially grooved tubes compared to smooth tubes at lower mass fluxes.

Bilen et al. (2009) [2] tentatively explored the impact of section geometry on heat exchange and grating attributes of completely created turbulent stream in notched tubes (roundabout, trapezoidal and rectangular). Greatest heat exchange improvement is gotten up to 63% for roundabout furrow, 58% for trapezoidal score and 47% for rectangular depression, contrasted with smooth tubes. Likewise, the relationship condition is created tentatively for Nusselt number and grinding factor for each tube. In the scope of Reynolds between 10000 to 38000 warm execution (η) for every single scored pipe is in the scope of 1.24-1.28 for roundabout notch, 1.22– 1.25 for trapezoidal furrow and 1.13– 1.26 for rectangular depression at steady pumping power.

Bharadwaj, Khondge and Date (2009) [3] experimentally investigated the compound method of heat enhancement with a constant wall heat flux for water flow in the internal spiral grooved tube with twisted tape. Different

twist ratio ($Y = 10.15, 7.95$ and 3.4) is considered for this study, then pressure drop and heat transfer characteristics are defined. Heat transfer enhancement yields 400% in laminar flow and 140% in turbulent flow for spirally grooved tubes without twisted tape compared with smooth tubes. Adding a twisted tape to a spirally grooved tube, increases the enhancement to 600% for laminar and 140% for turbulent flow. However, in both cases, the reduction in heat enhancement observed is $2000 < Re < 13000$. Among all twisted ratios, the twisted ratio of $Y = 7.95$ has the highest heat transfer performance in both laminar and turbulent flows.

Xinyi and Zhou (2012) [4] investigated an overall heat transfer performance and friction factor of water flow in an enhanced surface rectangular channel both experimentally and numerically. Discontinuous crossed ribs and rib-grooves provided in tubes and the flows were examined in a turbulent region. CFD Nusselt number and friction factor are 10% - 13.6% higher for ribbed-grooved channel in comparison to experimental data. Furthermore, the effect of rib angles on the heat transfer characteristics was studied by Fluent software. The simulation results showed a rib angle of 45° has the best overall thermal performance, about 18%-36% higher than a rib angle of 0.

Kaji, Yoshioka and Fujino (2012) [5] experimentally investigated the heat transfer performance of smooth and internally grooved tubes in an air-cooled heat exchanger using CO₂ as a refrigerant and Poly alkyl glycol (PAG) oil flow as a lubricant in both cooling and evaporating heat exchanger systems. Two internal grooved configurations (Herringbone and spiral) are examined for this study. The heat transfer coefficients which are obtained experimentally are 1.8 and 2.1 higher than smooth tube for the spiral and herringbone tubes respectively.

Heat transfer performance can be improved by using inner grooved tubes with suitable patterns. Also, the oil's effect was investigated by using an instrument to visualize flow inside the tube. It was observed that herring bone groove has better performance in comparison to spiral and smooth tube in the presence of oil. Therefore, inside geometry can affect oil's behavior.

Heat augmentation of internally enhanced surfaces particularly roughness became quite important since the method is economically beneficial for commercial applications. In refrigeration industries mostly rough surfaces are used on the water side of evaporators and condensers in large equipment. Also studies showed that roughness is used in gas turbine blade and gas-cooled nuclear reactors. There are many different geometries that are used for heat enhancement

which was explained in this chapter. Some important key factors which should be considered in design and investigation of different roughness including grooves are as follows: roughness height (e), spacing or pitch size (p), roughness width (w) and geometry shape of the roughness. Also two other factors in groove are applied such as helix angle and number of starts. The integral helical groove may be made as single or multi-start elements. Studies showed that the greatest material saving is for helical internal groove which is about 12% greater than axial grooves. Furthermore, most studies have been conducted on multiple start groove tube, and even Turbo chill tube has commercially made these tubes for different applications. Based on experimental study that was chosen to compare with the CFD results, the heat transfer enhancement in internally grooved tubes was conducted for Reynold in the transient region while fully turbulent. Recently, CFD simulations are used to validate experimental studies. The CFD modeling technique has been recognized as a powerful and effective tool to gain better understanding of the complex heat transfer and fluid problems. Furthermore, due to good agreement between CFD simulation results and experimental studies, scientist could save a great amount of time and money by using simulation techniques to predict the heat transfer characteristics of a flow in heat augmentation methods. Based on this review, many experimental works can be simulated and analyzed by CFD software. In the current study the CFD software STARCCM+ is used to study the heat transfer performance of internally grooved tubes with different pitch sizes in turbulent flow.

Aroonrat et al. (2013) [6] tentatively explored the impact of contribute measure inside helical notched tubes on heat exchange and stream qualities in treated steel tubes. The impact of the scores has demonstrated that the Nusselt number and grating component got from the helical furrowed tubes were higher than those of the smooth tubes. In addition, the Nusselt number and grinding factor expanded with the diminishing of the pitch estimate. Generally, Thermal execution has enhanced for the inside furrowed tubes.

Rahman, Zhen and Kadir (2013) [7] carried out a CFD analysis of flow of refrigerant (R22) through internal grooved copper tubes with Fluent software and investigated heat transfer enhancement in the tubes. Experimental study is too costly and takes a longer time in gathering necessary information. Therefore, numerical simulation is conducted instead of experimental research. The geometry model of an inner grooved tube was designed with SolidWorks software and the grid was generated with GAMBIT software. Then the model was imported to Fluent software to set up the boundary condition and solve the simulation model. The results were obtained and compared with published experimental results.

Refrigerant (R22) was used as fluid through a copper tube for two different purposes: condensation and evaporation. The heat transfer coefficient improved for enhanced tube in comparison with smooth tube. The CFD results and experimental data showed strong agreement in this study. In Salman et al. (2013) a study of quadrant cut twisted tape (QCT) inserts were used as a swirl generator inside the tube, then heat transfer and friction factor characteristics were investigated. They used Sieder and Tate correlation to validate their data for smooth tube. The results for uncertainty for the Nusselt and Friction factor were determined to be around 8% and 10%, respectively. Results were in the range of Reynolds of 0-2000. The Nusselt number increased with an increasing Reynolds number. The (QCT) inserts by generating vortices and disrupting the boundary layer, improved the fluid mixing and respectively the heat enhancement.

Salman et al. (2014) [8] used Computational Fluid Dynamics (CFD) to investigate heat transfer characteristics and friction factors in a circular tube fitted with twisted tape inserts in a laminar flow region at constant heat flux. Fluent software is used to simulate plain tube and a tube with twisted tape inserts with different twist ratios ($\gamma = 2.93, 3.91, 4.89$) and alternative angles ($\beta = 30^\circ, 60^\circ, 90^\circ$) (Fig 2.4). The results are validated with theoretical and experimental work in literature. Therefore, CFD Simulation is a reliable method for investigating the heat augmentation. Tubes with different twist ratios and angles of helix have shown higher value for The Nusselt number and friction factor compared to plain tubes and tubes equipped with plain twisted tapes. In this study, the highest heat transfer enhancement belongs to the alternate axis $\beta = 90^\circ$ and twisted tape ratio of ($\gamma = 2.93$).

Liu, Xie and Simon (2015) [9] studied the heat transfer performance of turbulent flow (Re: 10,000-25,000) in square duct with cylindrical groove. The purpose of this study is to find out the desirable design for better enhancement rate and minimum pressure drop penalties. In this study, 4 different cylindrical shaped grooves in a square rib groove tube were considered and the results were computed with CFD modeling. The pressure drop is less for cylindrical shaped groove tubes in comparison to the square rib tube. The rounder the edges of the cylindrical groove, the better total heat enhancement.

III. CFD MODELLING

Most flows on earth and around us are in a turbulent region, similarly, so are the turbulent flows inside a cylindrical tube of a combustion engine. These flows have different mechanisms which are categorized by a dimensionless factor called Reynolds number. To describe and predict the

characteristics of flow is difficult particularly for turbulent flows. There are three approaches to obtain the solution of fluid flow and heat transfer problems:

- Theoretical approach
- Experimental approach
- Numerical approach, Computational Fluid Dynamics (CFD)

III (a) Theoretical Methods

This method has the advantage of providing an exact result by solving the governing equations of flow. However, this method is limited to a few classes of problems since the analytical solution for 3D and 2D flows are highly complex to solve.

Governing Equations

There are three fundamental laws describing fluid flow, heat transfer and mass transfer. The governing equations of flow are simply a version of conservation laws of physics and may be described by both integral and partial differential equations.

The governing equations can be presented in Cartesian, cylindrical and spherical coordinates. In this study, the conservation laws are expressed in Cartesian coordinates as follows:

Conservation of Mass

Mass flow that is entering the control volume ($dx dy dz$) should be equal to the mass flow that is leaving the control volume.

$$\frac{D\rho}{Dt} + \rho \nabla \cdot \vec{V} = 0$$

Conservation of Mass (1)

Conservation of Momentum (Navier-Stokes Equations)

Conservation of momentum or Navier-Stokes equations consists of 3 equations in each direction. These equations are generated based on Newton's second law of motion which stated the momentum of an object is proportional to the net force that is acting on it in the same direction. The net force includes: body forces such as gravity and surface forces that acts on the surface of the element. The three equations in cylindrical coordinates by assuming Newtonian fluid with constant density, viscosity are as follows:

$$\rho \left(\frac{\partial u}{\partial t} + u \frac{\partial u}{\partial x} + v \frac{\partial u}{\partial y} + w \frac{\partial u}{\partial z} \right) = \rho g_x - \frac{\partial p}{\partial x} + \mu \left[\frac{\partial^2 u}{\partial x^2} + \frac{\partial^2 u}{\partial y^2} + \frac{\partial^2 u}{\partial z^2} \right]$$

(x direction) (2)

$$\rho \left(\frac{\partial v}{\partial t} + u \frac{\partial v}{\partial x} + v \frac{\partial v}{\partial y} + w \frac{\partial v}{\partial z} \right) = \rho g_y - \frac{\partial p}{\partial y} + \mu \left[\frac{\partial^2 v}{\partial x^2} + \frac{\partial^2 v}{\partial y^2} + \frac{\partial^2 v}{\partial z^2} \right]$$

(y direction) (3)

$$\rho \left(\frac{\partial w}{\partial t} + u \frac{\partial w}{\partial x} + v \frac{\partial w}{\partial y} + w \frac{\partial w}{\partial z} \right) = \rho g_z - \frac{\partial p}{\partial z} + \mu \left[\frac{\partial^2 w}{\partial x^2} + \frac{\partial^2 w}{\partial y^2} + \frac{\partial^2 w}{\partial z^2} \right]$$

(z direction) (4)

where:

ρ : Fluid density

g_x, g_y, g_z : Body forces

μ : Fluid viscosity

P : Static Pressure

t : time

III (b) 3D models Created for the Simulation.

The 3d Cad package used for designing the grooved pipe is solidworks the proprietary software of Dassault systems lets us create and convert the solid models in any format feasible for this project to analyse the heat and flow through the grooved pipe at different pitches and groove area total of eight models is required with the groove pitches of 130mm 205mm 254mm 305mm. of the spiral groove for the pipe dia of 7.1 mm and 2000mm length below are the pictures of the different cases cad models later the Flow simulation is done using fluent 18 package .

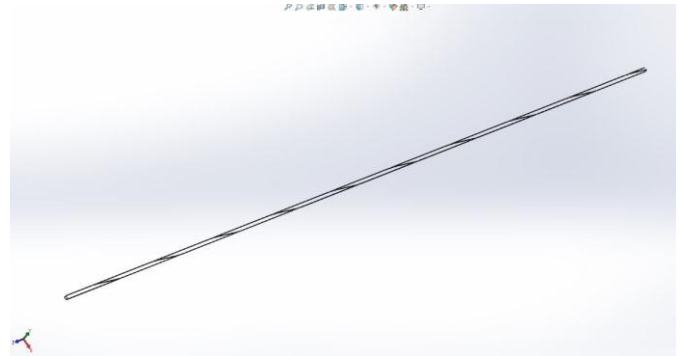

Figure 2 Pipe with Groove 0.1mm and pitch 205mm

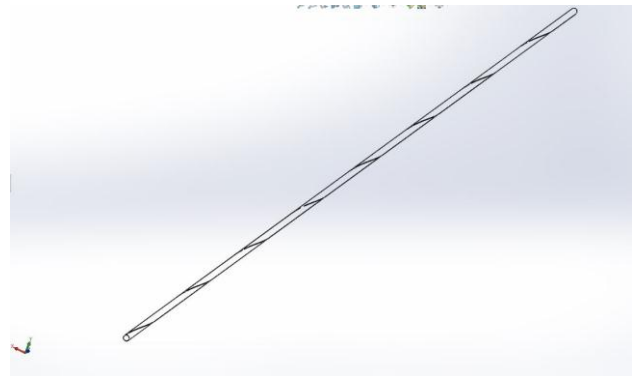

Figure 3 Pipe with Groove 0.1mm and pitch 254mm

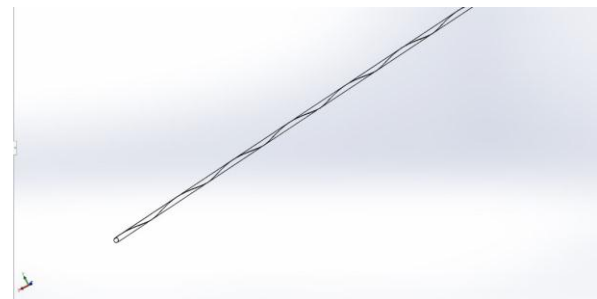

Figure 4 Pipe with Groove 0.1mm and pitch 305 mm

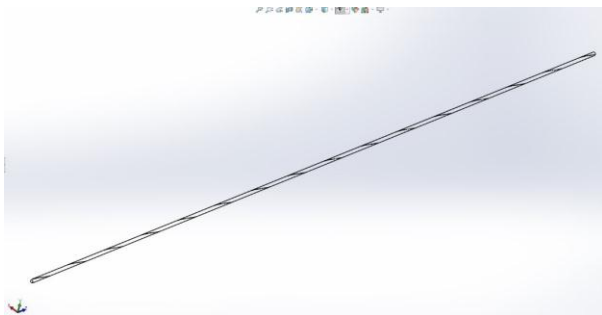

Figure 1 Pipe with Groove 0.1mm and pitch 130mm

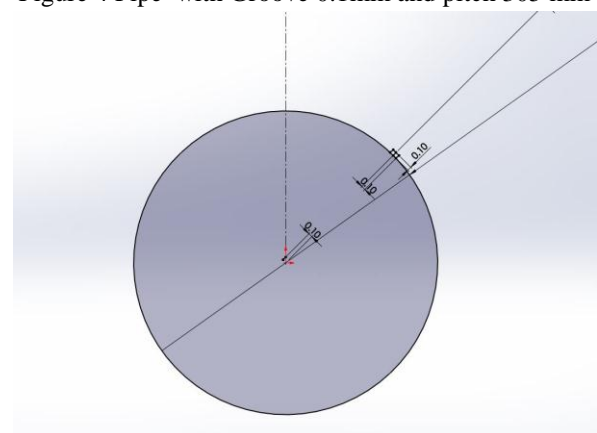

Figure 5 Pipe with Groove 0.1mm

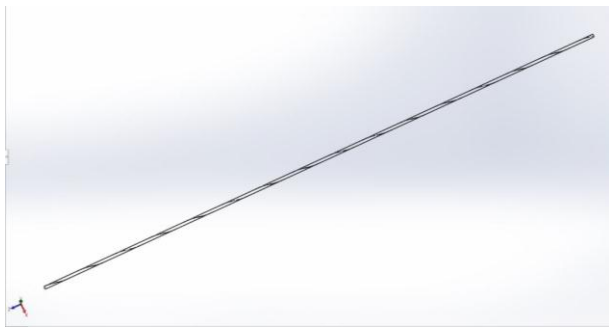

Figure 6 Pipe with Groove 0.2mm and pitch 130mm

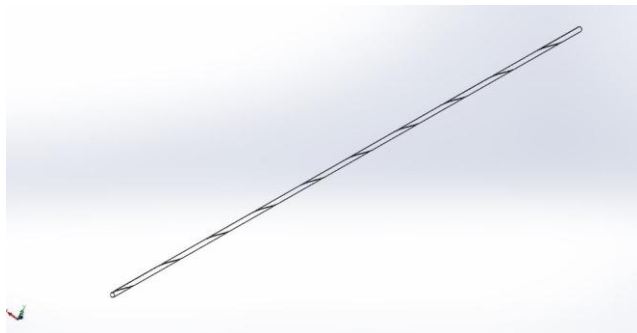

Figure 7 Pipe with Groove 0.1mm and pitch 205mm

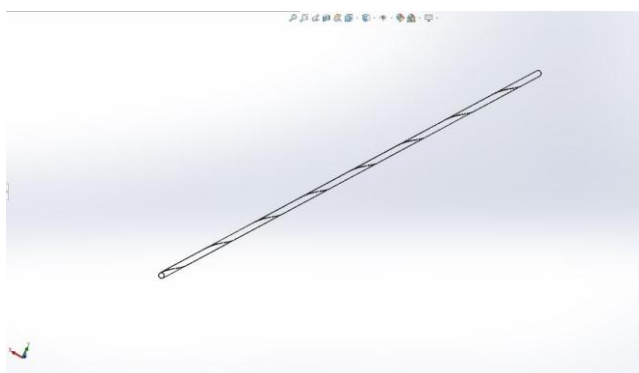

Figure 8 Pipe with Groove 0.1mm and pitch 254mm

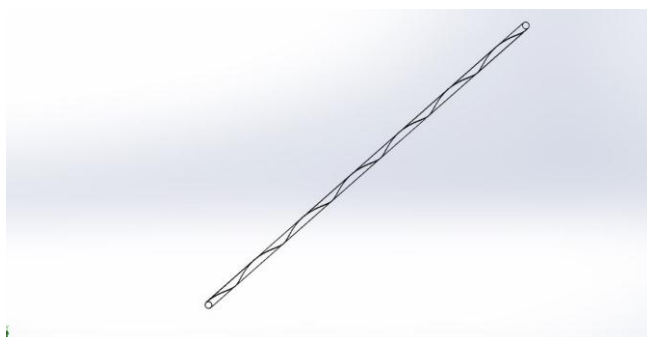

Figure 9 Pipe with Groove 0.1mm and pitch 305mm

IV. CFD MODEL DESCRIPTION

IV (a) Description of Geometry Model

Geometry model of the CFD simulation can be designed either by the Computational aid design (CAD) tools which are built in the FLUENT 18.0 CFD package or imported from another CAD design software into the CFD software for further analysis. In this project, all models were generated in SolidWorks which is a CAD software for designing solid models. Geometry starts with a 2D sketch which is defined by numeric and geometric parameters. Then, the tube is extruded from the 2D model and becomes a 3D part. The groove is cut swiped from the inside of the tube in a helical pattern. With this software, parts and assemblies can be created for both simple and complex geometry purposes. Figure 4.1 and 4.2 depict the 2D and 3D sketches of the grooved tube. Test tubes include four horizontal cylindrical tubes with internal helical grooves and, also, another three helical grooved tubes for comparison with the experimental study. The detail of the each test section is provided in table 4.1. Tubes are made of stainless steel with inner diameter 7.1 mm, outer diameter 9.5 mm and length of 2000mm.

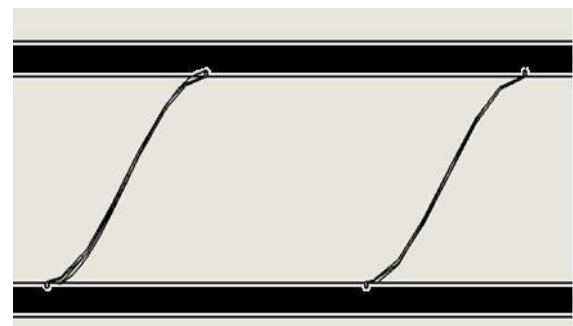

Figure 10 2D Sketch of a Groove Tube

Table 1. The Details of the Test Sections

Tube	Groove Width (w)	Groove Depth (e)	d_i (mm)	Pitch Length (mm)	Length (mm)
GT 130	0.2	0.2	7.1	130	2000
GT 203	0.2	0.2	7.1	203	2000
GT 254	0.2	0.2	7.1	254	2000
GT 305	0.2	0.2	7.1	305	2000

IV (b). Meshing Scheme

Grid generation is an important aspect of any CFD modeling; therefore, in order to have an accurate simulation of flow and heat transfer, the geometry models should have good

quality meshes. In the finite volume method, the geometry model is discretized to a number of small elements which are called cells by partial differential equation and algebraic methods. Then, the integral form of the conservation equations is applied to the cells to get the discrete equations for them [5]. Precise meshes are needed to capture the complexity of the flow characteristics and geometry from near the wall to the bulk of the fluid. FLUENT 18.0 provides several meshing strategies that are suitable for different applications [25]. Before starting the simulation, the best mesh should be picked for the model. For this purpose, the mesh generation for a geometry model is started with coarse meshes and then the mesh sizes will be refined. The results will be analyzed until slight changes are observed in them. This is called mesh-independent study in CFD modeling. The CFD results are highly dependent on the mesh such as cell size, shape and grid density and including stretching ratios between cells and skewness angles, etc.

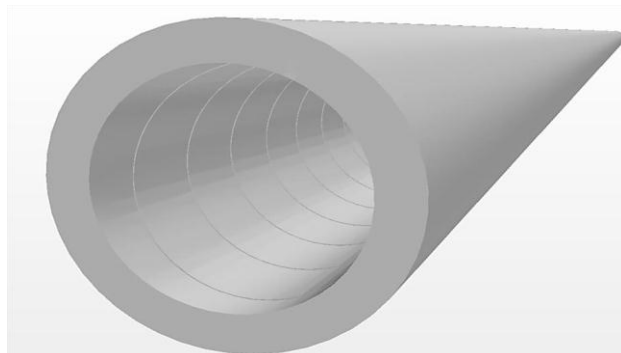
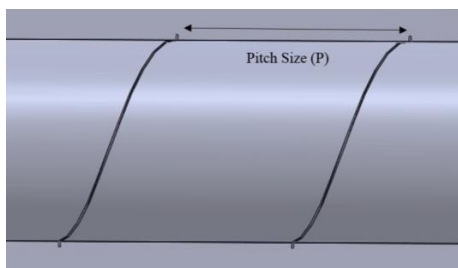
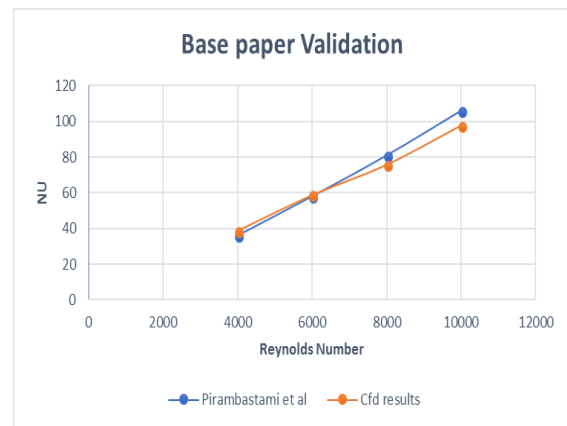

Figure 11 Schematic Diagram of the Grooved Tube

Validation With The base paper.

A smooth tube and helically furrowed tube models with pitch lengths of , 254 mm, taken from the exploratory work , were considered for approval of the present reproduction. Comparative limit conditions were utilized as a part of the present CFD work, as gave in the exploratory tests . The Nusselt (Nu) number is tackled utilizing the Cfd and Below is the Results



V. RESULTS AND DISCUSSIONS

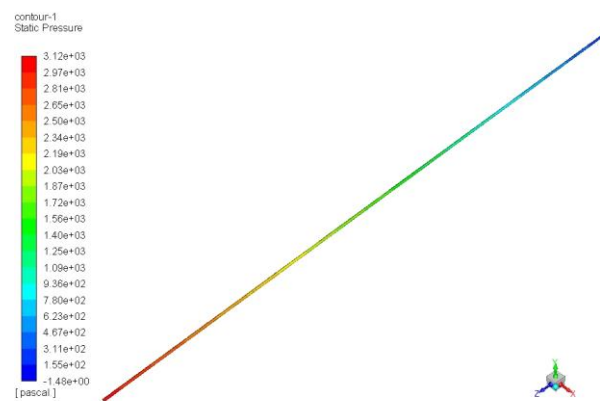

Figure 12 Pressure Contour of the Grooved pipe with 250mm pitch at 0.2 groove Thickness.

The above fig Shows the pressure distribution at the inlet end of the pipe and low at the outlet end of the pipe the observation from the figure represents that the pressure is decreasing from inlet to out let because of the axial velocity in the grooved tube with 250 mm pitch between helical turns and the width of the groove would be 0.2mm. Left hand side of the figure represents the legend where the red color is the maximum pressure and the blue color is the min pressure it eases the certainty of the readings in the above picture.

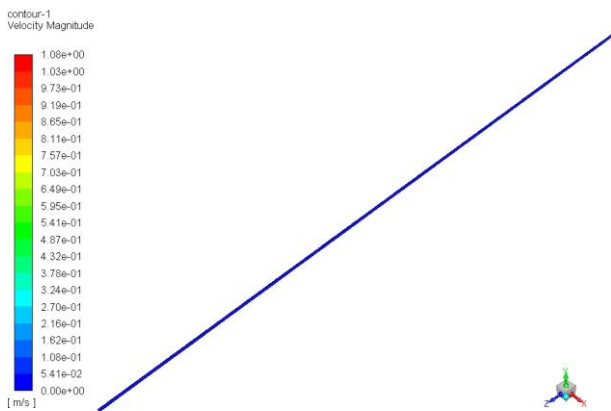

Figure 13 Velocity Contour of the Grooved pipe with 250mm pitch at 0.2 groove Thickness.

The above fig Shows the Velocity distribution at the inlet end of the pipe and low at the outlet end of the pipe the observation from the figure represents that the Velocity of 1.08 m/s is increasing from inlet to outlet because of the axial velocity in the grooved with 250 mm pitch between helical turns and the width of the groove would be 0.2 mm. Left hand side of the figure represents the legend where the red color is the maximum velocity and the blue color is the min velocity it eases the certainty of the readings in the above picture.

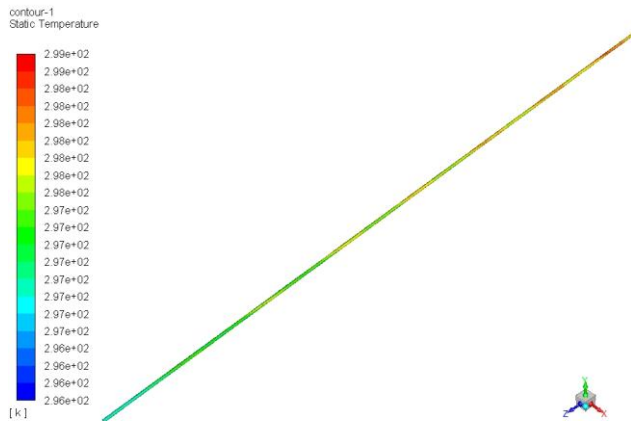

Figure 14 Temperature Contour of the Grooved pipe with 250mm pitch at 0.2 groove Thickness.

The above fig Shows the Temperature distribution of the grooved tube the observation from the figure represents that the Temperature of 299.09K is in the Groove with the constant heat flux given with 250 mm pitch between helical turns and the width of the groove would be 0.2mm. Left hand side of the figure represents the legend where the red color is the maximum Temperature and the blue color is the min Temperature it eases the certainty of the readings in the above

picture. most amount of temperature is occurring 299.09 K at groove.

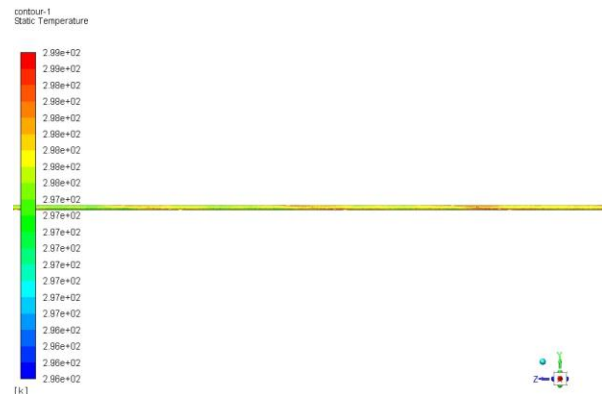

Figure 15 Temperature Contour of the Grooved pipe with 250mm pitch at 0.2 groove Thickness.

The above fig Shows the Temperature distribution of the grooved tube the observation from the figure represents that the Temperature of 299.09K is in the Groove with the constant heat flux given with 250 mm pitch between helical turns and the width of the groove would be 0.2mm. Left hand side of the figure represents the legend where the red color is the maximum Temperature and the blue color is the min Temperature it eases the certainty of the readings in the above picture. most amount of temperature is occurring 299.09 K at groove.

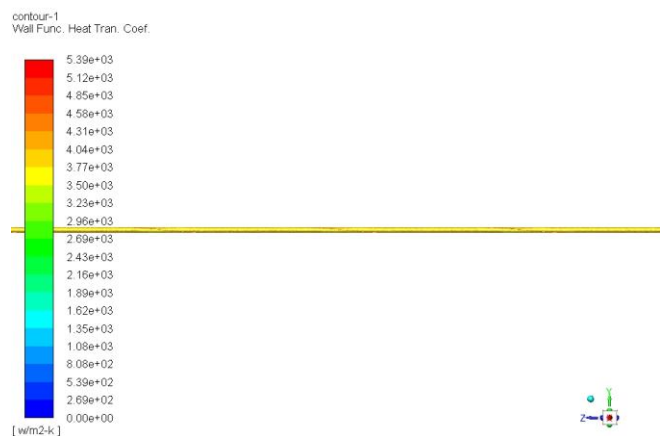
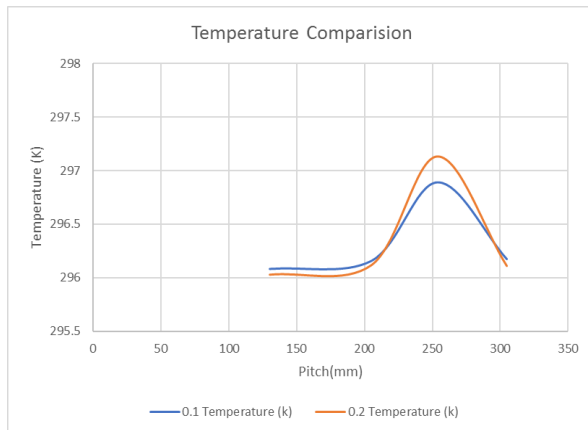

Figure 16 Heat transfer Coefficient Contour of the Grooved pipe with 250mm pitch at 0.2 groove Thickness.

VI. CONCLUSION

From the simulation done in Fluent 18 with water The Spiral Groove with 0.1mm and 0.2mm thickness with different pitches at 130mm, 205mm, 250mm &350mm the out

let temperatures for all the cases is extracted and plotted the relatively high temperature is observed at 0.2mm with 250mm pitch at the tube dia of 7.1mm



REFERENCES

- [1] Graham, D., Chato, J.C., Newell, T.A., (1999), *IJHMT*, Issue 42, Page number 1935-1944.
- [2] Bilen, K., Cetin, M., Gul, H., Balta, T., (2009), *ATE*, Issue 29, Page number 753–761.
- [3] Bharadwaj, P., Khondge, A.D., Date, A.W., (2009), Heat transfer and pressure drop in a spirally grooved
- [4] Xinyi, T & Dongsheng, Z., (2012), *Chinese JCE*, Issue 20(2), Page number 220-230.
- [5] Kaji, R., Yoshioka, S., Fujino, H., (2012) The Effect of Inner Grooved Tubes on the Heat Transfer Performance of Air-Cooled Heat Exchangers of Co2 Heat Pump System at International Refrigeration and Air Conditioning Conference, Purdue e-Pubs. .
- [6] Aroonrat, k., Jumholkul, C., Leelaprachakul, R., Dalkilic. A.S., Mahian, O., & Wongwises, S., 2013, , *ICHMT*, ISSUE 42, pg no 62–68.
- [7] Rahman, M., Zhen & Kadir A.K., (2013), 4th ICEE, IOP Publishing Ltd.
- [8] Salman, S.D., Kadhum, A.A.H., Takriff, M.S., Mohamad, A.B, (2013), *Mathematical Problems in Engineering*, Hindawi Publishing Corporation.
- [9] Liu, J., Xie, G. & Simon, T.W., (2015), *IJHMT*, Issue 81, pg no 563–577.
- [10] Blazek, J., 2001, computational fluid Dynamics: principle and applications, Alstom power Ltd, Switzerland, Elsevier.
- [11] Ceylan, K., Kelbaliyev, G., (2003), *ATE*, Issue 23, pg no 557–570.
- [12] Chaurette, J. PIPE ROUGHNESS VALUES, (2003, February) Retrieved from www.lightmypump.com February 2003
- [13] Eiamsa-ard, S., Promvonge, P., (2008), *ICHMT*, Issue 35, pg no 844-852.
- [14] Jiji, L.M. (2009). *Heat Convection* (2nd ed.). Germany: Springer.
- [15] FLUENT 18.0 user manual, version 9.04.009. CD-Adapco.
- [16] Georgi Kalitzin, G., Medic, G., Iaccarino, G., Durbin, P., (2005), *JCP*, ISSUE 204, pg no 265–291.
- [17] Webb, R.L. & Kim, N.H., (2005), Principles of Enhanced Heat Transfer (2nd ed.), New York: Taylor & Francis.
- [18] San, J. Y. & Huang, W.C., (2006), *IJHMT*, Issue 49, pg no 2965–2971.
- [19] Elyyan, M.A. (2008). Heat Transfer Augmentation Surfaces Using Modified Dimples/Protrusions (Dissertation). Virginia Polytechnic Institute and State University, Virginia.
- [20] Oliver, J.A. (2009), dissertation, university of Pretoria, South Africa.
- [21] Zikanov, O. (2010). *Essential Computational Fluid Dynamics* (1st ed.). New Jersey: John Wiley & Sons.
- [22] Johar, G. & Hasda, V., (2010) Thesis, Department of Chemical Engineering, National Institute of Technology Rourkela.
- [23] Liu, S. & Sakr, M., (2013) *RSER*, Issue 19, Page number 64–81.
- [24] Manjunath, K. & Kaushik, S.C., (2014), Second law thermodynamic study of heat exchangers: A review, *RSER*, 40, 348–374.
- [25] Salman, S. D., Kadhum, A.A.H., Takriff, M.S., Mohamad, A.B., (2014), , *Heat Transfer—Asian Research*, 43, 4.
- [26] Al-Shamani, A.N., Sopian K., Mohammed, H.A., Mat, S., Ruslan, M.H. & Abed. A.M, (2015), Enhancement heat transfer characteristics in the channel with Trapezoidal rib-groove using nano fluids, *Case Studies in Thermal Engineering*, 5, 48–58
- [27] Singh, S., Singh, B., Hans, V.S., Gill, R.S. (2015), CFD (computational fluid dynamics) investigation on Nusselt number and friction factor of solar air heater duct roughened with nonuniform cross-section transverse rib, *Journal of Energy*, 84, 509-517.