

Utility Applications by Pulse Solar Converter (R12SC)

S.Munilokaiah¹, Puttur M.Lokanadham²

¹Dept of EEE

²Assistant Professor, Dept of EEE

^{1,2}SVP CET

Abstract- This paper presents a reconfigurable 12 – pulse solar converter (R12SC) for utility-scale photovoltaic (PV) battery applications. The main concept is to use the 12-pulse, 3-ph, 3-winding; star-delta transformer based solar PV converter system, integrated with battery storage, to perform dc/ac and dc/dc operations. This converter solution is appealing for utility applications as it provides the optimization between costly multi-stage converters but with low harmonic performance characteristics and non-costly single-stage converters but with high harmonics. In this paper, a combination of analysis and the performance characteristics of R12SC during normal steady state ac/dc and dc/ac operations, verified with MATLAB software, are presented. Also, the analysis of R12SC support, in STATCOM operation mode, to the ac grid during the ac grid fault scenarios is presented in this paper.

Keywords- 12 pulse converter, battery, concentrating solar power (CSP), converter transformer, dc/ac operation, energy storage, MATLAB, maximum power point tracking (MPPT), photovoltaic (PV), power transformer, proportional integral control (PI control), solar, STATCOM.

I. INTRODUCTION

The continued growth of electrical energy consumption demands many alternatives such as efficient production, distribution and utilization of electrical energy of conventional technologies along with the renewable energy sourced electrical power generation. Of many options available, solar power generation is one of the emerging renewable energy source technologies, as the sunlight is Earth's most abundant source of energy.

The commercially available solar energy technologies are concentrating solar power (CSP) generation and the solar photovoltaic (PV) power generation. The CSP technology uses mirrors or lenses to focus sunlight onto a receiver, which contains working fluid. This fluid transfers the thermal energy to a heat engine that drives an electrical generator.

The solar PV technology uses crystalline silicon PV cells, which are made up of semiconductor materials. PV cells

convert solar energy into electrical energy by enabling solar photons to excite from their ground state, producing a free “electron: and “hole” pair. The “electron” and the “hole” are then separated by an electric field and pulled towards positive and negative electrodes, generating electrical energy [3].

The solar PV technology is widely accepted technology, as it converts sunlight directly into electrical energy and is integrated with great benefits to economy, politics and society such as improvement in the ecological environment, increased utilization of green renewable energy etc.

This paper introduces a novel reconfigurable 12-pulse solar converter (R12SC). The basic concept is to use 12-pulse power conversion system, integrated with battery storage, to perform different operations related to the solar PV utility applications.

Section II introduces the proposed R12SC circuit, different operation modes and system benefits. Section III presents the control techniques. Section IV presents the simulation results, which demonstrates the attractive performance characteristics. Section V summarizes and concludes the paper.

II. R12SC

A. Schematic diagram and design considerations

Integration of solar energy with power grid consists of the following two critical challenges.

- i. Non continuous energy supply, due to the seasonal and periodic variations [5].
- ii. Power quality problems such as voltage fluctuation, voltage distortion, harmonics etc.

The impacts of non-continuous energy supply can be minimized by integrating the energy storage devices such as batteries, fuel cells and by including the advanced power electronic based dc/ac and ac/dc conversion technologies. The impacts of power quality problems can be minimized by multi-stage converters, which intern leads to additional

challenges such as high cost, complex control, less efficiency and bulky . The proposed R12SC achieves the cost optimization between the costly multi-stage converters but with low harmonic generation and non-costly 6-pulse converters but with harmonics.

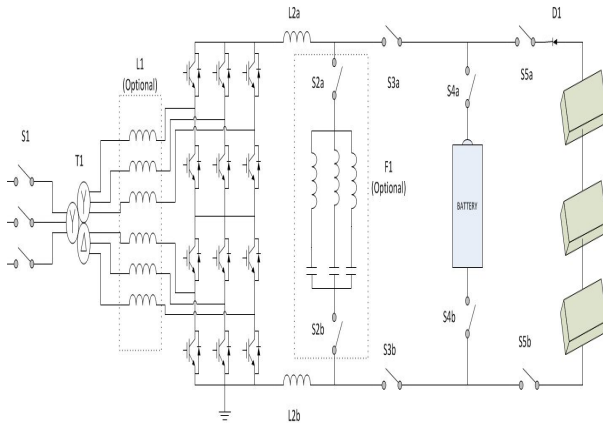

Figure 1: Schematic diagram of the proposed R12SC Circuit

The schematic diagram of the proposed R12SC is presented in Figure 1. The major equipment / systems are converter transformer (T1), optional ac reactor (L1), 12-pulse converters, dc reactor (L2), optional filter bank (F1), Battery and the PV cells. The basic concept of

1. Selecting 3-ph, 3-winding star-delta converter transformer (T1) is to provide phase displacement between the two ac supplies and 5th and 7th harmonics at source before conversion.
2. Arranging secondary side star of T1 on high voltage side and delta winding of T1 on low voltage side reduces the insulation cost.
3. Including the optional ac reactor (L1) enhances the usability of readily available standard power transformers, than that of the converter transformers. This reduces the engineering design complexities and enables the wide range of opportunities while selecting the transformer T1 supplier.
4. Selecting the dc reactor (L2) reduces the harmonic currents and improves the dynamic stability of the system by reducing the rate of current increase during fault conditions.
5. Including the optional filter bank (F1), enhances the power quality and eliminates the higher order harmonics and hence no disturbances will be introduced in the nearby telephone lines.
6. Selecting the battery provides intermediate active power support during the non-continuous energy supply from the solar PV-cells and enables the STATCOM operation mode.

All these concepts are very much suitable for utility-scale solar PV applications.

B. Operation modes

All the possible operation modes for the R12SC are presented in Table 1.

Table 1: Operation modes

Mode	Name	Conversion
1	PV to grid	dc to ac
2	Grid to battery	ac to dc
3	Battery to grid	dc to ac
4	Battery and PV to grid	dc to ac
5	STATCOM	dc to ac

1. In mode 1, the PV is directly connected to the ac grid through a dc/ac operation of the converter with possibility of maximum power point tracking (MPPT) control. The switches S4a and S4b are remain open and all other switches are closed.
2. In mode 2, the battery is directly charged from the ac grid. The switches S5a and S5b remain open and all other switches are closed.
3. In mode 3, the battery will be discharged and the exports the available power to the grid. The switches S5a and S5b remain open and all other switches are closed.
4. In mode 4, both the PV and battery provide the power to the grid. All the switches are closed. In this mode, the dc voltage is same as that of the PV voltage and is enforced by the battery voltage; hence MPPT control is not possible.
5. In mode 5 (STATCOM), the power plant operates as pure reactive power exchange unit with the ac grid. In this mode, no active power exchange with the ac grid will be required and much beneficial during non-sunny periods such as night times and winter seasons. This operation mode will be helpful in controlling unbalanced ac networks, for instance in the presence of large single-phase loads.

C. Advantages of R12SC concept

The R12SC concept provides significant advantages, to the utility-scale solar PV power plant owners, in terms of system planning and active/reactive power export / import. The current state-of-the-art technology is to integrate the energy storage into the ac side of the solar PV system. Hence the non-continuous power supply impacts will be minimized. The R12SC concept allows not only the system owners to

possess an expandable asset that helps them to plan and operate the power plant but also manufacturers to offers a cost-competitive decentralized PV energy storage solution, without compromising the power quality. The technical and financial benefits that the R12SC solution is able to provide are more apparent in larger solar PV power plants. For example:

- i A large solar PV power plant using the R12SCs can be controlled more effectively and its power can be dispatched more economically because of the operation flexibility.

A. R12SC control

The ac/dc operation is utilized for STATCOM operation mode and to charge the battery from the grid. The dc/ac operation is utilized for delivering the power to the grid from PV, Battery or both. The MPPT algorithm is used to deliver the maximum power to the grid from PV. The R12SC control is designed with the concepts of synchronous reference frame and proportional integral control (PI control). The overall block diagram is presented in the Figure 2. In a reference frame rotating synchronously with the fundamental excitation signals are transformed into dc signals. The dc/ac operation with battery and PV (mode 4), the R12SC control should co-ordinated with the battery management system (BMS), which is not shown in the Figure 2.

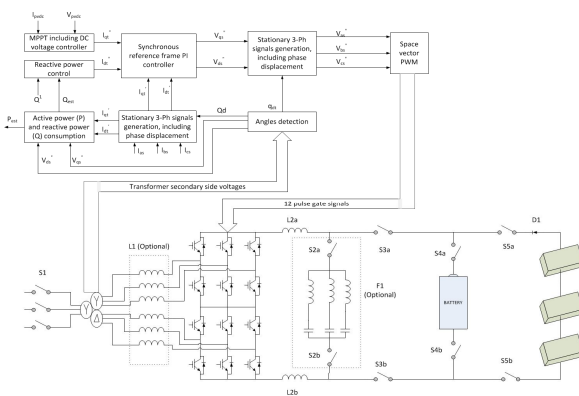

Figure 2: Control block diagram of R12SC circuit

B. Design considerations

The main salient feature of the project is to propose a new solution with minimal complexity, lowest cost, reduced harmonics, minimum modifications and suitability for broad range of customers.

The phase shifting power transformer supplies the AC voltages in two separate circuits with a relative phase shift of 30° and consequently 5^{th} and 7^{th} order harmonics will be

eliminated. The arrangement of power transformer secondary star winding connection to the upper 6-pulse bridge and the delta winding connection to the lower 6-pulse bridge minimizes the insulation levels requirement and reduces the cost of insulation.

The optional ac side reactors (L1) will simplify the design concept by providing the readily available standard power transformers selection; else the power transformer project specific customization will be required. The optional dc side filter banks providing the flexibility for specific customer needs with highest power quality requirements; else the same can be eliminated to minimize the cost.

III. SIMULATION RESULTS

The block diagram presented in **Figure 2** and the corresponding control algorithms, to verify the R12SC concept, are implemented in with MATLAB / SIMULINK. The performance characteristics of the R12SC in different operation modes are tested extensively, with the different practical parameters including the grid synchronization, power factor control, MPPT control etc. However, the STATCOM operation mode, performance improvements with DC filter (F1) and performance deviations without the series reactors (L1) are not simulated, as these concepts are out of the current R12SC scope.

A. Performance Investigation of the dc/ac and ac/dc operation modes

The R12SC configuration can be operated in any of the operation modes presented in Table 1. In the utility applications of the active power transfer between the solar power plant and the ac grid, the operation mode 4: Battery and PV to grid is more suitable. Hence, the simulation results of mode 4 are presented. These simulation results validate the satisfactory performances.

For mode 4, the PV voltage at solar array, DC voltage of the 12 pulse converter, battery voltage, ac grid current and the ac grid voltage are presented in the below Figure 3 to Figure 6 respectively. A few observations of the simulation results are

- After reaching a peak value, the PV voltage remains at a steady state value
- After reaching a peak value, 12 pulse converter dc output voltage remains at a steady state value
- After reaching a peak value, the battery voltage remains at a steady state value

- The ac grid voltage increases to a maximum value, and then starts decreasing.
- The ac grid current increases to a maximum value, and then starts decreasing.

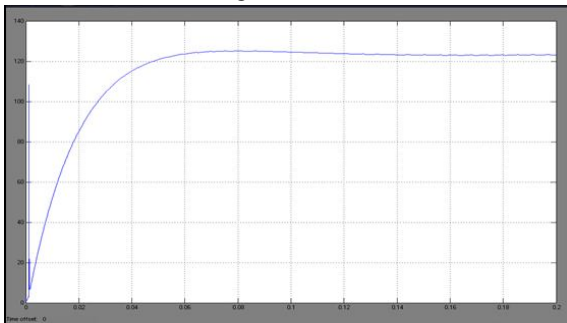

Figure 3: Mode 4 simulation results – PV voltage

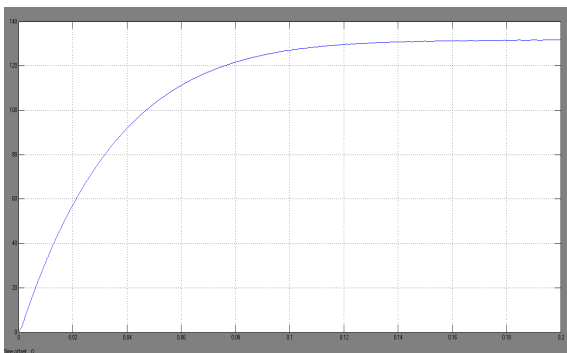

Figure 4: Mode 4 simulation results – DC voltage

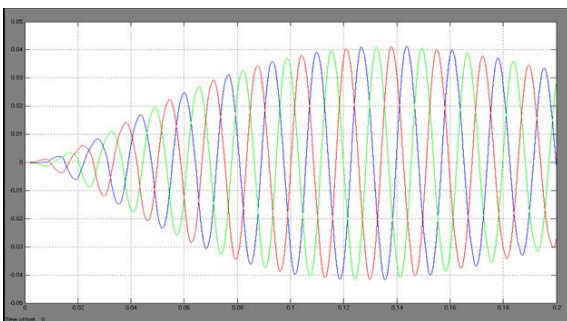

Figure 5: Mode 4 simulation results – grid voltage

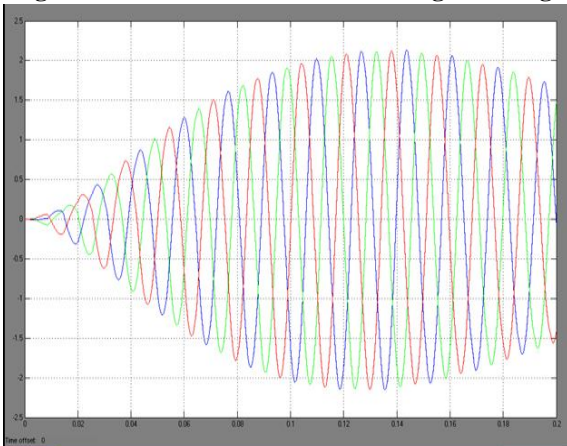

Figure 6: Mode 4 simulation results – grid current

B. Performance Investigation of the STATCOM operation mode

STATCOM operation mode is the most important aspect and difficult to design. But it provides enhanced DC fault ride through capabilities. For grid short circuit faults, traditional R12SC results the complete disconnection by opening the AC side circuit breakers. The topology presented enables the R12SC to remain connected to the grid, in case of grid short circuit faults. During the fault R12SC is additionally able to exchange reactive power with the grid. These factors not only help to stabilize the grid but significantly reduce the time needed to restore normal operation after the DC fault has been cleared.

The simulation results for the battery voltage and the reactive power exchange with the ac grid are as shown in below Figure 7 and Figure 8 respectively. These simulation results validate the satisfactory performances.

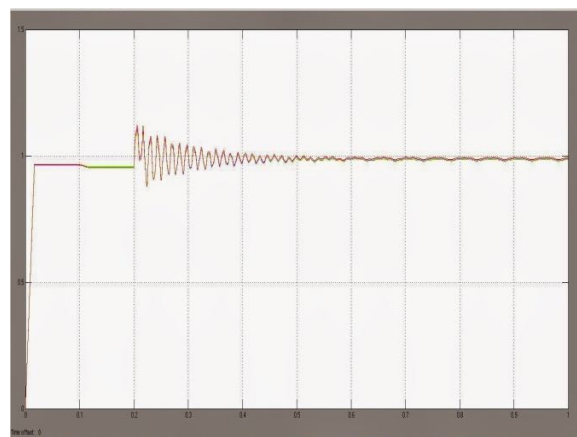

Figure 7: STATCOM simulation results – reactive power exchange

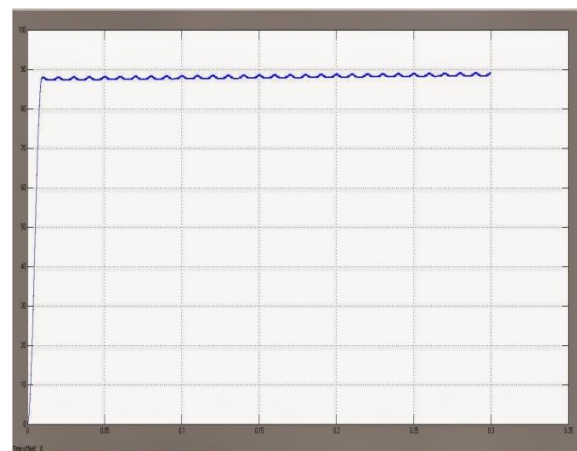

Figure 8: STATCOM simulation results – Battery voltage

IV. CONCLUSION

This paper introduced a new concept called R12SC for utility-scale solar PV-battery applications. The basic concept is to use a single 12 pulse conversion system to perform different operation modes such as PV to grid (dc to ac), Grid to battery (ac to dc), Battery to grid (dc to ac) and Battery and PV to grid (dc to ac). The proposed solution requires minimal complexity and modifications to the conventional three-phase solar PV-battery systems. The proposed solution also includes different design flexibilities suitable for wide range of customers and suppliers.

Test results have been presented to verify the concept of the R12SC and to demonstrate the various performance characteristics of the R12SC. The test results present the reduced harmonics, improved power quality etc. Therefore, the solution is very much attractive for utility-scale solar PV-battery applications.

REFERENCES

- [1] FredeBlaabjerg and Josep M. Guerrero, "Smart grid and renewable energy systems," in Proc. IEEE Int. Conf. Electrical Machines and Systems (ICEMS), 2011, pp. 1-10.
- [2] Mark Venables, "Bring me sunshine," IEEE Trans. Engineering and Technology, Vol. 3, no. 14, pp. 56-58, Oct. 2008.
- [3] U.S. Department of Energy, National Renewable Energy Laboratory (NREL), "Renewables Electricity Futures Study," Vol. 2, 2012.
- [4] Zhiqiang Gao, Song Li, Xuesong Zhou and Youjie Ma, "An overview of PV system," in Proc. IEEE Int. Conf. Mechatronics and Automation (ICMA), 2016, pp. 587-592.
- [5] Akshay S. Shirbhate and Suhas D. Jawale, "Power quality improvement in PV grid connected system by using active filter," in Proc. IEEE Int. Conf. Energy Efficient Technologies for Sustainability (ICEETS), 2016, pp. 388-395.
- [6] E. Zhou, T. Logenthiran and W. L. Woo, "Integration of a PV-battery hybrid system with the main power grid," in Proc. IEEE Int. Conf. Power Systems (ICPS), 2016, pp. 1-5.
- [7] Malu Vikraman Nair and Lekshmi S, "Reconfigurable solar converter for PV battery applications," in Proc. IEEE Int. Conf.
- [8] Electronics, Communication and Computational Engineering (ICECCE), 2014, pp. 61-66.