

# Micro-Mechanical Interactions In A Composite Laminate With Embedded Simulated Micro Sensor

Sanmati Vikas TL<sup>1</sup>, Dayananda Murthy T<sup>2</sup>

<sup>1</sup> SRINIVAS INSTITUTE OF TECHNOLOGY

<sup>2</sup> SJCE MYSORE

**Abstract-** *The study of the mechanical interaction among the host, interface, and a device embedded within a laminated composite is important. Embedding micro-sensors in composite laminates produces material discontinuity around the inclusions. This in turn produces stress concentrations at or near the inclusions. Both 2D plane strain and 3D finite-element models are developed to analyze the stress/strain state surrounding the embedded micro-sensors within a unidirectional composite laminate. The objective of the present numerical effort is to take into account the observed resin-rich areas caused by embedment, and to determine their effects on the local stress field around the embedment and the corresponding potential failure modes.*

**Keywords-** Stress/Strain Concentration, Finite Element Analysis, Matrix Micro-cracking, Composites

## I. INTRODUCTION

Monitoring functionalities into composites brings out structural integrity concerns about the effect of the inclusions on the load carrying capability, structural life and failure mechanisms. The presence of the embedded devices causes material and geometrical discontinuities which are responsible for unwanted peak values of stress/strain concentration with consequences on the stiffness reduction and the overall material performance. These bring the interest of studying the mechanical interaction among the host, interface, and the embedded devices.

Experimental studies have been conducted on the strength and failure of composite materials with embedded devices such as silicon chips, Lead zirconate titanate (PZT) sensors, or fiber optic sensors, etc. From these references it appears that in cases where the thickness of the inclusion did not alter significantly the through-the-thickness geometry of the host material, the local stress concentration values remained very small thus negligible effects on the material integrity were observed. However, in cases where the integrated devices were of not negligible size, the reduction of the strength of the embedded material as well as the damage mechanisms had to be quantified and investigated.

With regard to the effects on local stress field and failure mechanisms, a number of numerical studies have been performed on embedded optical fiber sensors in composite laminates. Among the few numerical studies on embedded rectangular implants, Chow and Graves investigated the stress and displacement fields near a soft implant inside a laminated composite material. The implant was embedded with cutting several plies of the composites. Their results indicated that the inter laminar stresses are an order of magnitude lower than the stress representing the applied far field load and the stress concentration factor was dependent on the stacking sequence.

The Analyze of inter laminar stress state surrounding an interlaced, active piezo ceramic actuator embedded within a unidirectional composite laminate. Their finite-element model appeared to be not sensitive to the transition resin layer thickness and the resin- pocket lengths. From analyze concluded that interlacing increases the strength of the composite structures with embedded actuators by redistributing the load around the inclusion and the host/inclusion interface. They also stated that the occurrence of delamination within the host is virtually independent of whether or not the inclusion is active.

In our study, a rectangular-shaped chip resistor was embedded into a composite laminate as a simulated micro-sensor. The composite laminate was made from S2/BT250E-1LV unidirectional glass-epoxy pre-impregnated. The simulated micro- sensor was placed with its length aligned with the fiber direction (Figure 1). The present paper investigates the impact on the local stress/strain field under the tensile loading condition of the resin rich area and the fiber distortion due to the embedment of the rectangular-shaped implant. FEM models are developed to analyze the stress/strain state surrounding the embedded micro-sensors. In addition, failure criteria are applied to identify and locate the damage initiation.

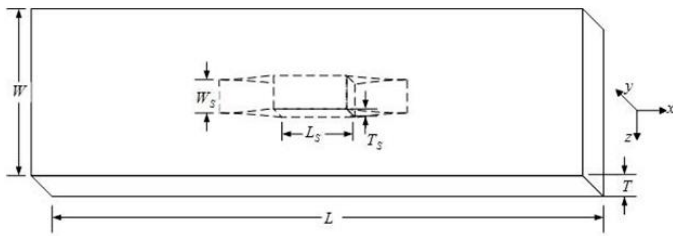

Figure 1: The embedding configuration

## II. FINITE-ELEMENTMODEL

The presence of an embedded simulated rectangular-shaped sensor in a fiber reinforced composite creates a resin pocket (Figure 2). The sizes and the shapes of the resin pockets were measured, and the dimensions were averaged for our numerical study. 2D model containing composite, resin, and sensor areas were set up to study the local stress/strain field (Figure 3).

Due to the symmetry of the idealized model, only one quarter of geometry has been considered. A plane strain state has been assumed. A 3D model has also been studied and the results compared with those given by the 2D plane strain model. However, no significant improvement has been found in terms of the stress and strain results.

Four node quadrilateral plane strain elements are mostly used in this numerical analysis. In addition, three node triangular elements are used to model the tip of the resin pocket. Figure 4 shows the local finite mesh around the resin pocket.

It can also be noticed that a finer mesh is used to discretize the domain around the sensor and particularly the resin pocket root, where maximum stresses are expected. The elements shape in these critical areas is carefully chosen to better approximate the ply distortion next to the inclusion due to its embedment within the composite.

Symmetrical boundary conditions are applied to the model with respect to the displacement in the x and y directions. A uniaxial tensile load is applied at the end of the model in the form of a uniform displacement in the longitudinal direction.

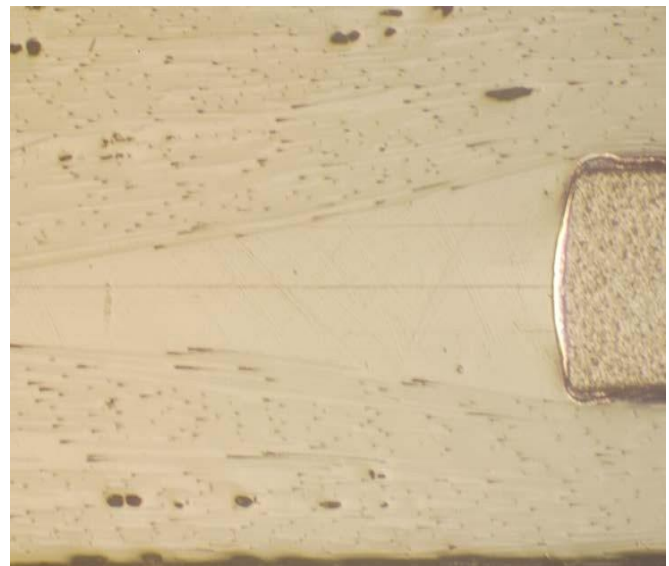

Figure 2: Micro-graph of a section of S-glass/epoxy composite laminate with embedded simulated micro sensor

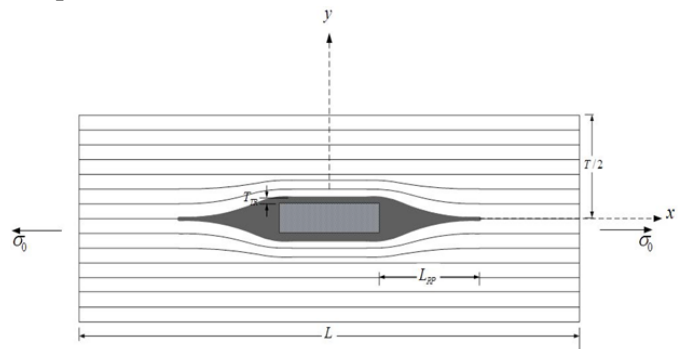

Figure 3: Idealized 2d model

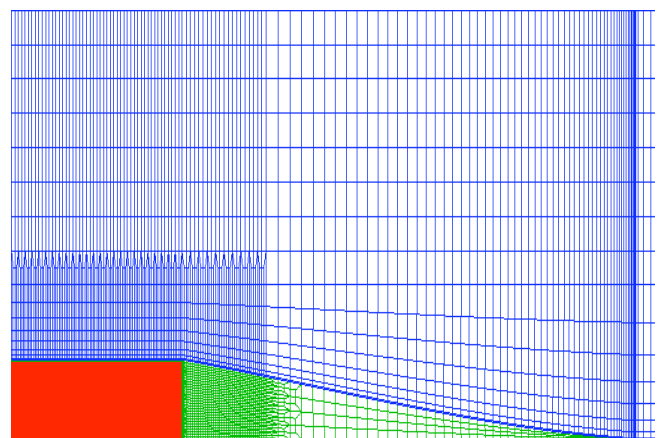

Figure 4: Local finite element mesh of 2D FEM model

## III. RESULTS ANDDISCUSSION

From the output strain field, it appears that the maximum longitudinal and shear strains occur at the sensor corners within the resin-coating interface (resin rich region). Among the three strain components, the shear strain has the maximum value. Since the neat epoxy resin can carry the least

strain among all the material components in the composite, sheared bonding at the resin sensor coating interface is expected to be the main cause of failure initiation.

The three stress components along the resin-composite and resin-sensor coating interfaces generally have the same trend. However, in the latter case, the magnitude of stress is higher. The maximum longitudinal and transverse stresses occur at the sensor corner area. At the end of the resin pocket, the transverse stress increases. However, this small increase is not enough to cause fiber-matrix splitting. The shear stresses along both interfaces show sharp rises at the sensor corners, decreasing monotonically away from the singular point.

Based on the stress distribution results from, the values of the stress applied at the far end that cause the initiation of the failure were calculated both for the composite area and the neat resin area separately.

For the composite domain, maximum stress criterion is applied. Failure is expected to occur when at least one stress component along one of the principal material axes reach its corresponding strength. The criterion is defined as follows:

$$\begin{aligned} & \text{Tension failure} \\ & \sigma_1 = F_1 \quad \text{or} \quad \sigma_2 = F_2 \end{aligned} \tag{1a}$$

$$\begin{aligned} & \text{Compression failure} \\ & \sigma_1 = -F_1 \quad \text{or} \quad \sigma_2 = -F_2 \end{aligned} \tag{1b}$$

$$\begin{aligned} & \text{Shear failure} \\ & |\tau_{12}| = F_6 \end{aligned} \tag{1c}$$

Here, the subscripts 1 and 2 refer to principal material axes of the composite material.

For the neat resin area (including the transition resin layer and the resin pocket), von Mises criterion is applied. Failure is expected to occur when the stress components

satisfy the chosen failure criterion. The von Mises criterion is defined as follows:

$$F_1' = (-3J_2')^{1/2} \tag{2a}$$

$$J_2' = -1/6[(\sigma_1 - \sigma_2)^2 + (\sigma_2 - \sigma_3)^2 + (\sigma_3 - \sigma_1)^2] \tag{2b}$$

Using these criteria and the strengths of the considered material, the failure initiation stress is predicted and the site of failure initiation is located. The predicted value shows that micro-cracks may initiate around the embedded sensor at an early stage of the loading process.

#### IV. CONCLUSIONS

The presence of the embedded micro-sensors in laminated composites is predicted to initiate premature failure. Complex micro-mechanical interactions occur at the fiber glass/epoxy laminate and the embedded simulated sensor interface.

FEM analysis has been conducted to study the effect of the embedded simulated micro sensor on the stress/strain fields and failure mechanisms within the host composite laminate. Under tensile loads, the initial failure is expected to be matrix cracking at the sensor corners in the resin-sensor coating interface. The failure initiation load is predicted using von Mises criterion.

#### REFERENCES

- [1] J. S. Sirkis, H. Singh, A. Dasgupta, C. C. Chang, 1992, Experimental determination of damage and interaction strain fields near active and passive inclusions embedded in laminated composite materials, presented at the ADPA/AIAA/ASME/SPIE Conf. on Active Materials and Adaptive Structures, 563-566.
- [2] S. Mall, J. M. Coleman, 1998, Monotonic and fatigue loading behavior of quasi-isotropic graphite/epoxy laminate embedded with piezoelectric sensor, Smart Mater. Struct. Vol. 7, 822-832.
- [3] C. A. Paget, K. Levin, 1999, Structural Integrity of Composites with Embedded Piezoelectric Ceramic Transducer, Part of the SPIE Conference on Smart Structure and Integrated Systems, Newport Beach, California, SPIE Vol. 3668, 306-312.
- [4] A. Dasgupta, Y. Wan and J. S. Sirkis, 1992, Prediction of resin pocket geometry for stress analysis of optical fibers

- embedded in laminated composites, *Smart Mater. Struct.* Vol. 1,101-107.
- [5] K. Levin, S. Nilsson, 1994, Analysis of the local stress field in a composite material with an embedded EFPI-sensor, presented at the Second European Conf.on Smart Structures and Materials, Glasgow,379-382.
- [6] N. C. Eaton, R. C. Drew and H. Geiger, 1995, Finite element stress and strain analysis in composites with embedded optical fiber sensors, *Smart Mater. Struct.* Vol. 4,113-117.
- [7] K. Shivakumar, A. Bhargava, 2005, Failure mechanics of a composite laminate embedded with a fiber optic sensor, *Journal of Composite Materials*, Vol. 39, No.9,777-798.
- [8] W. T. Chow, M. J. Graves, 1992, Stress Analysis of a Rectangular Implant in Laminated Composites Using 2-D and 3-D Finite Elements, *AIAA Journal*,848-861.