

Comparison Analysis of Circular And Intze Water Tanks on Sloping Ground Using Etabs

A.B.Khengare¹, A.A.Waghmare²

²Assistant Professor

^{1,2}Dr. V. V. P. College of Engineering, Ahmednagar.

Abstract- *The present study investigates the behavior of elevated circular water tanks and intze water tanks by Response Spectrum Analysis on varying slopes. It is carried out by considering various parameters like water storage capacity and staging height which are constant, various types of staging arrangement and variation in the ground slope. By intercombining each of these parameters 10 models of tank were created. All tank models have their locality in earthquake zone III. Dynamic response of elevated water tanks is hard to define, as the behavior of tank is unpredictable. Dynamic analysis of liquid storage tank is a complex problem involving water- structure interaction. Based on numerous analytical, numerical and experimental studies, simple etabs models of tank- liquid system have been developed to calculate the hydrodynamic forces. During the earthquake, water contained in the tank exerts forces on tank wall as well as bottom of the tank. These hydrodynamic forces should consider in the analysis in addition to hydrostatic forces.*

Keywords- Circular Water tank, Intze water tank, Response Spectrum Analysis, Etabs

I. INTRODUCTION

Response Spectrum is an advanced tool in Etabs which measures the contribution from each natural mode of vibration to indicate the likely maximum seismic response of an essentially elastic structure. Response-spectrum analysis provides insight into dynamic behavior by measuring pseudo-spectral acceleration, velocity, or displacement as a function of structural period for a given time history and level of damping. It is practical in this case to envelope response spectra such that a smooth curve represents the peak response for each realization of structural period. Hence in current work Etab program currently use in the behavior of each tank with respect to other is checked for base shear, roof displacement and plastic hinge formation sequence and its pattern within the staging.

Due to slopes there is increase in stiffness and there is a change in magnitude of displacement and base shear of the structures. There is not much change in base reaction and roof

displacement due to arrangement of columns in single layer and double layer. The structural behavior remains same for plastic hinge formation, different water storage capacity, staging heights and different number of columns. The overhead tanks are supported by the column which acts as stage. This elevated water tanks are built for direct distribution of water by gravity flow and are usually of smaller capacity. Most water supply systems in developing countries, such as India, depend on overhead storage tanks. The strength of these tanks against lateral forces such as those caused by earthquakes, needs special attention. General observations are pointing out the reasons towards the failure of supporting system which reveals that the supporting system of the elevated tanks has more critical importance than the other structural types of tanks. Most of the damages observed during the seismic events arise due to the causes like improper/unsuitable design of supporting system, mistakes during selection of supporting system, improper arrangement of supporting elements and/or underestimated demand or overestimated strength etc. Consequently, the aim of this study is to know the effectiveness of supporting systems of elevated tanks with different alteration. A reviewed literature demonstrates the considerable change in seismic behavior of elevated tanks with consideration of responses like displacement, base shear, base moment, sloshing, torsional vulnerability etc. Finally, study discloses the importance of suitable supporting configuration to remain withstands against heavy damage/failure of elevated water tanks during seismic events.

This project is concerned with the performance of two types of elevated water tank with varying slopes under seismic and wind induced dynamic loads as shown below in the fig 1.1 (a) and (b). Wind loads are considered as per IS 1911- 1967, IS 875(part3): 1987 and seismic load as per IS 1893(part1):2002. The FEM analysis of elevated water tank involves modal analysis, equivalent static, response spectrum, and wind analysis with gust factor. The results obtained from the analyses are compared and the conclusions are drawn.

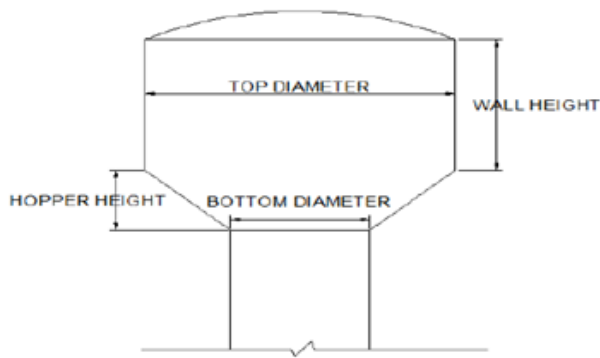

Fig. 1 General Diagram of Intze Water tank

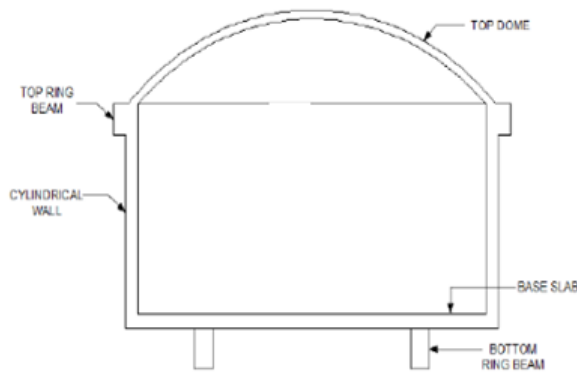

Fig. 2 General Diagram of Circular Water tank

II. OBJECTIVES

The objectives of this investigation are to study the behavior of an elevated circular and intze water tank considering the various structural and geometrical parameters using computer program. Here we shall use Etabs, Structural Analysis Program. The final conclusion will be drawn with help of graphs of Base Reaction Versus Displacement (Roof Displacement) and capacity curve for each tank from which we can compare one tank structure with other tank structures and then can predict the behavior of the same.

This paper is to be presented to serve the following objectives-

- [1] The main objective of this paper is to study the hydrodynamic effect on elevated water tank, with different shapes of the tank for constant capacities. Here circular and intze tanks are considered for study.
- [2] Also to compare the analysis results of base shear and base moment with different ground sloping conditions. Comparing impulsive and convective pressure results as they may exert pressure in different magnitude.

[3] To propose suitable supporting configuration that withstands against heavy damage/failure of elevated water tanks during seismic events.s

III. MODEL DESCRIPTION

Ten models are prepared in this study for the analysis and study.

The constant parameters in all the ten models are as below:

Table 3.1: Structure Plan Details

Sr. No.	Description	Circular tank	Intze Tank
1.	Diameter of Column	450mm	450mm
2.	Height of wall (m)	3m	3m
3.	Hopper height (m)	NA	2m
4.	Height of Staging	12m	12m
5.	Bracings	225x300mm	225x300mm
6.	Thickness of Roof Slab	200mm	200mm

IV. METHODS OF ANALYSIS

Water storage tanks are designed as per the provisions of IS 3370 and IS:11682-1985. As per the provisions of the code (IS 3370-1965), the designing of water tanks was permitted by working stress method only and on the philosophy of no cracking. This code has been revised in 2009. As per IS 3370:2009, use of limit state method has been permitted and provision for checking the crack width is also included in this code. Main features of seismic method of analysis based on Indian standard 1893(Part 1 1):2002 Seismic analysis of elevated water tank involved two types of analysis,

- 1. Equivalent Static analysis of elevated water tank.
- 2. Dynamic analysis of elevated water tank

V. METHODOLOGY

The project study involved two stages. The primary data was gathered through a Literature survey targeted by web searches and review of eBooks, manuals, codes and journal papers. After reviewing the problem statement is defined and model preparation is taken up for detail study and analysis purposes. This project execution follows the flow chart given below:

The following step describes the layout of this project briefly

- STEP 1 - LITERATURE COLLECTION
- STEP 2- STUDY ABOUT DYNAMIC ANALYSS OF ELEVATED WATER TANKS
- STEP 3- SYSTEM DEVELOPMENT
- STEP 4- MODEL INPUT GENERATION WITH CAD FILES
- STEP 5 - MATERIAL SPECIFICATIONS
- STEP 6- MODELING ON SOFTWARE
- STEP 7 - COMPARATIVE STATEMENT, MODELLING OUTPUTS
- STEP 8 - RESULTS AND DISCUSSIONS
- STEP 9 - CONCLUSION

VI. RESULT

6.1 BASE SHEAR(in kN)

The maximum responses are determined for different parameters of elevated water tanks. Response spectrum analysis for the full tank condition in seismic zones III is carried out by using ETABS software These responses include base shear force, nodal displacement and time period.

Base shear values for Circular and Intze models are obtained using Response spectrum analysis from the ETABS software

Table 6.1 Base Shear in kN with respect to X-direction

	Base Shear in kN with respect to X-direction									
	Circular Tank					Intze Tank				
	0 ^o	5 ^o	10 ^o	15 ^o	20 ^o	0 ^o	5 ^o	10 ^o	15 ^o	20 ^o
X	182.2	188.20	187.04	186.1	185.39	150.3	155.2	154.03	152.9	151.9

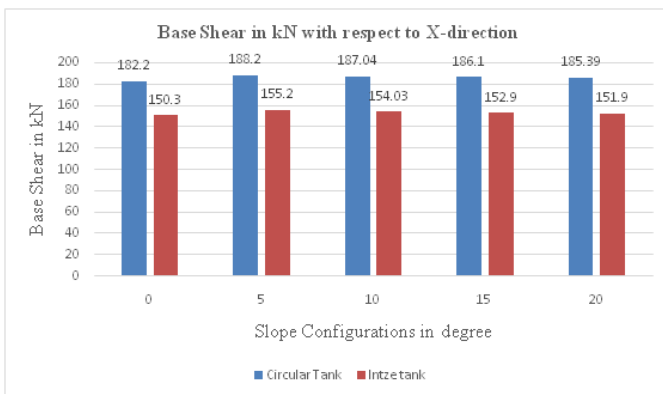

Graph 6.1 Base Shear in kN with respect to X-direction

Discussion on the Base Shear values on the models

1. The base shear for Circular tank is 17.50-18.06 % more than that of Intze type of tank for full tank condition cases of 0^o-20^o in seismic zone III.
2. 0.38% base shear decreases from 20^o cases modal of both tank for full condition.

6.2 Base Moment (in KN-m)

Base moment values for circular and Intze models are obtained using Response spectrum analysis from the ETABS software

Table 6.2 Base Moment in kN-m with respect to Y-direction

	Base moment in KN-M with respect to Y-direction									
	Circular Tank					Intze Tank				
	0 ^o	5 ^o	10 ^o	15 ^o	20 ^o	0 ^o	5 ^o	10 ^o	15 ^o	20 ^o
Y	2293.3	2428.42	2473.3	2524.7	2580.33	2134.4	2252.9	2282.72	2316.3	2352.7

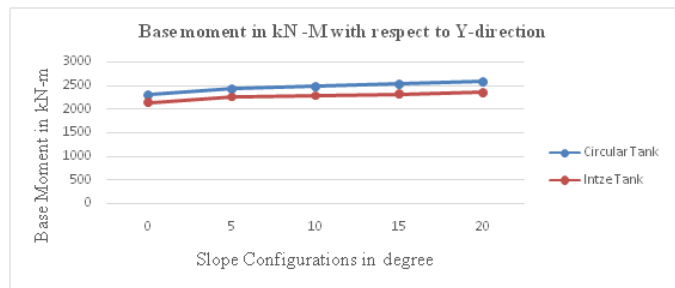

Graph 6.2 Base Moment in kN-m with respect to Y-direction

Discussion on the Base moment values on the modals

1. The base moment for Circular tank is 6.92-8.82% more than that of Intze type of tank for full tank condition in seismic zone III.

6.3 MAXIMUM DISPLACEMENT

Maximum Displacement values for circular and Intze models are obtained from Response spectrum analysis from the ETABS software under seismic zones III for Staging 5 levels of water.

Table 6.3 Maximum Displacements in circular tank and Intze tank

	Maximum Displacements in circular tank and Intze tank									
	Circular Tank					Intze Tank				
	0 ^o	5 ^o	10 ^o	15 ^o	20 ^o	0 ^o	5 ^o	10 ^o	15 ^o	20 ^o
Staging 5	6.197	6.279	6.33	6.39	4.65	6.823	6.914	6.99	7.07	5.16

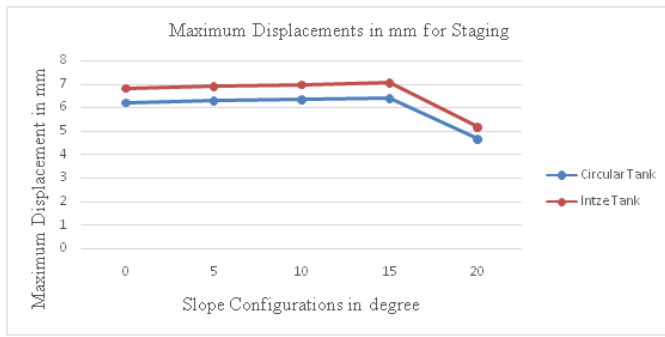

Graph 6.3 Maximum Displacements in circular tank and Intze tank

Discussion on the Maximum displacements on the modals

- 1.The maximum displacement usually occurs at top most staging 5 levels
2. The maximum displacement for Intze type of tank is 9.17-9.88% more than that of circular tank for full tank condition in seismic zone III.
- 3.27.23% maximum displacement decreases from 20° Slope Configurations modal as compare to 15° Slope Configurations modal.

6.4 TIME PERIOD

The time period is calculated for convective mode where in the liquid mass in the upper region undergoes sloshing motion this mass is called as convective liquid mass and it exerts convective hydrodynamic pressure on the tank and the base.

Table 6.4 Time periods in Intze& Circular tanks

	Time periods in Circular tank and Intze tank									
	Circular Tank					Intze Tank				
	0°	5°	10°	15°	20°	0°	5°	10°	15°	20°
1	0.677	0.686	0.692	0.698	0.704	0.672	0.681	0.689	0.697	0.705
2	0.676	0.685	0.692	0.698	0.703	0.672	0.681	0.689	0.696	0.703
3	0.383	0.387	0.39	0.392	0.394	0.416	0.419	0.421	0.423	0.425
4	0.099	0.101	0.103	0.104	0.106	0.124	0.126	0.127	0.128	0.129
5	0.099	0.101	0.103	0.104	0.105	0.124	0.126	0.127	0.128	0.129
6	0.048	0.051	0.051	0.057	0.061	0.07	0.071	0.072	0.072	0.073
7	0.048	0.044	0.048	0.051	0.052	0.07	0.071	0.071	0.072	0.072
8	0.043	0.043	0.044	0.044	0.044	0.038	0.039	0.04	0.04	0.041
9	0.035	0.042	0.043	0.044	0.043	0.037	0.038	0.039	0.039	0.039
10	0.035	0.027	0.042	0.042	0.043	0.037	0.037	0.036	0.035	0.034
11	0.014	0.024	0.02	0.018	0.017	0.016	0.021	0.019	0.016	0.015
12	0.008	0.01	0.01	0.01	0.01	0.008	0.01	0.01	0.01	0.01

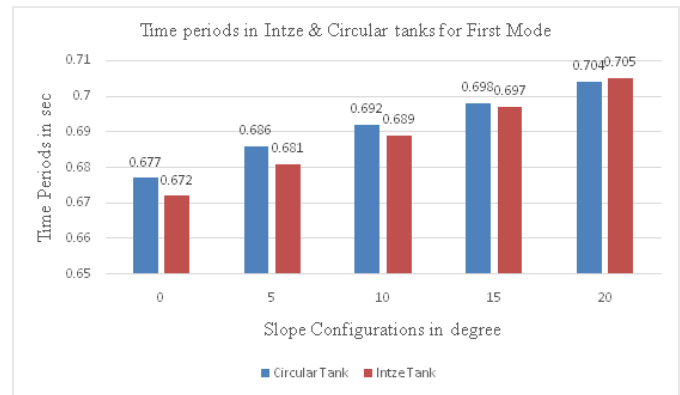

Graph 6.4 Time periods in Circular tank and Intze tank

Discussion on the time period of the models.

- The time period for Circular tank is 0.73% more than that of Intze water tank for 0°-15° Slope Configurations modal.

VII. CONCLUSION

The following conclusions have been drawn based on the results obtained from present study:

1. The base shear for Circular tank is 17.50-18.06 % more than that of Intze type of tank for full tank condition cases of 0°-20° in seismic zone III.
2. The base moment for Circular tank is 6.92-8.82% more than that of Intze type of tank for full tank condition in seismic zone III.
3. The maximum displacement for Intze type of tank is 9.17-9.88% more than that of circular tank for full tank condition in seismic zone III.
4. The time period for Circular tank is 0.73% more than that of Intze water tank for 0°-15° Slope Configurations modal.
5. The displacement value has drastically increased due to reduced height.
6. Design of water tank is a very tedious method. Particularly design of elevated cylindrical water tank involves lots of mathematical formulae and calculation. It is also time consuming.
7. For the sloping ground we saw that from our analysis for the parameter like shear force for all the cases in all the zones we found it was steeply rising to higher value as we move from column resting on lower side to column resting on higher side on a sloping surface
8. The concept of using R.C.C bracing is one of the advantageous concepts which can be used to strengthen sloping structures.

9. Large capacities circular water tanks are economical. On account of circular shape, it can make water tight easily as there as no sharp corners.
10. intze water tank is constructed to reduce the project cost due to lower domes in these constructions resist horizontal thrust.

REFERENCES

- [1] P. C. Varghese- Advanced Reinforced Concrete Design.
- [2] Ramachandra , Vijay Gehlot –Limit state of Design concrete structure
- [3] S. N. Sinha - Reinforced Concrete Design.
- [4] S. Ramamrutham - Design of Reinforced concrete structure.
- [5] Dr.V.L. Shah , Late Dr. S.r.kurve – Limit state theory & Design of Reinforced concrete
- [6] IS 456-2000 Indian Standard Code of Practice for Plain and Reinforced Concrete, Bureau of Indian Standards, New Delhi.
- [7] IS: 1893 (Part 1), (2002), Indian Standard Criteria for Earthquake Resistant Design of Structures, Bureau of Indian Standards, New Delhi.
- [8] IS: 1893 (Part 2), (2002), Indian Standard Criteria for Earthquake Resistant Design of Structures, Liquid Retaining Tanks,Bureau of Indian Standards, New Delhi.
- [9] IS: 1893 (Part 4), (2002), Indian Standard Criteria for Earthquake Resistant Design of Structures, Industrial structures including stack-like structures Bureau of Indian Standards, New Delhi.
- [10] IS: 875 (Part 2) – 1987: Imposed loads.
- [11] IS: 875 (Part 3) – 1987: Wind loads
- [12] The other code books referred for this project are, SP 16 (design aids for IS 456), IS 875 – Part I, II, III, V.
- [13] Bojj.MKMVRatam Dr, U Ranga Raju - Effect of Staging Height On the seismic performance of rcc elevated water tank International Research journal of engineering and Technology (IRJET) ISSN(online):2319-8753
- [14] Sandeep TD - Comparative studies on elevated water tank due to dynamic loading. International Research journal of engineering and Technology (IRJET) E-ISSN2395-0056.
- [15] Ms. Pranjali N. Dhage , Mr. Mandar M. Joshi- Review Study on Comparison between Static and Dynamic Analysis of RCC Water Tank-International Journal of Research in Advent Technology (IJRAT) (E-ISSN: 2321-9637) Special Issue National Conference “CONVERGENCE 2017”, 09th April 2017
- [16] Soheil Soroushnia, Sh. TavousiTafreshi, F. Omidinasab, N. Beheshtian, SajadSoroushnia- Seismic Performance of RC Elevated Water Tanks with Frame Staging and Exhibition Damage Pattern- Procedia Engineering 14 (2011) 3076–3087.
- [17] NankarAnlket R., NavaleShrikantS.,Palve Gaurav A.- Evaluation of seismic forces on elevated water tank. . International Research journal of engineering and Technology (IRJET) E-ISSN2395-0056
- [18] Dhiraj Virkhare, Prof. Laxmikant, Vairagade ,Vikrant Nair .The behavior of an elevated circular water tank by pushover analysis - International Research journal of engineering and Technology (IRJET).
- [19] Nishigandha R. Patil, Rajashekhar S. Talikoti - Seismic Behavior of Elevated water tank -IJRET: International Journal of Research in Engineering and Technology eISSN: 2319-1163 | pISSN: 2321-7308.
- [20] AazhussainM.Jabar ,H.S.Patel - Seismic Behavior of elevated water tank under different staging pattern and earthquake characteristics . International Research journal of engineering and Technology (IRJET) E-ISSN2249-8974
- [21] Issar Kapadia, Nilesh Dholiya, Purav Patel and Prof. Nikunj Patel “Parametric study of RCC staging (support Structure) for overhead water tanks as per IS: 3370”, IJAERD, Volume 4, Issue 1, January -2017.
- [22] S.C. Duttaa, S.K. Jainb, C.V.R. Murty- Alternate tank staging configurations with reduced torsional vulnerability-Soil Dynamics and Earthquake Engineering 19 (2000) 199–215