

Design And Analysis of Rectangular UWB Patch Antenna With Metamaterial Design

Kanchan Kumari¹, Vaibhav Purwar², Yashwant Mohan³

^{1, 2, 3} Dept of Electronics & Communication

^{1, 2, 3} KIT Kanpur, India

Abstract- This Paper Present the idea of recent developments and advancements in the field of wireless technology to realize high speed communication which is performed in wideband technology. In this paper the wideband rectangular patch antenna is designed and fabricated using metamaterial unit cell. A patch antenna is notch-band, wide beam antenna which is fabricated by etching the antenna element pattern in metal trace bonded to an insulating dielectric substrate, such as a Aluminum 96%, at which a continuous metal layer bonded to the opposite side of substrate PEC and it produce a ground plane. The proposed antenna resonates at 6.5GHz with total field directivity 11.97dBi, which improved result than other patch design. The design has been made on low cost material aluminum lossy. This paper also compares an out put of a rectangular patch antenna with metamaterial antenna designed here. The simulation is done using CST Microwave Studio simulating software.

Keywords- Ultra wide band (UWB); Wireless local area network (WLAN); Industrial Scientific, and Medical Band (ISMB); split ring resonator(SRR); Microstrip Patch antenna(MPA).

I. INTRODUCTION

In radio telecommunication, among the antenna designs there are many different categories of micro strip antennas which are also known by the name printed antennas the most common of which is the micro strip patch antenna or patch antenna. A patch antenna(also known as circular micro strip antenna) is a type of radio antenna with a low profile which can be constructed on a flat surface. It consists of a flat circular metallic sheet or “patch” of metal, mounted over a large metallic sheet called ground plane. The assembly is usually covered by a plastic random, which saves the antenna structures from damage. Patch antennas are very simple to be fabricated and easy to be modified and customized. They are the original type of micro strip antennas which were given by Howell in year 1972 in which the two metal sheets tighter produce resonance and form a resonant piece of micro strip transmission line with a length which is around one fourth wavelength of the guided waves. The radiation process arises from discontinuities or regulation at each truncated edge of the

micro strip transmission line. The radiation produce at the edge causes the antenna to act slightly bigger electrically than its actually physical dimension, so in order for the antenna to be resonating piece of elements, a length of micro strip transmission line slightly lesser than one fourth a wavelength at the frequency is taken. A dielectric substrate Aluminum 96% loss free is used for the construction of patch antenna . The easiest and most simple patch antenna uses a patch which is one fourth wavelength long, created at a precise distance above a larger ground plane, using an intermediary such as a space made of a dielectric material between them.

Electrical large ground plans produce very rugged and stable patterns and lower environmental sensitivity but of course increase the size of antenna. It isn't uncommon for the ground plane (60mm×40mm×1mm)to be only slightly larger than the active patch. When a ground plane is near to the size of the radiator it can have the phenomenon of coupling and produce currents along the edge of the ground plane which also radiate. The antenna pattern is created as the combination of two sets of radiating metallic element. The current which flow is along the direction of feed wire, so magnetic vector potential and also the electric field follow the current. A simple and easiest patch antenna of this category radiates a linearly polarized wave. The radiation can be considered as being produced by a number of the “radiating slots” at top and bottom, or simultaneously as a result of the current flowing on the patch and the ground plane .Commonly made micro strip antenna shapes are square, rectangular, circular and elliptical, but any continuous shape is possible and can be created. Some patch antenna do not use a dielectric substrate and inserted are made by using a metal patch mounted above a ground plane using dielectric spacers; the resulting structure is less rugged but the band width is much wider. Now as such antenna have a very low profile, are mechanically rugged and can be shaped and designed to conform the curving skin of a vehicle, they are often mounted on the exterior of aircraft and spacecraft, or are incorporated and operated into the electronic devices such mobile radio communication equipment.

Recently a new fictitious material has been practically developed known as metamaterials. It has amazing specific electromagnetic properties that are not found in

naturally occurring materials. Metamaterial are man engineered materials. It has negative permittivity(ϵ) and permeability(μ).

Antenna features such as frequency, radiation pattern and polarization re reconfigured to achieve the demand for agile radio application. A lot of researches focus on frequency reconfiguration as future communication systems such as cognitive radio needs an antenna that can do spectrum sensing and communication. In design of reconfigurable frequency antennas, recently a reconfigurable wide-band to agile narrowband frequency, using a printed log periodic dipole array antenna, was developed. A wideband slotted antenna has been produced using multifunctional reconfigurable frequency characteristics for various applications such as Wireless LAN, WIMAX, Ultrawideband and UMTS has been proposed in a frequency reconfigurable antenna, made up of two structural elements ; one is an ultra-wide band (UWB) and other is a frequency reconfigurable elliptical shaped antenna, is proposed for cognitive radio application

This antenna covers a range of frequency of 2.4 GHz to 6.5 GHz with extreme directivity of 11.97 dBi. During 4.5 GHz to 6.5GHz the VSWR is quite low, shows good matching with transmission line. Ultra-wide band antenna have already been used in application such as satellite communication, remote sensing, ultra-wide band radar technology and so on. Currently the wireless are network (WLAN) in the 2.4 GHz (2.4-2.485 GHz) and 6.5 GHz (4.25-6.5 GHz) bands is the most renowned networks for accessing the internet and also the antenna for an AP not only requires dual band operation but also need to have an appropriate radiation profile in both bands, namely equal gain, wide beam width and high front to back ratio. wireless communication is enjoying exponential growth in industrial, Scientific, and Medical (ISM) band. The future generation wireless networks requires systems with board band capabilities in various environment to satisfy numerous application as smart grid, personality communication, home, car and office networking. On the otherhand ,many modern wireless communication systems such as radar , navigation satellite and mobile application use the circularly polarized (CP) technology and radiation pattern. for the best UWB performance , the transmitter and receiver (T/R) antennas should have flat and high directive gain , narrow beam achieve the largest dynamic range ,best focused illumination area lowest T/R coupling ,reduced ringing and uniformly shaped impulse radiation. UWB has generally offers high data rates at short distance with low power, primarily due to high resolution bandwidth.[7-11]

II. DESIGN AND CONFIGURATION OF ANTENNA

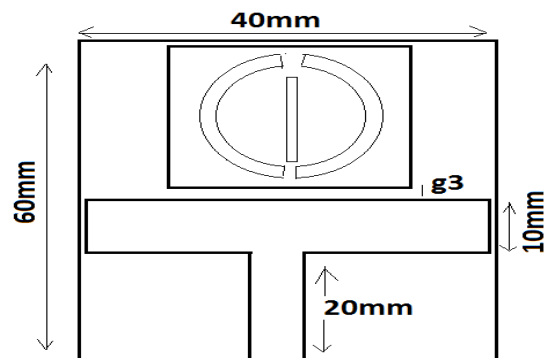

Fig.a Patch antenna

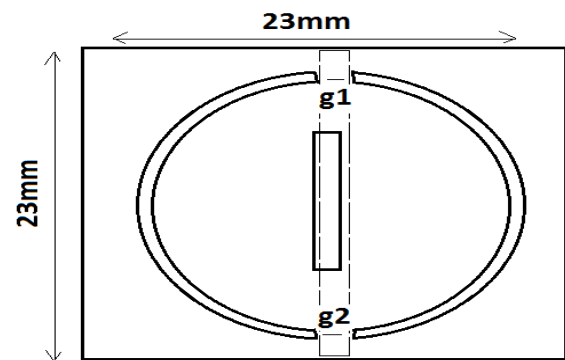

Fig.b Metamaterials Design used figure -1

The geometry and configuration of the proposed antenna is shown in the figure-1. Here we have designed a single layered planar DNG antenna photo etched on thin substrate. First we have taken a ground plane of 0.4mm next rectangular substrate (60mm×40mm×1mm) of Aluminium 96% having permittivity 9.9 is developed. A circular patch having radius 8mm, thickness 0.3mm, and a gap circle having outer radius 6mm and inner radius 9.8 mm is printed on the substrate .as shown in the figure-1 at the centre point of the patch, a via of radius 0.2mm is inserted. For feeding we have used a microstripline of length 19.2 mm, width 4.8mm and thickness 0.3mm, by using the above dimensions a gap of $g_2=g_3= g_1 = 2\text{mm}$ is found between the microstrip line and the patch. Our antenna is simulated using CST Microwave Studio based on finite integration method. But the CST transient solver doesn't support negative permittivity and permeability we can't enter negative permittivity and permeability values for metamaterial directly, so we have used a via (inductive), a circular gap in the patch (conductive) and a gap of 0.2mm between the patch and the microstripline (capacitive) to directly convert the Aluminium 96% patch to DNG metamaterial. Directly, negative permeability and

permittivity values can be entered using CST, based on finite element method.

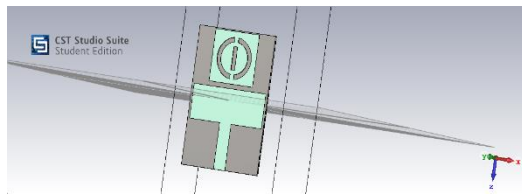

Figure.2

A. Circular patch

The most commonly designed microstrip antenna is a Circular patch. The Circular patch antenna is around a one fourth wavelength long strip of rectangular micro strip transmission line. When air is taken as substrate, the length of Circular micro strip antenna is approximately one fourth of free space wavelength. Antenna is loaded with a dielectric substrate. The length of the antenna reduces as the relative dielectric constant of the substrate element increases. The resonant length of the antenna is slightly lesser because of the increased electric “fringing fields” which increase the electrical length of the antenna slightly. An old model of the micro strip antenna is a section of micro strip transmission line with equivalent loads on the either end to represent the radiation loss.

B. Planar inverted F antenna

Another category of patch antenna is the planar Inverted-F Antenna (PIFA) common in cellular phones with built-in antennas. (The planar Inverted-F antenna (PIFA) is highly used in the mobile phone market. The antenna is resonant at a quarter wavelength (thus decreasing the required space needed on the phone), and also typically has good SAR properties. This antenna resembles an inverted F, which explains the PIFA name. The Planar Inverted-F Antenna is renowned because it has a low profile and an omni-directional pattern. These antenna is produced from a quarter wave half patch antenna. The shorting plane of the half patch is decreased in length which decreases the frequency of resonance. Often PIFA antennas have multiple branches for resonating at the multiple cellular bands. On some phones, grounded parasitic elements are applied to improve the radiation bandwidth characteristic [14-16]

C. Advantages

Micro strip antennas are comparatively inexpensive to manufacture and fabricate because of the easy 2-dimensionally physical construction and geometry. They are

usually employed at UHF and other higher frequencies because the size of antenna is directly related to the wavelength at the frequency of resonance. A single patch antenna gives a maximum directive gain of around 6dB to 11dB. It is relatively easy to print an array of patches on a single (larger) substrate and lithographic techniques are used for this. Patch arrays can give much higher gains than a single patch at little additional expense; matching and adjustment of phase can be performed with printed micro strip feed structures, again in the same operations that produced the radiating patches. The capability to create high gain arrays in a low profile antenna is one that patch arrays are commonly used on airplanes and in other military applications. Such an array of patch antennas is an easy way to design a phased array of antennas with dynamic beam forming capability. An advantage inherent to patch antennas is the skill to have polarization diversity. Patch antennas can easily be fabricated to have vertical, horizontal, right hand circular (RHCP) or left hand circular (LHCP) polarization or different kinds of polarization, using multiple feed points, or a single feed point with asymmetric patch structures. This unique feature enables patch antennas to be used in many types of communication links that may have varied requirements.

III. PATCH ANTENNA DESIGN CONSIDERATION

Wideband antenna are designed and fabricated for smart grid application with a frequency bandwidth of 46% and gain of 35db to 40db. The antenna design and simulation was carried out using CST Microwave Studio that is the computer simulator technology software which is the student standard simulation tool for the simulation of 3D full wave electromagnetic field. The most commonly employed micro strip antenna is a Circular patch. The rectangular patch antenna is around a one fourth wavelength long strip of rectangular micro strip transmission line. When air is kept as antenna substrate, the length of the Circular micro strip antenna is approximately one fourth of a free space wavelength. The length of antenna reduces as the antenna is loaded with a dielectric as its substrate as well as the relative dielectric constant of the substrate highly increases. The resonant length of the antenna is slightly lesser because of the increased electric “fringing fields” which improved the electrical length of the antenna a little. An old model of the micro strip antenna is a strip of micro strip transmission line with equal loads on either end to represent the radiation losses. It is possible to fabricate patch antennas that radiate waves which are planewave polarized. One approach is to excite a single circular patch using two feeds, with one feed with a phase difference of 90 with respect to the other. This derives each transverse mode and with equal amplitudes and the

required 90 degrees out phase. Each mode radiates separately and combines to produce circular polarization. This feed condition is often available using a 90degree hybrid coupler. When the antenna is fed in this manner, the vertical current flow is maximized and is high as the horizontal current becomes zero, so the radiated electric field will be vertical; one quarter cycle later, the situation will have reversed and becomes opposite and the field will be horizontal. The radiated field rotates in time, producing a circularly polarized wave. An alternative is to use a single feed but introducing some sort of asymmetric slot or other feature on the patch, causing the current distribution to be completely displaced . A circular patch which has been perturbed slowly to produced a circular micro strip antenna can be driven along radii and create circular polarization. The aspect ratio of this is chosen so each orthogonal mode is both non resonant . At the driving point of antenna one mode +45 degrees and the other -45 degrees and it is required to produced the 90degree phase shift for circular polarization.

IV. RESULTS AND DISCUSSION

Now in this section the rectangular patch antenna is designed and the numerical and experimental results regarding the radiation characteristics are presented and discussed. The simulated results are obtained by using the CST Microwave simulation software. The measured and simulated characteristics of the antenna are shown from the far field report of the circular plot, the 2D and 3D polar plot and radiation characteristics.

A diagrammatic radiation pattern for a linearly-polarized 2.4-6.5 GHz rectangular patch antenna is presented below. The figure shows a cross – section of horizontal plane; the pattern in the vertical plane resembles though it is not exactly identical. The scale is logarithmic, so the power radiated at 180 degrees (90 degree to the left of the beam center) is about 15 db less than the power in the center of the beam. The beam width is around 65 degree and the gain is approximately 35db . An infinitely –big ground plane prevents any radiation which comes to the back of the antenna (angles from 180 to 360 degree) , but the actual antenna has a fairly short ground plane, and the power which comes in the backwards direction is only around 40dB down from that in comparison to the main beam.

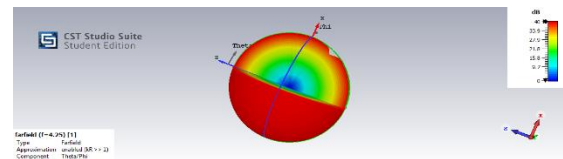

Fig.a

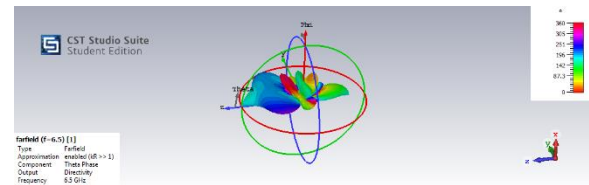

Fig.b
figure.5

Unlike other antennas mentioned in literature to date, the proposed antenna presents a good directivity and gain radiation pattern even at the 2.4-6.5GHz frequency. The designed antenna has a very small size and even the return loss in low and radiation pattern characteristics are obtained in the frequency band which is used, The simulated and experimental results gives the idea how that the proposed antenna could be a good candidate for UWB applications.

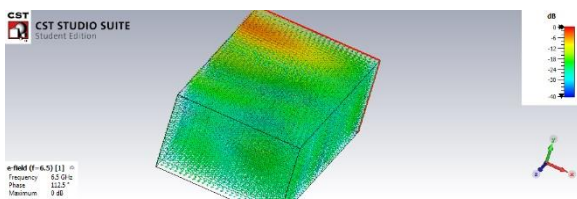

Figure.3

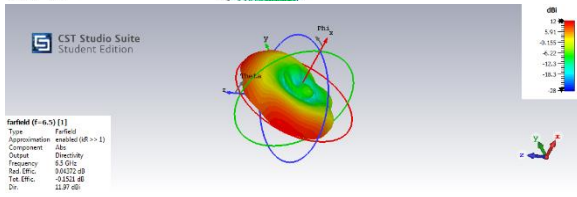

Figure.4

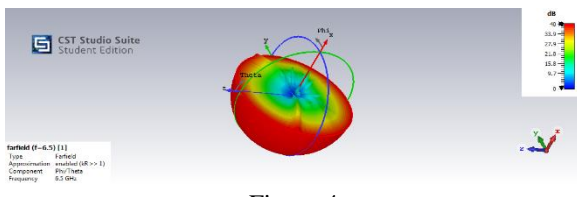

Figure.4

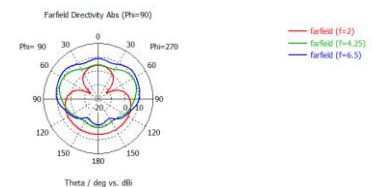

Figure.6

The beam width is around 65 degree and the gain is approximately 40db.

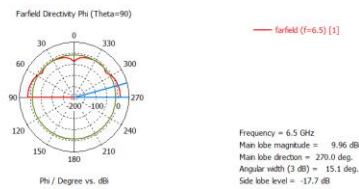

Figure.7

As the length of the patch, half a wavelength, is about the similar as the length of a resonating dipole, we get about 3db of gain out of the directivity relative to the vertical axis of the patch antenna. If the patch is completely square, the pattern in the horizontal plane will be directional, somewhat as the patch were a pair of dipoles which were separated by a half wave; this counts for another 2-3 db. Finally, the addition of ground plane removes most or all radiation of behind the antenna, decreasing the power averaged over all directions by a factor of around 2 (and thereby increasing the gain by a factor of 3db). Summing this all up, we get 35-40 db gain and 8.893-11dBi for a rectangular element patch, in good agreement with more recognized approaches.

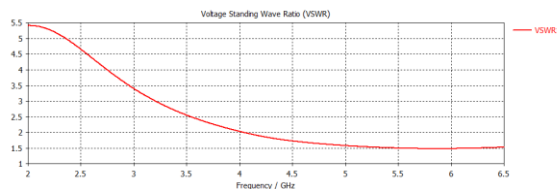

Figure.8

V. CONCLUSION

By observing the simulated results it is very clear that the compact DNG Metamaterial antenna gives better gain and efficiency compared to an ordinary patch antenna which is very useful for point to point wireless propagation. This is possible only because of the unusual properties of Metamaterials. Also due to the miniaturization it is very convenient to use in wireless networks. This is possible only because of the unusual properties of Metamaterials. Due to the unusual properties of the Metamaterials by using a single unit cell the antenna gives of 3.768 dB, overall efficiency of 52.76 and a VSWR of 1.6 at 4.45GHz to 6.5 GHz frequency which is very good for point to point wireless communication and wireless LANs. This antenna has better VSWR, gain and radiation efficiency compared to an ordinary patch antenna. And the antenna directivity is 8.87dBi at 4.5 GHz and 11.97dBi at 6.5 GHz. And the gain, efficiency and return loss are 4.183 dB, 60.78%, -14.5 respectively for 2.4 GHz. The results obtained through "CST MICROWAVE STUDIO" design software and are very good for wirelessly access network resources at home and elsewhere with up to 5 GHz performance, like IEEE 802.11a, widely available IEEE

802.11b, downwardly compatible IEEE 802.11g, and advanced IEEE 802.11n.

REFERENCES

- [1] M.SANAD, 'A small size micro strip antenna circuit,' IEEE international conference on antenna and propagation, vol. 1 pp, 465, 471 April 1995.
- [2] K, Bhsieh, M.H Chen, and K.L Wong, "single feed dual band circularly polarized Micro strip antenna," Electron. Lett. VOL. 34 pp. 1170-1171, Jun-1998.
- [3] LTCC hybrid coupler, "RCP1850S03N" RN2 Technology co. Zhen-yu Zhang, YOUNG-XIN Guo, Ling Chuen Ong, Chia M.Y.W., "A new wide band planar balun on a single layer PCB", Microwave and Wireless Components Letters, IEEE, VOL.15, NO.-6, pp.416-18, Jun-2005.
- [4] Gaboardi P., Rosa L., Cucinotta A., and seller S., "patch Array Antenna for UWB Radar Application," in 3rd European Radar Conference, 2006, p.281-284.
- [5] Wang Yazhou, Su Donglin, Xiao Yongxuan, "Broadband circularly polarized square micro strip antenna", Antennas, propagation and EM theory, 2006, ISAPE 2006 7th international symposium on, pp.1-4, 2006.
- [6] G.augustine, S.V.shynu, C.K.aanandan and K.Vasudevan "Compact dual band antenna for wireless access point," Electron Lett, Vol.42, no.9, pp. 502-503, Apr. 2006.
- [7] F.Ghanem, P.S.Hall and J.R.kelly, "two port frequency reconfigurable antenna for cognitive radios", Electronics Letters, Vol.45, 2009, pp. 534-536.
- [8] E.Ebrahim, J.R.Kelly and P.S.HALL, "A RECONFIGURABLE NARROWBAND antenna integrated with wideband monopole for cognitive radio application," IEEE Antenna and propagation society international Symposium (APSURSI), 2009.
- [9] J.W.BAIK, S.PYO, T.H.LEE and Y.S Kim, "switchable printed Yagi Uda antenna with pattern reconfiguration," ETRI journal, vol.31, 2009, pp 318-320.
- [10] P.Suraj and V.R.Gupta, "Analysis of a rectangular Monopole patch antenna" International Journal of Recent trends in engineering, Vol 2, no.5, pp. 106-109, November-2009.
- [11] C.R.Medeiros, E.B.Lima, I.R.Costa, and C.A.fernandes, "wideband slot antenna for WLAN access point," IEEE Antenna Wireless propagate.Lett., vol.9, pp. 79-82, 2010.
- [12] S.W.Su, "Concurrent dual band six loop antenna system with wide 3-dB beam width radiation for MTMO access point," Microwave Opt Tech Lett, vol.52, no.6, pp 1253-1258, Jun 2010.
- [13] M.N Srifi, M.meloui and M.Essaidi, "Rectangular slotted patch Antenna for 5-6 GHz Application," international

- journal of microwave and optical Technology, Vol.5 No.,pp 52-57 March 2010.
- [14] S.W.Su, 'High gain dual loop antenna for MTMO access point in the 2.4/5.2/5.8 GHz bands,'IEEE trans. Antenna Propag., vol.58, no.7, pp.2412-2419, jul-2010.
- [15] Letestu and Ala sharaiha, "Size reduced multi-band printed quadrifilar helical antenna."IEEE Trans, Antenna Propag., vol.59, pp 3183-3143, 2011.
- [16] A siligaris et al., "A 65-mm CMOS fully Integrated transceiver module for 60-GHz Wireless HD applications,"IEEEgournal of solid-state circuits,vol,46, no.12,pp. 3005-3017, Dec.2011.
- [17] G.P.jin, D.L.zahang and R.L.Li, " optically controlled reconfiguration antenna for cognitive radios application', Electronics letters, vol.47, pp.948-950,2011.
- [18] S.Manafi, S.Nikmehr, and M.Bemani, "Planar reconfigurable multifunctional antenna for WLAN/wimax/ UWB/pcsdcS/UMTS application,"progress In electromagnetic Reasearch C, Vol. 26,123-137, 2012.