

IOT Based Continuous Observing and Controlling of Industrial Parameters and Giving Security By Utilizing Remote Sensors and Raspberry PI

Mr.Ambrayya¹, Mr.Aswatha Narayana²

^{1,2} Assistant Professor

^{1,2} Ballari Institute of Technology and Management Collage-Ballari-583103

Abstract- This paper depicts the execution of observing and controlling modern parameters through IOT(Internet of Things) application. The everincreasing prerequisites for data being open whenever, from wherever, in any case the kind of remote gadget or arranged task, together with the need of finish control of a particular situation or gadget has made ready towards the following mechanical upheaval: Web of Things (IOT). The parameters are detected by the separate sensors and are checked and controlled by the processor. At long last, the qualities are shown with the assistance of LCD (Fluid Gem Show) show. The processor is associated with the PC and the yield will be shown in that PC with the assistance of serial correspondence. This information is put away in the Pc. The framework is dependable and stable. It is the best and most sparing methods for gear security observing and controlling.

The primary target is to outline an effective and powerful framework to control the parameters causing to industry and to limit the impact of these parameters without influencing the plant or common habitat. The proposed technique is to show a framework to peruse and screen parameters and to advise contamination control specialists when any of these elements goes higher than industry standards. Introduced in this proposed philosophy, which will consequently screen when there is an unsettling influence influencing the framework. The framework explores level of pH in industry effluents, level of CO gas discharged amid industry process and temperature of the hardware. With the plan of GSM, the signs can be viably exchanged and the activities in these cases can at present be made precise and compelling. In this way through this thought attempt to demonstrate that control of hazardus can be limited and the information can be exchanged on the web. Our proposed technique is more exact to infer the coveted parameters

Keywords- IIoT, Wireless sensors, Raspberry-Pi.

I. INTRODUCTION

Mechanical improvements have empowered to be assumed exemplary framework position via programmed and propelled framework. In addition, the accessibility of quick handling, steady and touchy items gave specific advantages in mechanical mechanization. Because of the improvement in correspondence innovation, framework are never again to be checked and controlled by faculty by utilizing great strategies, yet consequently by PC controlled or remote controlled gadgets. Modern natural conditions have been updating step by step with this recently presented programmed strategies because of disposing of the traditional methodology of assembling expanding efficiency of the framework by diminishing labor.

The cutting edge ventures will be certainly further developed and programmed as contrasted and existing ones. This expedites another wording of "savvy industries" in this new time of observing and in addition controlling of different mechanical applications. As a rising innovation got fast advances present day remote media transmission, Web of Things (IOT) as pulled in a great deal of consideration and is required to convey advantages to various applications. The recently presented idea of "Web of Things"(IOT) is giving some assistance to accomplish the modern robotization through remote access. In IOT every gadget or gadgets constituting a framework will have the capacity to speak with alternate gadgets or framework in the same premises over a typical platform. Hence this prompts trade of pertinent information, insights, logs and different parameters data among different gadgets to enhance the performance, which will assist industries with having better productivity, management and expanded throughput. Presently days, the modern checking field requires more manual capacity to screen and control the mechanical parameters, for example, temperature, mugginess, gas and so forth. This is the most forthcoming issues in the modern parts. On the off chance that the parameters are not checked and control legitimately, it prompts an unsafe circumstance. A considerable lot of the

enterprises are confronting those sorts of circumstance in view of some manual mix-ups.

To beat this issue utilizing mechanical computerization with web of things. Remote SENSOR Systems (WSN) has been utilized to gather information about physical wonders in different applications, for example, living space observing and reconnaissance. As a rising innovation realized quick advances in present day remote media transmission, Web of Things (IOT) has pulled in a ton of consideration and is relied upon to convey advantages to various application zones including mechanical WSN frameworks. Remote Sensor System (WSN) frameworks are appropriate for long haul mechanical. There is a developing enthusiasm for utilizing Web of Things (IOT) advances in different enterprises. Various mechanical IOT (Web of Things) ventures have been led in zones, for example, farming, sustenance preparing industry, ecological checking, controlling and security reconnaissance, and others. There has been much research and different endeavors to apply new Web of Things (IOT) innovation to modern regions. In this paper security is given to expand the efficiency of the framework, if security isn't given then unapproved individual goes into the confined zone of the business. So the security is given utilizing IOT and biometric sensor.

II. PROPOSED FRAMEWORK:

The primary target is to outline an effective and powerful framework to control the parameters causing to industry and to limit the impact of these parameters without influencing the plant or common habitat. The proposed technique is to show a framework to peruse and screen parameters and to advise contamination control specialists when any of these elements goes higher than industry standards. Introduced in this proposed philosophy, which will consequently screen when there is an unsettling influence influencing the framework. The framework explores level of pH in industry effluents, level of CO gas discharged amid industry process and temperature of the hardware. With the plan of GSM, the signs can be viably exchanged and the activities in these cases can at present be made precise and compelling. In this way through this thought attempt to demonstrate that control of hazardous can be limited and the information can be exchanged on the web. Our proposed technique is more exact to infer the coveted parameters.

In any confined territory of the business, the security turns into an imperative undertaking, acknowledgment can be accomplished by utilizing propelled programming device. By thinking about working room is the limited zone and important to give security, at first spare the administrator thumb picture

by catching bio metric sensor. While entering any individual into the working room, catching section individual thumb picture persistently and thumb acknowledgment is done here, once if section individual face picture is perceived then administrator window is opened else it can't be open. What's more of this undertaking computerized observing of mechanical variable parameters framework plays an imperative part is to expand the profitability of the business. On the off chance that the administrator window is opened then administrator can ready to screen all the required parameters and he can set the edge farthest point of the parameters, if any required parameters crosses as far as possible then administrator can ready to show the visual message in fluid gem show and furthermore giving discernible alarms to the administrator. In this venture if the administrator is outside of the working room, SIM card is embedded in GSM module and keeping in mind that programming enter the administrator one of a kind parameter in front board, and if any unsafe parameters crosses as far as possible then GSM sends ready message to the administrator.

Mechanical checking and control is a blend of designs, components, and calculations utilized as a part of the modern manufacturing plant for observing and control the exercises of modern procedures, engines, machines and gadgets utilized in industry premises to accomplish the objective. Despite the fact that it sounds adequate to have a savvy mechanical condition sooner rather than later however it will likewise need to confront obstacles of taking care of enormous information as every one of the gadgets will speak with each other and trade their data over a typical stage. The present undertaking is centered around Modern applications that will be ceaselessly observed through an arrangement of sensors that constitutes a sensor module. The sensor module gathers the significant information to decide if the applications to be observed are functioning admirably under certain edge esteems. The information from different sensors in the sensor module is bolstered to the controlling gadget essentially a microcontroller. This controlling gadget is interfaced with a GSM module to get got to remotely by clients. The controlling gadget all the while advances information to the principle server. The principle server situated at the business premises shows the relating information got from the controlling gadget.

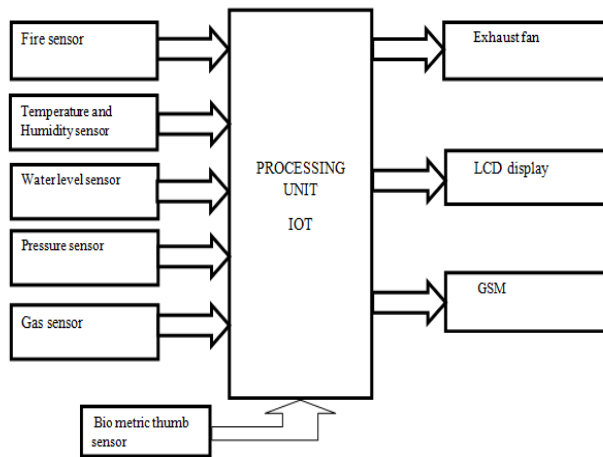

Fig 1: Block diagram

The equipment unit of the model of the framework is spoken to by the square graph beneath. It contains ARDUINO UNO (ATmega328) Microcontroller as the fundamental preparing unit. The framework comprises of two units: Sensor unit, Server unit.

- Sensor unit comprises of miniaturized scale controller, sensors like temperature sensor, moistness sensor, gas sensor, current sensor.
- Server unit comprise of PC

Checking the different parameters, for example, temperature, stickiness, weight, fire, stream and gas is detected by their related sensor. This all amounts are in simple frame. This can never read by microcontroller so all these simple signs are changed over into advanced flags by the utilization of inbuilt ADC. These advanced framed signs are exchanged to the microcontroller. At the same time every one of these parameters are send to the PC/PC and Android Portable by interfacing a GPRS (General Bundle Radio Administration) Modem. Microcontroller is heart of entire framework, if the microcontroller neglects to work by any mean, at that point the entire framework won't work. Sensors esteems will read specifically by microcontroller. The modern parameters are controlled by their particular gadgets like Fumes fan, valves, dc engine and so forth. In this model, for security reason we are utilizing Biometric module. In this venture there is no need of changing over simple flag into advanced flag of sensors in light of the fact that ARDUINO UNO Microcontroller comprises of inbuilt simple to computerized converter. So now interface temperature sensor, dampness sensor, GSM (Worldwide Framework for Portable) Speak with the controller and controlling all parameters for process necessity.

In industry programmed observing framework go about as an extremely vital capacity is to rise the assembling of the framework. In this wander I am offering a leniency for working room is the confined locale in the business and must important to give security. First initializing the administrator thumb picture and for whenever while administrator entering to in to the working room, thumb acknowledgment can done here once it matches with the first picture then as it were administrator window is open else it can't be open. In the event that the administrator window is opened then mechanical engineer can observing the mechanical parameters and set as far as possible, assuming any parameters crosses the points of confinement then administrator will receive data to controlling expert for the further activities with the assistance of GSM.

A few parameters that impacts to the industry is important to screen ,control and giving security counteractive action from the section of the unapproved individual in the confined region in the business, here I am thinking about administrator room is the confined region. For observing reason utilizing PC, it can likewise be made to assess and demonstrate the intelligible estimations of the sensors. This is reasonable for automated observing of the mechanical parameters as well as giving security in the business. This procedure canbe finished with an arrangement of sensors. Prepared the information signals, routinely recognizes the resultant readings of the parameters and if any parameter is crosses the limit, at that point the level of the parameters spoke to as sound-related and video frame. So an administrator will get the opportunity to be on comfortable terms with the parameters esteems crosses the limit which prompts risky to industry and in this manner he can go to if essential. Modified observing and giving security framework. The essential standard of this paper is to redesign of the administrator thumb picture and checking an assortment of parameters created by the business, digitize them and speak to them in an easy to look at frame

The open-source Arduino Programming (IDE) makes it simple to compose code and transfer it to the board. It keeps running on Windows, Macintosh OS X, and Linux. Nature is composed in Java and in view of handling and other open-source programming. This product can be utilized with any Arduino board. The Uno is an extraordinary decision for your first Arduino. It has all that you have to begin, and nothing you don't. It has 14 advanced information/yield pins (of which 6 can be utilized as PWM yields), 6 simple sources of info, a USB association, a power jack, a reset catch and then some. It contains everything expected to help the microcontroller; just associate it to a PC with a USB link or power it with an air conditioner to-DC connector or battery to begin. The Arduino

Coordinated Advancement Condition - or Arduino Programming (IDE) - contains a content manager for composing code, a message region, a content support, a toolbar with catches for basic capacities and a progression of menus. It associates with the Arduino and Genuine equipment to transfer programs and speak with them.

The Web of Things (IOT) is the system of physical gadgets, vehicles, home machines and different things, installed with hardware, programming, sensors, actuators, and availability which empower these articles to associate and trade information. Everything is extraordinarily identifiable through its implanted figuring framework however can between work inside the current Web foundation. Web of Things is utilized with IOT structures to deal with and collaborate with information and data. In the framework clients can enroll their sensors, make floods of information and process data. IOT are appropriate in different approaches of horticulture. Utilizations of IOT are Shrewd Urban communities, Savvy Condition, Brilliant Water, Keen Metering, Security and Crisis, Modern Control, Savvy Agribusiness, Home Robotization, e-Wellbeing and so on. 'Web of Things' depends on gadget which is fit for dissecting the detected data and after that transmitting it to the client.

The IOT enables articles to be detected or controlled remotely crosswise over existing system framework, making open doors for more straightforward incorporation of the physical world into PC based frameworks, and bringing about enhanced effectiveness, exactness and monetary advantage notwithstanding diminished human mediation. At the point when IOT is increased with sensors and actuators, the innovation turns into a case of the more broad class of digital physical frameworks, which likewise envelops advancements, for example, savvy networks, virtual power plants, brilliant homes, keen transportation and shrewd urban communities. These gadgets gather valuable information with the assistance of different existing advancements and afterward self-governing stream the information between different gadgets.

The Arduino Uno is a microcontroller board in light of the ATmega328 (datasheet). It has 14 advanced info/yield pins (of which 6 can be utilized as PWM yields), 6 simple information sources, a 16 MHz precious stone oscillator, a USB association, a power jack, an ICSP header, and a reset catch. It contains everything expected to help the microcontroller; just interface it to a PC with a USB link or power it with an air conditioner to-DC connector or battery to begin. The Uno varies from every first board in that it doesn't utilize the FTDIUSB-to-serial driver chip. Rather, it includes the Atmega8U2 customized as a USB-to-serial converter.

"uno" implies one in Italian and is named to check the up and coming arrival of arduino 1.0. the uno and adaptation 1.0 will be the reference renditions of arduino, advancing. The uno is the most recent in a progression of usb arduino sheets, and the reference demonstrates for the arduino stage; for an examination with past variants, see the file of arduino sheets.

III. ADVANTAGES, DISADVANTAGES, APPLICATIONS

- It diminishes the labor, it lessens risk, it controls consequently, it ceaselessly gives the present data about the business, gigantic blast can be stayed away from, it gives security.
- In some cases it may not give legitimate reaction because of manmade blunders,
- Crisis cautions when parameters surpasses their edge values, useful for climate checking frameworks

IV. RESULT

The security turns out to be essential undertaking in restricted zone of the business. In this paper giving security by acknowledgment thumb picture of the administrator. At first catch and spare the administrator picture in PC. While any individual is going into the confined territory (working room) of the business, catching of that entering individual thumb picture and redesign process doing here, if caught thumb picture isn't matches with the first thumb picture then administrator window isn't open. On the off chance that caught thumb picture is matches with the first picture at that point administrator window is opened.

At that point administrator can ready to going into the working room and he can ready to screen all the required parameters. Administrator can just set the edge esteems what he needs. With the greatest offices, administrator can ready to see all the required information stream programming source code. Administrator is observing all the constant variable mechanical parameters and if any required parameter is crosses as far as possible then administrator can ready to show the visual message in fluid precious stone show and furthermore giving capable of being heard cautions to the administrator. On the off chance that the administrator is outside of the working room, one endorser character module(SIM card) is embedded in GSM module, if any dangerous parameters crosses as far as possible then GSM sends ready message to the administrator through the worldwide framework for versatile communication(GSM).Observing modern parameters and furnishing security has actualized adequately with the assistance of IoT and remote correspondence has been

accomplished with a Global System for Mobile Communication framework.

V. CONCLUSION

Can be utilized for home or mechanical security systems, This venture depicts an IOT (Web of Things) based reconfigurable brilliant WSN (Remote Sensor System) unit for modern wellbeing parameters observing. The framework can gather sensor information shrewdly. It was composed in light of utilization of remote correspondence. It is exceptionally reasonable for constant and compelling necessities of the rapid information procurement framework in IOT(Internet of Things) condition. The use of ARDUINO UNO enormously rearranges the outline of fringe circuit and makes the entire framework more adaptable and extensible. Diverse sorts of sensors can be utilized as long as they are associated with the framework. Principle outline technique for the reconfigurable keen sensor interface gadget is depicted in this undertaking. At long last, by taking mechanical security parameters observing in IOT condition for instance, we confirmed that the framework accomplished great impacts in down to earth application. By the by, many intriguing bearings are staying for additionally looks into in the zone of WSN in IOT(Internet of Things) condition.

VI. FUTURE EXTENSION:

This paper speaks to the primary level of security i.e. Biometric Module, for facilitate change of security utilize IRIS acknowledgment, Face acknowledgment and so on. For this situation, observing and controlling parameters in synthetic Industry. This model can likewise be actualized in different ventures like material businesses where they have diverse parameters.

REFERENCES

- [1] S. Li, L. Xu, X. Wang, and J. Wang, "Integration of hybrid wireless networks in cloud services oriented enterprise information systems," *Enterp. Inf. Syst.*, vol. 6, no. 2, pp. 165–187, 2012.
- [2] Q. Li, Z. Wang, W. Li, J. Li, C. Wang, and R. Du, "Applications integration in a hybrid cloud computing environment: Modelling and platform," *Enterp. Inf. Syst.*, vol. 7, no. 3, pp. 237–271, 2013.
- [3] J. Manyika; M, Chui et. al, "Disruptive technologies: Advantages that will transform life, business and the global economy", May, 2013.
- [4] K. Ashton, "That 'Internet of Things' Thing", *RFID Journal*, 22 June, 2009.

- [5] T. Goetz, "Harnessing the Power of Feedback Loops", *Wired magazine*, 19 June 2011.
- [6] Dr.B.Ramamurthy, S.Bhargavi, Dr.R.ShashiKumar," Development of a Low-Cost GSM SMS-Based Humidity Remote Monitoring and Control system for Industrial Applications". (*IJACSA*) *International Journal of Advanced Computer Science and Applications*, Vol. 1, No. 4, October 2010.
- [7] SIM 900 –RS232 GSM/GPRS Modem User Manual. <http://www.rhydolabz.com>.
- [8] S.R. DEB (2013), "Robotics Technology and Flexible Automation", Tata McGraw Hill Pvt. Ltd., New Delhi.