

Experimental Investigation of Heat Transfer Enhancement in Flat Plate With Wavy Delta Winglet in Inline & Staggered Arrangement

Tushar Pendharkar¹, Bhushan Rane²

^{1,2}Dept of Mechanical Engineering

^{1,2}D Y Patil School of engineering Academy, Ambi, Pune

Abstract- Vortex generators are important heat transfer enhancers utilized now days to improve the performance of heat sinks. Wavy delta winglet is a novel vortex generator chosen for this study. In this study, experimental data for local heat transfer coefficients are presented for a plate with square cross section and wavy delta winglet vortex generators. Experiments are conducted to access turbulent forced convection heat transfer for air flow through a over a flat plate fitted with wavy delta winglet. Two arrangement namely in-line and staggered arrays, are checked. The flow rate is in terms Reynolds number based on hydraulic diameter of channel in range of 7000 to 24500. The experimental result shows a significant effect of presence of Wavy winglet on heat transfer rate over smooth flat plate. The inline arrangement observed to be provides higher heat than staggered one for a similar mass flow rate at higher Reynolds number.

Keywords- Wavy Delta winglet, Flat plate, Heat Transfer coefficient, Nusselt Number, Reynolds Number, Heat transfer Enhancement.

I. INTRODUCTION

Heat transfer enhancement is nothing but the process of increasing the effectiveness of heat exchangers. Increase of effectiveness can be achieved when the heat transfer power of a exchanger is increased or when the pressure losses by the device are reduced. Many techniques can be applied to this effect, including generating strong secondary flows or increasing boundary layer turbulence. As per knowledge, the technique of heat transfer enhancement could be one of the following

- (1) Use of a secondary heat transfer surface.
- (2) Disruption of the laminar sub-layer in the turbulent boundary layer.
- (3) Disruption of the unenhanced fluid velocity.
- (4) Enhancing effective thermal conductivity of the fluid under static conditions.
- (5) Increasing the order of the fluid molecules.

- (6) Promoting flow attachment/reattachment.
- (7) Introducing secondary flows.
- (8) Enhancing effective thermal conductivity of the fluid under dynamic conditions.
- (9) allowing delay the boundary layer development.
- (10) Modification of radiative property of the convective medium.
- (11) improving boundary-layer separation.
- (12) Re-distribution of the flow.
- (13) Thermal dispersion.
- (14) Increasing the difference between the fluid and surface temperatures.
- (15) Increasing the thermal conductivity of the solid phase using special nanotechnology fabrications.
- (16) Increasing fluid flow rate passively.

These methods include raising/increasing the surface area in contact with the fluid to be cooled or heated by using fins, intentionally promoting turbulence in the wall zone employing surface roughness and tall/short fins, and inducing secondary flows by creating swirls through the use of spiral/helical fin type and twisted tapes. This result into increase the effective flow length of the fluid through the tube, which not only increases heat transfer but also the pressure drop. For internal helical fins however, the effect of swirls tends to decrease or vanish all together at higher helix angles since the fluid flow then simply passes axially over the fins. On the other hand, for twisted tape inserts, the main contribution to the heat transfer augmentation is due to the effect of the induced swirl. Due to the formation of drag and increased turbulence caused by the disruption, the pressure drop with flow inside an enhanced tube or over walls always exceeds that obtained with a plain tube for the same length, flow rate, and diameter. The various shapes/ geometries used for the purpose of generating the swirl as discussed are broadly known as Vortex Generators. Vortex generator is a kind of passive heat transfer enhancing device which are attached to the fin surfaces or duct walls and protrudes into the flow path at particular angle of attack to the flow direction. It can be attached or stamped or punched out of surface of fin.

Using VGs, the fluid flow can be strongly disturbed because of the swirling effect flow when fluid flows over it. The vortex generator not only disrupts the growth of the boundary layer, disturbs the flow field, but also makes fluid swirl and causes a heavy exchange of core and wall fluid, resulting into the enhancement of heat transfer.

This paper is mainly based on the study conducted and under research for heat transfer enhancement with the use of vortex generator. There are types of vortex generators under study based on their novelty in geometrical design. Author here compared the performance of wavy delta winglet in different arrangement by means of experimental investigation.

II. LITERATURE REVIEW

In 1995, A. M. Jacobi & M. C. Gentry[1] had published a report on Heat Transfer enhancement on a Flat Plate using Delta-Wing Vortex Generators. For optimum configurations, a maximum average heat transfer enhancement of 42.3 percent was realized at $V = 0.75\text{m/s}$. The maximum average heat transfer enhancement was 43.0 percent at $V = 1.0\text{ m/s}$, and 41.0 percent at $V = 1.25\text{m/s}$. Further for pressure drop penalty they conclude that the ratio of Den/Do (drop enhanced Vs drop original) increases with wing aspect ratio, wing angle of attack and Reynolds number.

There are further studies are done for heat transfer enhancement using vortex generator. Kai Shing yang et al[2], conducted an experimental investigation of air cooling thermal module using various enhancements at low Reynolds number region. The experiment basically related to flat plate heat sinks with various type of vortex generators as indicated in figure below

The above heat samples was divided into four categories for understanding as

Type I: Plate fin heat sink featuring heat transfer improvement from increasing heat dissipate surface. Generally, the general heat transfer augmentation is via smaller fin spacing to accommodate more fin surface.

Type II: Heat sink with interrupted fin geometry

Type III: Heat sink with dense vortex generator. The general arrangement is using inline or staggered layout such as semi-circular, delta and dimple vortex generator.

Type IV: Heat sink with loose vortex generator: The enhancements of this category are still vortex generators or dimple/protrusion structure but with sparse arrangement of vortex generator.

As per the observation of their experimental study, the heat transfer performance is strongly related to the arrangement of enhancements. The densely arranged and interruptedly arranged vortex generator configurations normally results into more pressure drop penalty than improvements of heat transfer. This is particularly noted when operated at a lower frontal velocity. Actually the plain fin geometry outperforms most of the enhanced fin patterns such as of Type II and Type III at the fully developed region. This is because a close spacing results in prevention of the formation of vortex, and the presence of interrupted surface may also suffer from the degradation by constriction of conduction path. The results suggest that the vortex generators operated at a higher frontal velocity is more beneficial than that of plain fin geometry. Also the triangular attack vortex generator (delta winglet) is regarded as the optimum enhancement design for it could reduce 12–15% surface area at a frontal velocity around 3–5 m/s.

Heat sink	Nomenclature	Side view	Dimension	Photos of test sample
(a) Plate	-		-	
(b) Delta VG			-	
(c) Delta VG+Plate			-	
(d) Semi-circular VG			-	
(e) Triangular VG				
(f) Triangular Attack VG				
(g) Dimple VG				
(h) Two Groups Dimple VG				

Fig 1 Test samples for heat sink enhancement study[2]

Heat transfer enhancement with vortex generator is not only studies limited for flat plate but also for tube bank heat exchangers. M. S. Kamel[3] had presented the review paper and concluded vortex generator technique is one of the promising approaches of heat transfer enhancement. This is further numerically investigated by A. K. O. Albdoor [5]. The effects of three shapes of winglets is looked at (airfoil, rectangle and triangle) with different angles of attack (30 and 45) has been investigated on average heat transfer (Nu), friction coefficient and pressure drop. The conclusion was there is an effect for using winglet pairs on heat transfer, friction coefficient and pressure drop. Also, heat transfer depends on the shape, angle of attack of winglet. The triangle is the best shape for enhancing heat transfer and ($\alpha = 45$) is the best angle of attack for enhancing heat transfer.

N. C. Maniar[6] has checked the heat transfer enhancement using vortex generator geometric model (such as delta wing trapezoidal delta wing, delta winglet pair) in rectangular channel. His conclusions were the average surface Nusselt number ratio for a delta wing at attack angles of 30° and 45° shows that the heat transfer enhancement takes place to some extent and a higher attack angle produces higher heat augmentation but at the cost of pressure loss. It is also seen that the pressure loss is greater at higher attack angles. Thus the overall performance evaluation parameter goes below one. Hence, the delta wings are seldom used in heat exchangers. The main use of delta wings is in cases where one needs high average surface Nusselt number ratio and pressure loss is no concern. The low production, operating and manufacturing cost also add to the advantages of using delta wings.

The average surface Nusselt number ratio for a trapezoidal delta wing is much higher than that of delta wing at the same attack angles and same chord length of the wing. The only advantage is that the trapezoidal wing has a sharp leading edge which helps in the early generation of primary vortices and, thus, has higher average surface Nusselt number than the delta wing. The friction factor in this case too depends on the attack angle and, hence, higher attack angles produce higher pressure losses. It is seen that the performance evaluation parameter in trapezoidal wing is less than one but greater than that of delta wing. Despite this, the trapezoidal wing is not preferred over delta wing because of its unusual structure and cost of manufacturing.

The average surface Nusselt number ratio for a delta winglet pair is as high as that of a trapezoidal wing keeping the same chord length but the friction factor is very low and close to one, which is lower than the other two geometries. The Friction factor ratio is greater for higher attack angles. But, the performance evaluation factor is greater for the attack angle $= 30^\circ$ than that of $\beta = 45^\circ$. It is seen that the performance evaluation parameter is higher than one when $Re > 500$ for $\beta = 30^\circ$ while for $\beta = 45^\circ$ the Re should be around 1000. The delta winglet pairs are preferred over other geometries for obvious reasons and in case pressure loss is a concern.

The vortices generated in a delta winglet pair create more disturbances in the flow than in the delta wing or trapezoidal wing.

Boundary layer thinning occurs in all the geometries but is prominent and of higher order in a delta winglet pair and is visible downstream of the flow. Drag is formed in all geometries that are protruding when air flows through the channel but it is less in the case of a delta winglet pair. It is comparatively higher in the cases of delta wing and trapezoidal

wing. Also, greater angles of attack produce greater form drag and, thus, higher values of friction.

The heat enhancement in rectangular channel, in line with N. C. Maniar [6], was also checked numerically by N.K. Singh [8] for delta winglets with fixed angle of attack of 30° for Reynolds numbers 800, 1200, 1600, and 2000. The span wise averaged Nusselt number increases with use of vortex generators compared to the case without vortex generators considerably. An increasing the Reynolds number at a particular blade angle, results in an enhancement in the overall performance and span wise averaged Nusselt number was found to be greater at particular location for larger Reynolds number. The total heat flux from the bottom wall with vortex generators was found to be greater than that without vortex generators and the difference increases with increase in Reynolds number.

C. Supasri et al^[7] had checked the influence of vortex generator on air stream using smoke generator. The Reynolds number of air stream was between 30,000 and 80,000. It was found that the delta winglet at 30° degree of air stream contact angle having 20 mm fin height generates the maximum helical flow of air stream. However their analysis was purely on visual basis.

Against the traditional VG, Mehetmet Eren et al investigate the new longitudinal vortex generators[9]. A longitudinal vortex generators (LVGs) on heat transfer surface is one of the most widely employed heat transfer enhancement techniques. This technique is used for various kinds of thermal equipment such as internal and blade cooling of gas turbine, heat exchanger etc. A new punched rectangular vortex generators (PRVGs) and punched triangular vortex generators (PTVGs) are developed. The rectangular and triangular vortex generators were directly punched from the longitudinal winglet at attack angles of, 15° , 45° , and 75° respectively. Measurements are carried out for a rectangular channel of aspect ratio $AR=2$, winglet transverse pitch (S) to longitudinal winglet height (e) ratio of $S/e=0.59$, and a winglet height (e) to channel height (H) ratio of $e/H=0.8$. The Reynolds numbers considered for the channel flow case. The heat transfer results were obtained using an infrared thermal imaging technique. The heat transfer and pressure drop results of the vortex generators are compared with those of a smooth plate. With the PTVGs the best heat transfer performance was obtained.

A. T. Wijayanta et al. [16] conducted study on Heat transfer enhancement of internal flow by inserting punched delta winglet vortex generators with various attack angles. Heat transfer and the friction factor characteristics in the inner tube of a concentric double-tube heat exchanger inserted with

L-S and PDWVGs at three attack angles ($\alpha = 30^\circ, 50^\circ$ and 70°) for the turbulent regime, $Re = 5500-14500$ have been investigated. The presence of the PDWVGs with $\alpha = 70^\circ$ yields the higher heat transfer rate and friction factor up to 264 % and 11.87 times over the plain tube; 217 % and 3.42 times over the L-S. With increasing of the attack angle and Reynolds number, the heat transfer rate shows uptrend. The friction factor yields the downtrend with increasing Reynolds number and shows uptrend with increasing attack angle. For the PDWVGs with $\alpha = 70^\circ$, the maximum thermal performance factor was noted around 1.22. Empirical correlations in terms of Nusselt number, friction factor and thermal performance factor are in good agreement with measurement with the deviation under 10% for each.

A. S. Yadav et al.[12] studied the turbulence effect created by wire as roughness element. The turbulence created by small diameter of transverse wire ribs result in greater increase in heat transfer over the duct. However, higher friction losses noticed as a result of use of artificial roughness. The investigation had clearly demonstrates that average friction factor and the average Nusselt number increase with increase in the relative roughness height while giving opposite trend with increase in relative roughness pitch. The condition for optimum performance has been determined in term of thermal enhancement factor. A maximum value of thermal enhancement factor has been found to be 1.65 for the range of parameters investigated.

R. N. Sharma et al.[13] uses flag at vortex generator with gaps and challenges. The use of flexible plates or flags as vortex generators inside a channel was successfully demonstrated as an one of the alternative to heat transfer enhancement technique. Although flag dynamics is widely reported, the review reveals that this heat transfer technique is not widely explored, specifically on the heat transfer performance of flags. Extensive and intensive experimental results are lacking to validate numerical and theoretical predictions.

H.Y. Li et al.[15] checked the application of vortex generators to heat transfer enhancement of a pin-fin heat sink. the thermal-fluid characteristics of a pin-fin heat sink with delta winglet vortex generators in a cross flow are investigated experimentally and numerically. The effects of the Reynolds number of the flow, the angle of attack of the vortex generators, the shortest distance between the vortex generators, the distance between each vortex generator and the heat sink, the height of the vortex generators, and the configuration of the vortex generators on the performance of the heat sink are explored. The results show that the thermal resistance decreases as the Reynolds number increases, but

that the magnitude of the decrease tends to diminish with increasing Reynolds numbers. By considering the pressure difference and thermal resistance simultaneously, it was determined that an angle of attack of 30° is a better arrangement for the vortex generators. The thermal resistance produced with the shortest distance between the vortex generators equal to the length of the heat sink is lower than that produced with the shortest distance between the vortex generators greater than the length of the heat sink. The heat transfer of the heat sink is higher, when the vortex generators are installed against the middle of the heat sink, on both sides of it. Though increasing the height of the vortex generators can improvise the heat transfer rate, the pressure difference also increases. The thermal resistance of the heat sink with the vortex generators arranged in the common-flow-up configuration is lower than that of the heat sink with the vortex generators arranged in the common-flow-down configuration.

P. W. Deshmukh et al.[17] investigate Heat Transfer Enhancement in tubes for Laminar Flow using Curved type Delta Wing Vortex Generator Inserts. The thermo hydraulic performance of these inserts with different geometrical parameters viz. angle of attack (α), pitch to projected length ratio (p/pl) and circumferential contact length to tube inner diameter ratio (b/d) has studied. The local heat transfer measurements for both smooth and rough surface sides of the tube are reported with the tube Reynolds number (Re) varying between 250 to 1500. The average Nusselt number ratio with and without the insert (N_{ua}/N_{us}), at equal Reynolds number (Re) has found to be in the range of 5.0 to 15.0. The performance ratio, (N_{ua}/N_{uc}), based on equal pumping power and constant heat transfer area, has found to be in the range of 1.0 to 6.0.

M. Oneissi et al[14] checked novel design of delta winglet pair vortex generator for heat transfer enhancement. numerical simulations are conducted for the classical delta winglet pair (DWP) which is introduced as the reference case in there study. Then, an innovative VG configuration, named inclined projected winglet pair (IPWP), has examined which shows superior performance relative to the DWP. The IPWP exhibits similar heat transfer rates than that of the DWP but with lower penalty of pressure drop due to their special aerodynamic shape & design. The performance is analyzed based on the streamwise distribution of Nusselt number and friction coefficient criteria along with contribution of vorticity. Their study highlights the different mechanisms involved in the convective heat transfer intensification by generating multiple vortices using more aerodynamic VG shape while at the same time decreasing the pressure drop penalty.

At latest R. Maithani et al ^[10-11] studied heat transfer and friction factor characteristics of solar air heater using wavy type delta winglets. Their Concluding comments are: the relative longitudinal pitch inversely affects the Nusselt number. With increasing relative longitudinal pitch of wavy winglet, the Nusselt number decreases by incorporating all types of wavy winglets on the absorber plate i.e. it is least for 6 and most for relative longitudinal pitch of 3. For 5 number of waves the Nusselt number is found to be maximum. This pattern is reflected at all values of relative longitudinal pitch. The friction factor decreases with increasing Reynolds number for all types of winglets used at all relative longitudinal pitches. The friction factor was found to be least for relative longitudinal pitch of 6, followed by 5, 4 and maximum for 3. The five wave winglet pair at relative longitudinal pitch of 3 shows a maximum value of Nusselt number enhancement factor of around 3.2 over a smooth plate. For seven wave winglet pairs at relative longitudinal pitch of 3 the friction factor enhancement value 10.9 was noted as maximum. At relative longitudinal pitch of 3, the thermo-hydraulic performance of around 2.1 was obtained, at Reynolds number of 4000 and using five-wave winglet arrangement.

OVERALL ANALYSIS:

Heat transfer enhancement (even considering vortex generators only) is overall very vast topic for study and it gives great opportunities to research same things with different angle of perception with different results based on application. Above literature survey conclude that the vortex generators especially delta wing delta winglets, PLGVs holds great promise for heat transfer enhancement and further future studies.

Now here with reference to latest investigation by R. Maithani et al [9] over wavy delta winglet, the wavy delta winglet reflects the good improvement in heat transfer enhancement particularly for solar air heater application analysis. They have checked the effect of wavy winglet with different number of waves and different longitudinal pitch. However the same can be explored for different arrangements (staggered & inline) of wavy winglet with particular aspect ratio in general over flat plate. Based on it, we can check the performance of wave wavy delta winglets with respect to Nusselt number & Effectiveness ratio for heat transfer enhancement.

III. EXPERIMENTATION

Experimental set up having an insulated rectangular duct, flat plate, blower which is used to regulate mass flow rate of air. An insulated rectangular acrylic duct is used in

which test section i.e. flat plate is accommodate. A heater is placed beneath the aluminum plate for heating of flat plate. Temperature sensors along with digital temperature indicators are used to measure inlet and outlet temperature of air. Thermocouples also measure the surface temperature of flat plate. The schematic diagram of the experimental set up is as shown in fig.1 the air is taken from atmosphere pressurizes when it passes through blower, the pressurized air then flows through a flow control valve where flow is regulated. The velocity of air is measured at exit of rectangular duct by anemometer. The air is fed to rectangular duct by means of blower, where it absorbs the heat from the flat plate which in turn receives the heat from heater which is kept at beneath of flat plate. The heated air then taken out from the outlet of rectangular duct.

Rectangular Duct:

An insulated rectangular duct of square cross section area

- Material of duct= Acrylic fiber
- Width of duct = 150mm
- Height of duct = 100mm

Flat plate:

- Material = Aluminum
- Width = 150mm
- Height = 150mm
- Thickness = 10mm

Wavy Delta winglet:

- Material = Aluminum
- thickness = 0.67mm
- Height = 12.5mm
- Number of waves=3
- Angle of attack $\alpha=60^\circ$

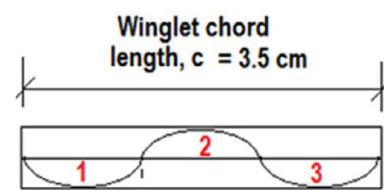

A. Experimental Set up

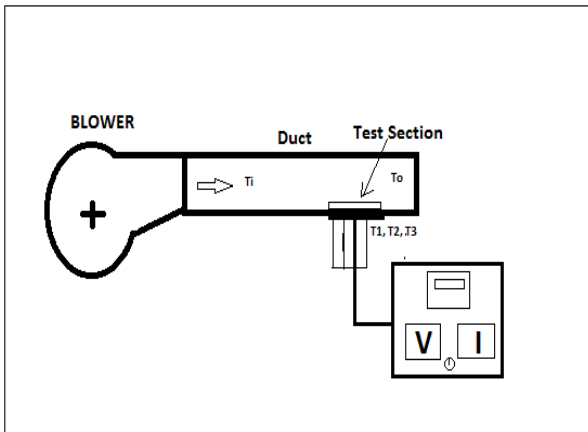

Fig.1.Schematic of Experimental Set up

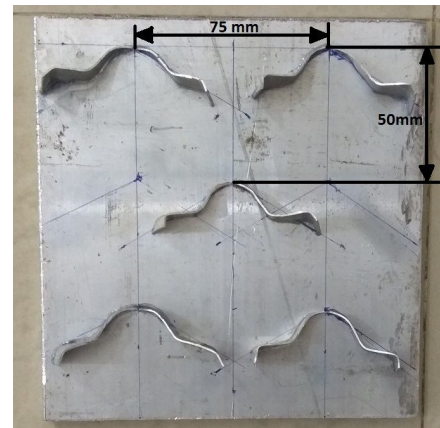

Fig.4 Staggered wavy delta winglet on flat plate



Fig.2.Actual of Experimental Set up

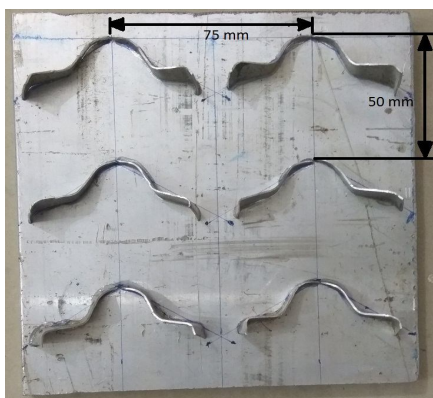

Fig.3.Inline wavy delta winglet on flat plate

IV. TEST METHODOLOGY

A) Arrangement of Wavy winglet – The experiments were carried out using Aluminum plate having smooth i.e flat plate, In-line and staggered arrangement of wavy delta winglet.

B) Various flow conditions – characterize by Reynolds number ($7000 \leq Re \leq 24500$).

Table 1.Flow Conditions

Reynolds Number	Velocity, m/s
7000	1.0
14000	2.0
21000	3.0
24500	3.5

The experiment was conducted for various operating conditions to develop the complete understanding of the heat transfer mechanism. The flow condition ranging from $Re=7,000$ to $Re = 24,500$ was considered. The velocity of air is noted by means of hot wire anemometer. Since area of duct & velocity are available we can calculate the flow through the duct.

C) Heat source -

Constant heat supply of $\sim 50W$ ($V \cdot I = 50W$) is provided at beneath of flat plate & measured using Voltmeter and Ammeter.

The test specimen i.e. flat plat was placed in rectangular duct and blower operation started. Since air leakage in or out of duct can affect the results, the leakage of air is checked and arrested. The thermal sensors are then placed at their decided location over the plate to measure the surface temperatures. Further two sensors are placed in air stream to measure inlet air & outlet air temperature which in

turn is the measure of heat gain by air. At first, in control panel adjust voltage and current that supply const. heat source (thermal energy) flat plate then the blower is turn on to supply the air. From the anemometer readings the stability of flow is monitored. Once flow stability is achieved. Now, the temperature from thermo couples T-1 to T-5 is to be monitored & noted for the steady state condition.

The set up is then allowed to back to normal condition & the smooth plate section is then replaced with plate having inline wavy winglet arrangement. Same method as mentioned above is then repeated for inline arrangement & readings are noted. After completion of procedure for inline arrangement, same procedure is then repeated for test specimen with staggered Wavy arrangement. The data thus collected is reduced with the use of following formulas to conclude to results.

V. DATA REDUCTION

For data reductions following are the steps required:

1. Heat absorb by air = $Q = m \text{ cp } \Delta T$ Watt
2. Mass flow rate $m = \rho A v$
3. Change in temperature of air $\Delta T = T_o - T_i$ K
4. Temperature of air = $T_m = (T_i + T_o) / 2$ K
5. Heat absorb by air = $Q = m \text{ cp } \Delta T = h A \Delta T_s$
6. $\Delta T_s = (T_s - T_m)$
7. Power supply = $V \times I$
8. $h = Q / (A \Delta T_s)$ $W / m^2 K$
9. $Re = \rho V D_h / \mu$
10. $D_h = 2 \times \text{Length} \times \text{Height} / (\text{Length} + \text{Height})$
11. $Nu = h \times D_h / k$ (here k is thermal conductivity)
12. Enhancement Ratio is calculated by taking the ratio of Nusselt number of modified plate i.e. wavy winglet inline and wavy winglet staggered to Nusselt number of smooth plate

$$E_{Nu} = \frac{Nu_{modified}}{Nu_{smooth}}$$

VI. RESULTS AND DISCUSSION

With the data reduced with above relations, we arrives to the results as mention here. Figure 4 shows variation of heat transfer coefficient to Reynolds Number. This graph indicates that there is higher heat transfer coefficient for inline than smooth plate. It varies from 85% to 277 % than smooth plate.

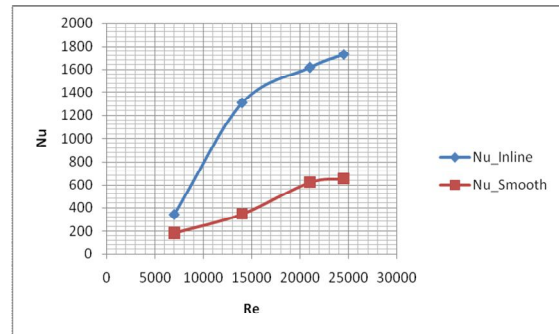

Fig. 4. Variation of Nusselt number to Reynolds Number.

Figure 5 shows variation of Nusselt to Reynolds Number. This graph indicates that there is higher heat transfer enhancement for staggered arrangement than smooth plate. It varies from 98% to 239 % than smooth plate.

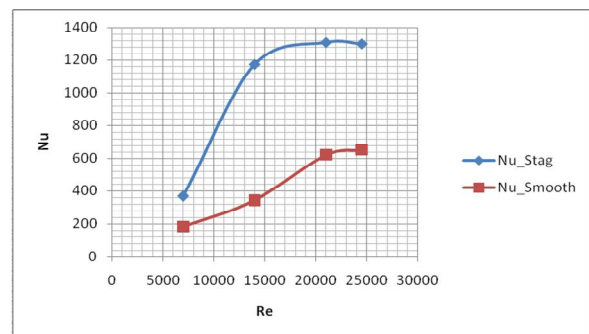

Fig. 5 Variation of Nusselt Number to Reynolds Number.

Figure 6 shows variation of Nusselt to Reynolds Number. This graph indicates that there is higher heat transfer enhancement for inline arrangement than staggered arrangement over plate at higher Reynolds number. It varies from 11% to 33 % than staggered. However at lower Reynolds number the heat transfer enhancement is observed improved for staggered arrangement.

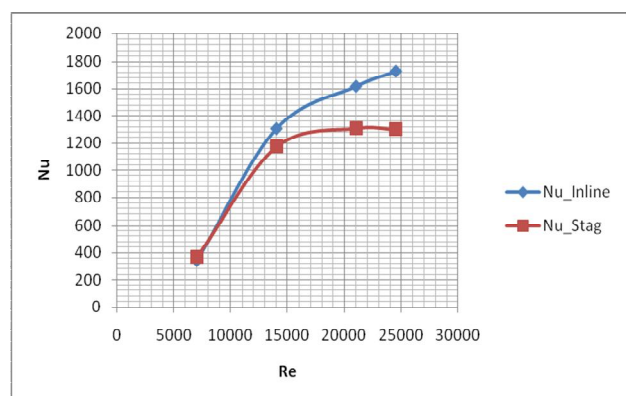

Fig. 6 Variation of Nusselt Number to Reynolds Number.

Figure 7 shows variation of enhancement factor to Reynolds Number. This graph indicates that there is higher

enhancement factor for inline wavy winglet than staggered. If we compared inline wavy winglet arrangement to smooth plate the enhancement factor varies from 1.85 to 3.77 whereas for staggered to smooth plate it varies from 1.98 to 3.4.

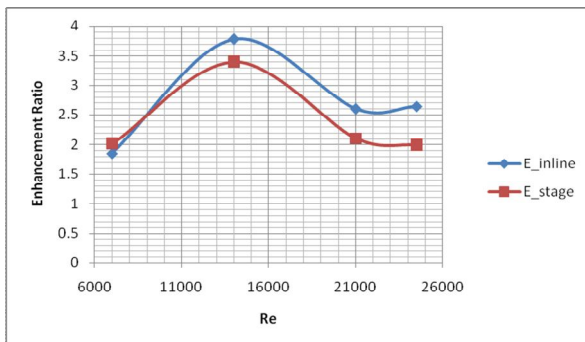

Fig.7 Variation of enhancement factor to Reynolds Number.

Hence from above graphs we can conclude that inline wavy winglet arrangement gives higher heat transfer enhancement than staggered arrangement and smooth plate at higher Reynolds number. So such type of configuration one can use for different cooling system such as electronics cooling system.

VII. CONCLUSION

Experimental investigation on inline and staggered wavy winglet are compared with smooth plate with Reynolds number from 7000-24500. Following are the conclusion of this work.

1. Heat transfer coefficient varies from 85% to 277% than smooth plate. If we compared inline to staggered there is increase in heat transfer coefficient from 11% to 33% increasing with Reynolds number
2. It's observed that at lower Reynolds numbers the performance of staggered arrangement matched or slightly improved than inline arrangement. Probably the staggered arrangement will be more effective at lower Reynolds number which further scope for study.
3. With enhancement ratio from 1.85 to 3.77, Wavy delta winglets holds great promise for heat transfer enhancement for heat sink application and further future studies for electronic cooling.

REFERENCES

[1] M. C. Gentry and A. M. Jacobi, Heat Transfer Enhancement on a Flat Plate Using Delta-Wing Vortex Generators, Air Conditioning and Refrigeration Center University of Illinois. Mechanical & Industrial Engineering Dept., ACRC TR-82, July 1995

- [2] K. Yang, S. Li, I. Y. Chen, K-H Chien, R. Huc, C. Wang., An experimental investigation of air cooling thermal module using various enhancements at low Reynolds number region; International Journal of Heat and Mass Transfer 53 (2010); pp 5676-5681
- [3] M. S. Kamel; Heat Transfer Enhancement and Fluid Flow across Tube Banks Heat Exchanger with Passive Control Technique by Using Vortex Generator (A Review); International Journal of Science and Research (IJSR) ISSN (Online): 2319-7064 Impact Factor (2012): 3.358, pp 363-367
- [4] A. K. O. Albdour, Numerical Study of Fluid Flow and Heat Transfer over a Circular Tubes Bank of Heat Exchanger with Different Shapes of Vortex Generator International Journal of Science and Research (IJSR) ISSN (Online): 2319-7064 Impact Factor (2012): 3.358, pp 2032-2040
- [5] N. C. Maniar, Heat transfer enhancement in a rectangular channel using vortex generator in a laminar flow, for The University of Texas at Arlington, Dec 2012
- [6] Chakkapong Supasri, Tanongkiat Kiatsirirot, Atipoang Nuntaphan, Influence of Vortex Generator on Flow Behavior of Air Stream, International Journal of Mechanical, Aerospace, Industrial and Mechatronics Engineering Vol:7, No:9, 2013, pp 781-784.
- [7] N. K. Singh, "Numerical Investigation of Heat Transfer in a Channel with Delta Winglet Vortex Generators at Different Reynolds Numbers International Journal of Mechanical, Aerospace, Industrial, Mechatronic and Manufacturing Engineering Vol:7, No:12, 2013 pp 2614-2619
- [8] M. Eren, S. Caliskan, Heat Transfer Enhancement in a Channel with New Longitudinal Vortex Generators, International Scientific Journal Environmental Science :2015
- [9] R. Maithani, A. human Silori, J. Rana, S. Chamoli, Numerical analysis of heat transfer and fluid flow of a wavy delta winglets in a rectangular duct, Elsevier: Thermal Science and Engineering Progress 2 (2017), pp 15-25
- [10] J.S. Sawhney, R. Maithani, S. Chamoli, Experimental investigation of heat transfer and friction factor characteristics of solar air heater using wavy delta winglets, Elsevier: Applied Thermal Engineering 117 (2017), pp 740-751
- [11] S. B. Kharge, N.C.Ghugre, V.S. Daund, Experimentation using delta winglet type vortex generator attached on tube surface of tube in tube heat exchanger for heat transfer augmentation, International Journal of Current Engineering and Technology E-ISSN 2277 - 4106, P-ISSN 2347 - 5161, pp 398-402

- [12] A. S. Yadav, J.L. Bhagoria, A CFD (computational fluid dynamics) based heat transfer and fluid flow analysis of a solar air heater provided with circular transverse wire rib roughness on the absorber plate, Elsevier: Energy 55 (2013) 1127-1142, pp 1127-1142
- [13] R. Kristoffer B. Gallegos, R. N. Sharma, Flags as vortex generators for heat transfer enhancement: Gaps and challenges, Elsevier: Renewable and Sustainable Energy Reviews 76 (2017) 950–962, Application of vortex generators to heat transfer enhancement of a pin-fin heat sink, Elsevier: International Journal of Heat and Mass Transfer 112 (2017) 940–949
- [14] M. Oneissi, C. Habchi, S. Russeil, D. Bougeard ,T. Lemenand, Novel design of delta winglet pair vortex generator for heat transfer enhancement, Elsevier: International Journal of Thermal Sciences 109 (2016) 1e9
- [15] H.Y. Li, W. R. Liao, T.-Y. Li, Y. Chang, Application of vortex generators to heat transfer enhancement of a pin-fin heat sink, Elsevier: International Journal of Heat and Mass Transfer 112 (2017),pp 940–949
- [16] A. T. Wijayanta, T. Istanto, K. Kariya, A. Miyara, Heat transfer enhancement of internal flow by inserting punched delta winglet vortex generators with various attack angles, Experimental Thermal and Fluid Science (2017), pp 1-37
- [17] P.W. Deshmukh, S.V. Prabhu, R.P. Vedula, Heat Transfer Enhancement for Laminar Flow in Tubes Using Curved Delta Wing Vortex Generator Inserts, Elsevier: Applied Thermal Engineering (2016), pp 1-32