

Heat Transfer Enhancement In Gas Turbine U-Shaped Channel With 60° Ribs, Under Rotational Effect

Mohammed Gouse¹, Omprakash Hebbal²

^{1,2}Dept of Mechanical Engineering

²Professor, Dept of Mechanical Engineering

^{1,2}P.D. A College of Engineering, Kalaburagi, Karnataka

Abstract- Gas Turbines are designed to continuously and efficiently generate useful power from fuel energy and are developed into very reliable high performance engines. Nowadays gas turbines have been put to use in various fields like, power plants, marine industries as well as for industrial propulsion. For high thermal efficiency advanced gas turbines use high temperature at the entry of the turbine. Therefore, for the purpose of increasing thermal efficiency of the turbines, it is important to design effective cooling schemes. The current turbine inlet temperature in advanced gas turbines is much higher than the melting point of the blade material. As a result a varied range of cooling techniques are used to cool the blade to maintain normal operation of the turbine. An attempt has been made to computationally analyses the effects rib tabulators cooling, wherein the cooling effects of air flow through a ribs in internal passage of blade has been simulated using ANSYS-FLUENT. The three cases has been studied, ribs are designed 60° with different arrangements namely opposite ribs, intercross ribs and parallel ribs. It is found that, in parallel ribs heat transfer is maximum compared to opposite ribs and intercross ribs, due to which life of these blades are prolonged.

suitable configuration which is effective in limiting the maximum wall temperatures below a certain value for thermal conditions. These include the heat transfer coefficient and the gas temperature, using the ANSYS FLUENT CFD.

II. LITRATURE SURVEY

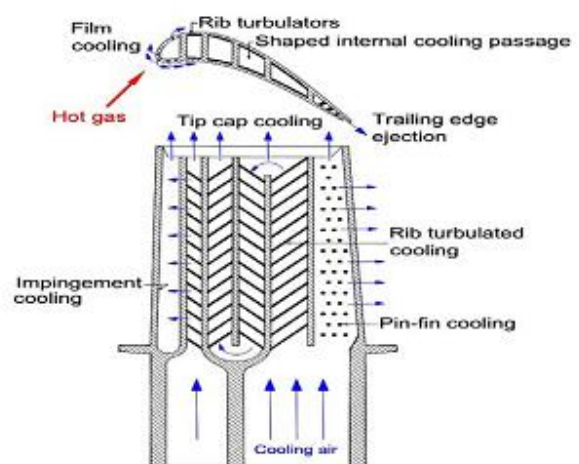

Fig 1 Blade Cooling, Han et al [3].

Keywords- Cfd, U shaped rib turbulators ,Nusselt Number

I. INTRODUCTION

Blade cooling: Turbine blades are one of the most important components in a gas turbine. The most effective way of maintaining high operating temperature making use of the available material. Blade cooling which maintain the temperature of the blade at a value low enough to preserve the desired material properties. If a turbine blade is heated rapidly to a high temperature it causes uneven temperature distribution and a result of this severe thermal stresses are developed within the blade. To avoid this problem during operation the blades should to be cooled at desired temperature to achieve higher thermal efficiency. [1]

The main aim of this current work is to design to design a cooling configuration for the leading edge using internal convection only. The heat transfer technique to find

Rib tabulators are the most frequently used method to enhance the heat transfer in the internal serpentine cooling passages. The rib turbulence promotes are typically cast on walls of the cooling passage. Heat that conducts from the pressure and suction surfaces through the blade walls is transferred to the coolant passing internally through the blade. The heat transfer performance of the ribbed channel depends on the channel aspect ratio, the rib configurations, and the Reynolds number of the coolant flow [2].

Han et al 1980 [3] has conducted his works in (cooling of gas turbine blades) and demonstrated schematic fig 2.1 of typical techniques for turbine blade cooling process. To increase the heat transfer performance of coolant passages which has been investigated and discussions of aspect ratio, channel shape, Reynolds number, rib configurations. He investigated the ribs-tabulators at different position that is 90° , 45° parallel, 60° continuous, broken ribs, V-shaped ribs at 45° v-shaped broken rib. The results were higher heat transfer in the

v-shaped 60° broken ribs, compare to other arrangements of ribs.

N. Kaewchoothong et al 2004 [4] has studied the flow and heat transfer characteristic in a rotating two pass square channel with ribbed walls, the testing fluid is air and Reynolds number is at 10000. He studied this characteristic in ansys fluent v15.0. The results show that ribbed walls enhance the heat transfer significantly, under rotating condition maximum heat transfer rate observed for rotation number of 0.4 and 10-20% higher heat transfer rate when compared with other rotation numbers.

Yaho-hseinliu 2010 [5] has studied the effect of high rotation number on heat transfer in a triangular channel with 45°, inverted 45°, and 90°. He studied the ribs under the different parameters are Reynolds number, rotation number. The Reynolds number varies from 10000-40000 and different rotating speed 0-400 rpm. The results were predicted in Nusslet number for both stationary and rotating speeds. The results for stationary condition, staggered 45° angled ribs show the highest heat transfer enhancement. The staggered 45° angled ribs and 90° ribs have the higher comparable heat transfer enhancement at rotating condition near the blade leading edge region. Zhongyang Shen et al 2014 [6] has the studied flow and heat transfer characteristics for U-shaped channel with 90° ribs that in internal cooling passage of turbine blade, the 90° parallel ribs are placed on rotating trailing surfaces. The rotation number varies from (0.2-1). The average Nusselt number of the whole channel is increased significantly due to the effect of rotation. As rotation number increases the effect on the heat transfer occurs.

Miuzurrehman et al 2016 [7] has studied heat transfer enhancement of trapezoidal channel with guided ribs in it. It has two pass channel with 180° bend. The ribs has placed at trapezoidal channel region at leading and trailing surface because the these regions face maximum temperature, the ribs that can increase walls heat transfer up to 40%, and all this is related to Reynolds number variation standard k-ε turbulence model was adopted to investigate the trapezoidal channel. The results were in the increase in Nusselt number with increase flow field in channel, the heat transfer is high there is low pressure drop.

Michael Göhring et al 2016 [8] has studied the cooling of gas turbine blade, the cases were stationary and rotating, smooth with ribbed two-pass cooling channels. The geometry of cooling passages was square type of channel with two pass, 180° bend and circular ribs were at inclined at 45°. The results were predicted the increase in heat transfer as increase in Reynolds number, as rotation number tends to

increase above the 0.36 has lower rate of heat transfer. The smooth channel has less heat transfer compared to rib in channel has high heat transfer rate.

III. METHODOLOGY

Introduction: The methodology of the modeling, meshing and analysis of the U-shaped channel internal passage of gas turbine blade. Rib tabulators are design in the blade internally on the leading surface. The ribs made internally at angled 60° with different configuration of ribs on the leading side of blade.

Geometry: CAD-Model was generated in SOLID WORKS V.18. The following are different arrangements of the ribs.

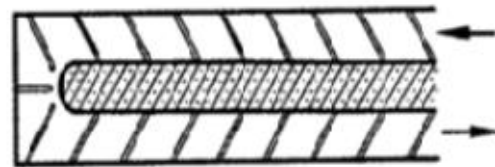

Fig 2 60° opposite ribs

The above figure 2 shows the channel with 60° parallel ribs, with 180° bend and additional rib 90° at the bend is designed, as case-1.

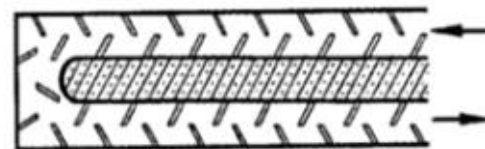

Fig 3 60° intercross ribs

The above figure 3 shows the channel with 60° intercross ribs, with 180° bend as case-2.

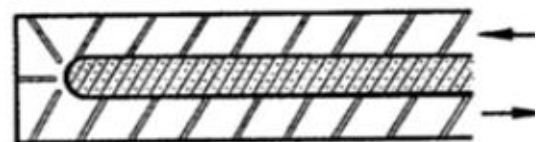

Fig 4 60° parallel ribs

The figure 4 shows the channel with 60° parallel ribs, with 180° bend and additional ribs 90° at the bend is designed at bend, as case-3.

The details of geometry:

Length of channel 0.3 m, Hydraulic diameter of channel is 0.03m, Rib-tabulators diameter has 3mm, Rib pitch is 0.03m, and Ribs angle 60°.

Computational domain:

The following are the fluid domain of different arrangements ribs tabulators:

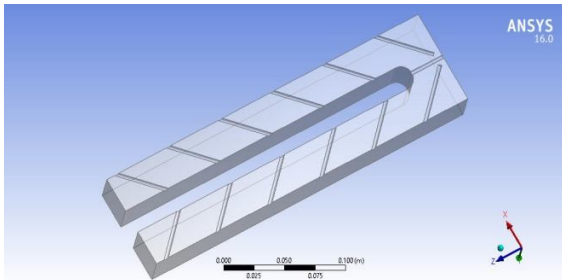

Fig 5 Computational domain of the Ribs with 60° rib

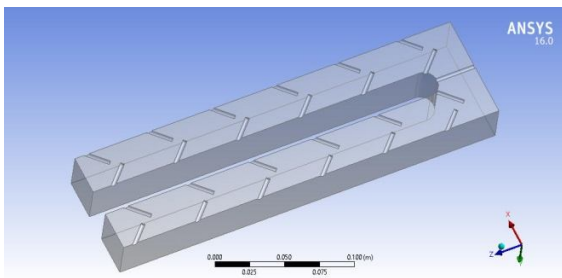

Fig 6 Computational domain of the ribs with 60° intercross ribs

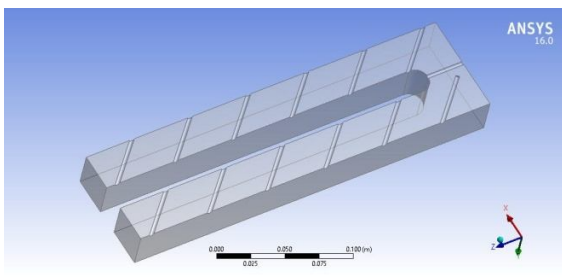

Fig 7 Computational domain of the ribs with 60° parallel rib

The domain of three cases are shown in figures 5, 6, and 7 with different arrangement of ribs in the channel. The ribs are arranged at angle of 60° in different manner i.e. parallel, opposite and intercross ribs.

Meshing

The geometry is imported into ANSYS Design Modeler and then meshed using ANSYS ICEM. A fine mesh

is generated near the ribs of the channel so as to capture the velocity variations due to turbulence. The mesh details are mentioned as below table1.

Table1 Mesh details

No of nodes	132794
Elements	691440
Min Size of element	0.000045533 m
Max size of element	0.009107 m

Setup

The problem is solved in the ANSYS FLUENT V16.0.

Boundary conditions

Table 2

Condition	Value
Intel temperature	298.5k
Inlet velocity of fluid	1m/s
Outlet pressure is maintained	1 atm
Heat flux on leading and trailing edge surface	250 W/m ²
Reynolds number	12500

Solution method

This problem is steady state, Energy equation is turned on, the turbulence was model k- ω with shear stress transport (SST) is applied. The wall treatment was done with standard wall functions.

Shear-stress transport (SST) transition model: The shear-stress transport (SST) k- ω turbulence model combines two models to better capture the flow in the regions ribbed surface. The transition SST model was developed aiming to model the transition from laminar to turbulent flow in shear layer. The full transition model is based on two transport equation, one for intermittency and one for the transition onset criteria [9]

- Scheme: SIMPLE.
- Gradient: Least Square Cell Based.
- Pressure: second order.
- Momentum: second order.

This problem is simulating heat transfer over ribbed surface. For the rotational orientation, the rotation axis is located at the centerline of channel inlet section. The rotating direction of the two-pass U-shaped channel is clockwise of x-

axis direction. For different rotation speed and rotation direction the rotation factor Ro is used to express a non-dimensional rotation speed which is defined by $Ro = (\omega * dh) / V$ where ω , dh and V indicate rotating angular speed, hydraulic diameter and channel inlet velocity respectively.

IV. RESULTS

In order to have a comprehensive understanding of the fluid flow and heat transfer in the ribbed surface. Different cases have investigated the average Nusselt number for different rotations, A number of trend graphs is drawn to show the variation of average Nusselt number with different rotation speeds

The validation shows the ribs at 90°.

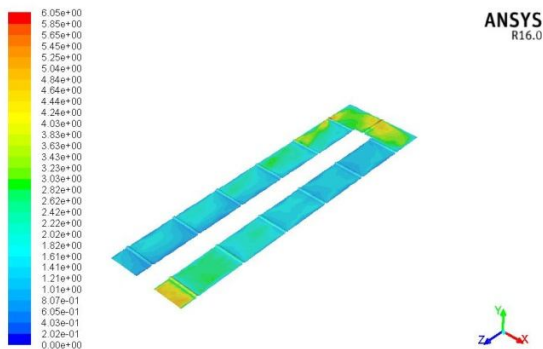

Figure 1.a show Nu/Nu0 for 0.2

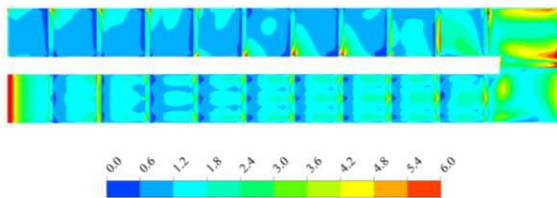

Fig 1.b validation Nu/Nu0 for Ro=0.2

Figure 4.1a shows the maximum Nusselt number for rotation 0.2 occurs at 180° bend which is 6.05. In figure 4.1b shows maximum Nusslet number at rotation 0.2 is 6.0, which is well comparable with results of author Zhongyang Shen [6]. Hence it is validated.

Case 1: Results with 60° opposite ribs

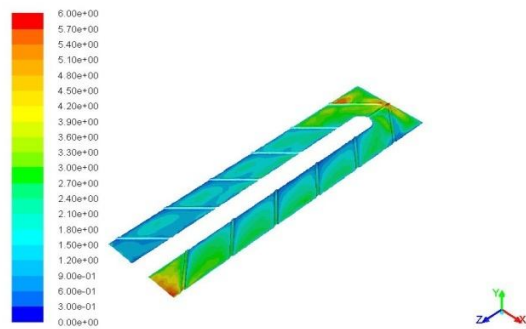

Fig 1.c Nu/Nu0 for Ro=0.2

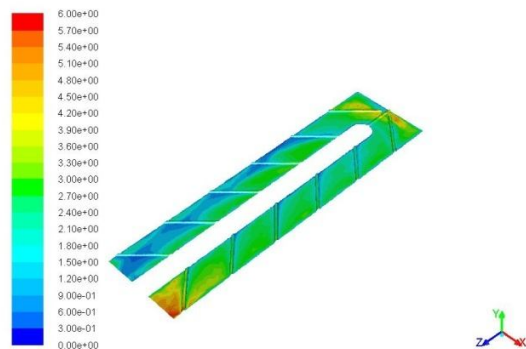

Fig 1.d Nu/Nu0 for Ro=0.4

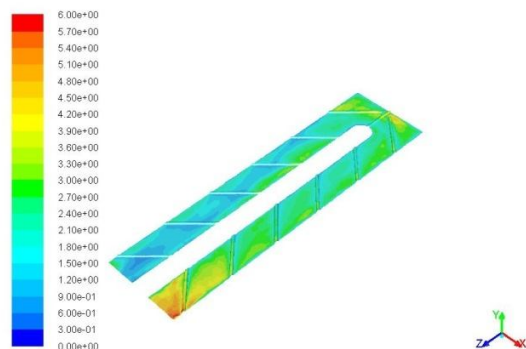

Fig 1.e Nu/Nu0 for Ro=0.6

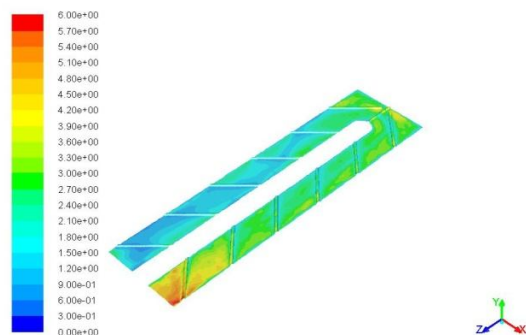

Fig 1.f Nu/Nu0 for Ro=0.8

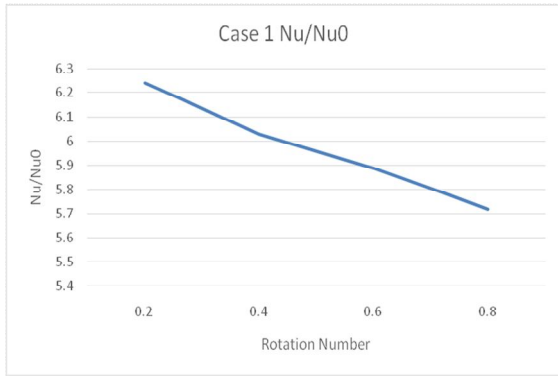

Fig 1.g Nu/Nu0 Vs Rotation number with 60° ribs

Figure 1.c, 1.d, 1.e and 1.f show the average Nusselt number for rotation 0.2, 0.4, 0.6 and 0.8 respectively at 60° opposite ribs. Figure 1.g shows the variation average Nusselt number for different rotation number. It can be seen that average Nusselt number reduces with increase in rotation speeds, since increase in the rotation increases Coriolis and centrifugal forces, which makes fluid flow in opposite direction.

Case 2: Results with 60° intercross ribs.

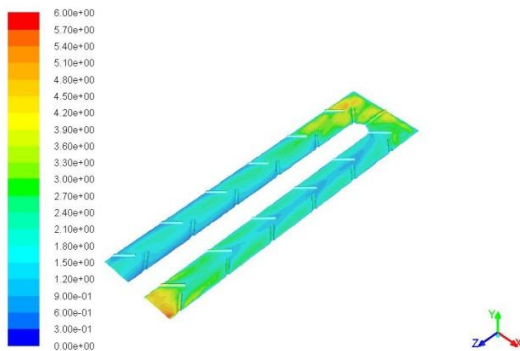

Fig 2.a Nu/Nu0 for Ro=0.2

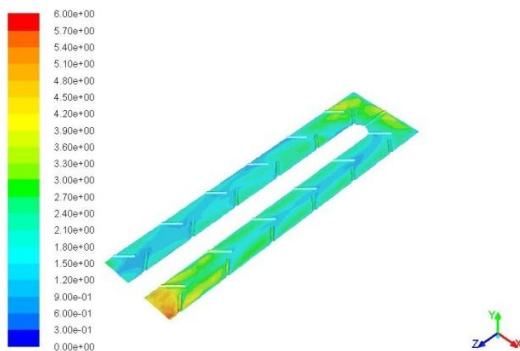

Fig 2.b Nu/Nu0 for Ro=0.4

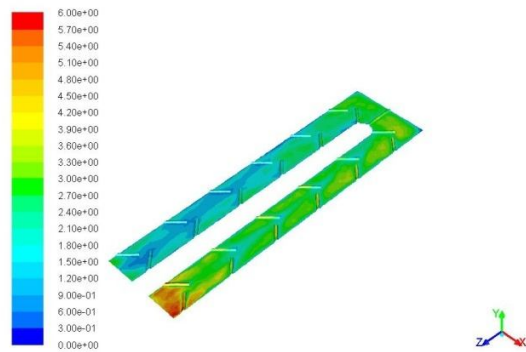

Fig 2.c Nu/Nu0 for Ro=0.6

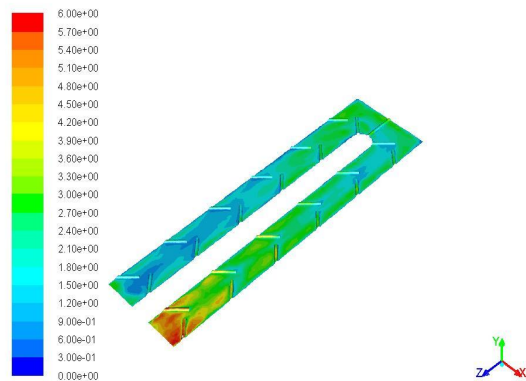

Fig 2.d Nu/Nu0 for Ro=0.8

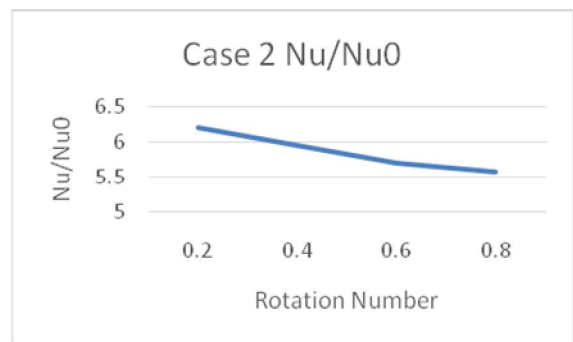

Fig 2.e Nu/Nu0 Vs Rotation number with 60° intercross ribs

Figure 2.a, 2.b, 2.c and 2.d show the average Nusselt number for rotation 0.2, 0.4, 0.6 and 0.8 respectively for 60° intercross ribs. Figure 2.e shows the average Nusselt number decrease from rotation 0.4 increase in the rotation number the average Nusselt number decreases. Since increase in rotation increases Coriolis and centrifugal forces, which affect the fluid flow.

Case 3: Results with 60° Parallel ribs

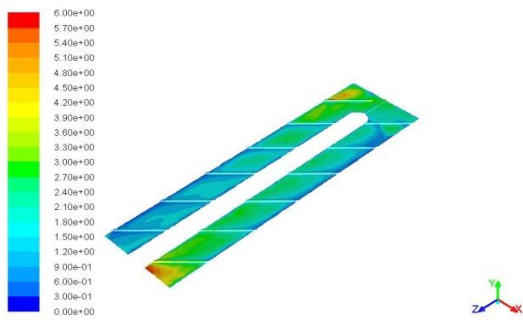

Fig 3.a Nu/Nu0 for Ro=0.2

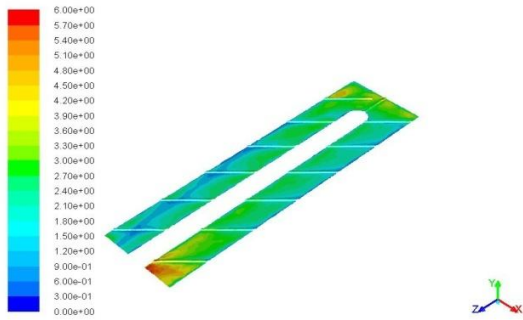

Fig 3.b Nu/Nu0 for Ro=0.4

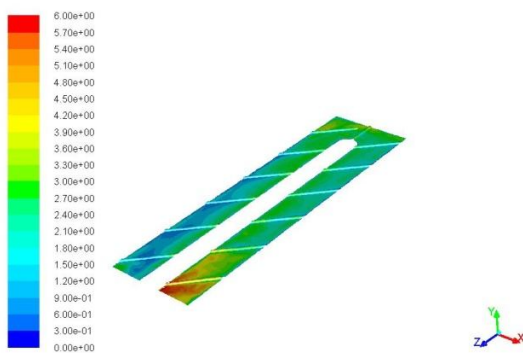

Fig 3.c Nu/Nu0 for Ro=0.8

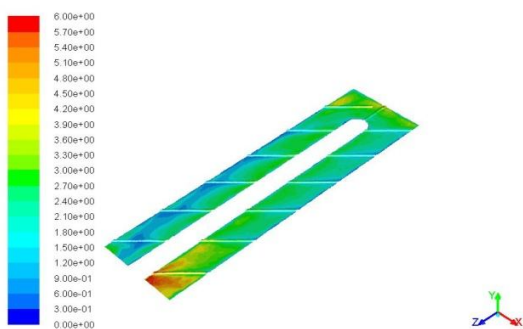

Fig 3.d Nu/Nu0 for Ro=0.6

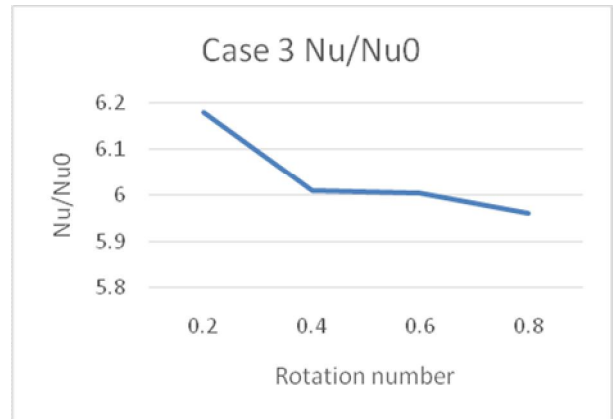

Fig 3.e Nu/Nu0 Vs Rotation number with 60° parallel ribs

Figure 3.a, 3.b, 3.c and 3.d show the average nusselt number for 0.2, 0.4, 0.6 and 0.8 respectively for 60° parallel ribs. The figure 3.e shows variation of average Nusselt number for different rotation number. It can observe that average Nusselt number reduces in the rotation speeds. Since increase in the rotation increase corolis and centrifugal force affects the fluid flow.

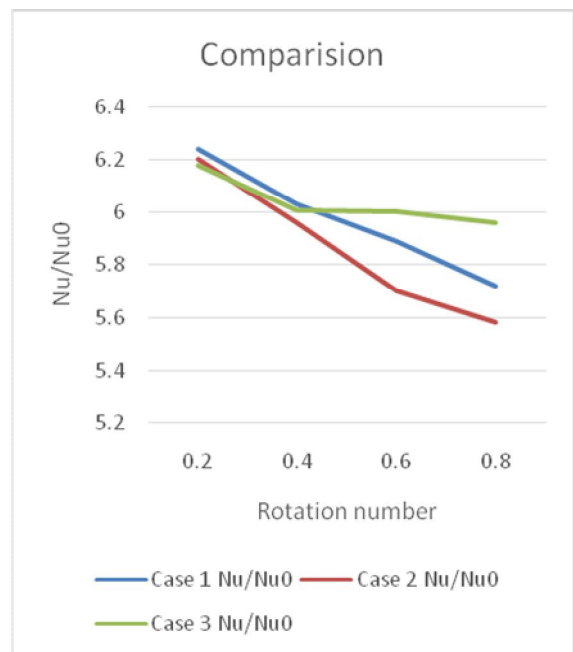

Fig 8 Comparison of three cases

In order to evaluate the heat transfer, average Nusselt number for different cases of ribs arrangement is plotted in figure 8. The figure shows the effect of rotation on the average Nusselt number, upto rotation 0.4 in all the three cases average Nusselt numbers decreases and are well comparable with each other. The rotation beyond 0.4 the average Nusselt number for case1 and case2 reduces, at rotation 0.8 their respective values are 5.7 W/m²k and 5.59 W/m²k. However average Nusselt

number in case3 fairly constant from 0.4 to 0.8, which is about $6 \text{ W/m}^2\text{k}$.

V. CONCLUSION

The study of the heat transfer enhancement in the U-shaped channel with 60° ribs, with rotation effect with different arrangement of ribs on the leading edge of the blade, the following conclusion are drawn.

- The flow separation and reattachment cause the heat transfer enhancement near the ribbed surface.
- Ribbed tabulators structure enhances the heat transfer rate in the heated surface.
- The ribbed channels offer a significant enhancement in heat transfer. The three different ribs arrangement has been studied, thus the parallel ribs shows maximum heat transfer.
- At higher speed the heat transfer decrease due to corolis and centrifugal forces. Therefore higher rotation number cannot be recommended for better cooling.
- The rotation up to 0.4 in all the three cases average Nusselt number decreases.
- The rotation beyond 0.4 the average Nusselt number for case1 and case2 reduces, at rotation 0.8 their respective values are $5.7 \text{ W/m}^2\text{k}$ and $5.59 \text{ W/m}^2\text{k}$ respectively. However average Nusselt number in case3 fairly constant for 0.4 to 0.8, which is about $6 \text{ W/m}^2\text{k}$.

REFERENCE

- [1] V.Ganeshan, Gas turbines, 2nd edition, Tata McGraw-Hill Education, 505,519. 2003.
- [2] S. Gupta A. Chaube and P. Verma 2010 Review on Heat Transfer Augmentation Techniques: Application in Gas Turbine Blade Internal Cooling Journal of Engineering Science and Technology Review 5 (1) (2012) 57-62.
- [3] Han JC. Turbine blade cooling studies at Texas A&M University: 1980-2004, Journal of Thermo physics and Heat Transfer, 2006, 20(2): 161-187.
- [4] N. Kaewchoothong, K. Maliwan and C. Nuntadusit Numerical simulations on flow and heat transfer in ribbed two-pass square channels under rotational effects, Materials Science and Engineering 243(2017) 012004 doi:10.1088/1757-899X/243/1/012004.
- [5] Yao-Hsien Liu, Michael Huh, Je-Chin Han, Hee-Koo Moon, High Rotation Number Effect on Heat Transfer in a Triangular Channel with 45 deg, Inverted 45 deg, and 90 deg Ribs, Journal of Heat Transfer Copyright © 2010 by ASME JULY 2010, Vol. 132 / 071702-1.
- [6] ZhongyangShena, Di Zhangb, YonghuiXiec, Heat transfer enhancement in gas turbine U-shaped channel with rib tabulators under rotational effect, The 6th International Conference on Applied Energy – ICAE2014.
- [7] Muiz Ur Rehman, Waseem Siddique, InamulHaq, Naqash Ali, Zaryab Farooqi, CFD analysis of the influence of guide ribs/vanes on the heat transfer enhancement of a trapezoidal channel, Applied Thermal Engineering 102 (2016) 570–585.
- [8] Michael Göhring, Tobias Krille, Julian Feile, Jens von Wolfersdorf, Heat Transfer Predictions in Smooth and Ribbed Two-Pass Cooling Channels under Stationary and Rotating Conditions, ISROMAC 2016.
- [9] Menter, F. R. , Langtry, R. B., Likki, S. R., Suzen, Y. B., Huang, P. G., and Volker., S., , "A correlation based transition model using local variables part 1 -model formulation", ASME-GT, 2004