

# Load Frequency Control Using Fuzzy Logic Based Pi Controller For Multi Area Power System

Rachana<sup>1</sup>, Subhash<sup>2</sup>

<sup>2</sup> Assistant Professor

<sup>1,2</sup> Sobhasaria Group of Institutions Sikar

**Abstract-** *this paper deals with load frequency control of interconnected power system. In this work single area and two area concepts is considered. The major intention of Load Frequency Control is to sustain the power performance of electric generator within a specified area, due to which alters in frequency of the system and tie-line loading. Thus, Load Flow Controller assists in sustaining the frequency of the system and tie-line power performance with other areas within their specified limits. Mostly LFCs are initially comprises of an integral and PID controller. The gain of the controller is building put to a value that gives better response among fast transient recovery and low overshoot in the performance of the entire power system.*

*In this dissertation work we are using PID controller and fuzzy logic controller. The proposed controller guarantees the stability of the overall closed loop system. Simulation responses for a real two-area power system confirm the usefulness of the proposed LFC and proved its superiority without using controller. The performances of different controllers for variable inputs are compared for the same two area power system. The dynamic response of the load frequency control problems are studied using MATLAB simulink software. The results indicate that the proposed Fuzzy logic controller exhibits better performance*

## I. INTRODUCTION

In our country every person needs the uninterrupted power supply. So it is not promising for the system to stay behind in normal steady state, in view of the fact that both the real and reactive power requirements are continuously alters through growing and diminishing trend. In modern grid power system where a number of equipments are interconnected and power is transferred among them over tie-line, The Automatic Generation Control issue is the major requirement. The deviation among power system generation and demand outcomes in alters the system frequency that is highly undesirable. The excitation of generator should be sustained to contest the reactive power requirement else bus voltage drops beyond the accessible limit. In modern grid power system instruction manual control is not possible; therefore automatic devices are operated on each generator. The major aim of

control scheme is to generate and deliver power in a grid power system as inexpensively and constantly as probable while sustaining the voltage and frequency within their specified limits.

## II. AUTOMATIC GENERATION CONTROL

When the loading in the power grid system increases, due to this its turbine speed falls behind the governor can sustain the input. Due to the fluctuation in the range of speed diminishes the signal of error will be smaller and the arrangements of governor range will be close to the required position, to sustain unvarying speed. Since the unvarying speed will not be the reference value and this will be the offset, to overcome this difficulty an integrator is added, which shall automatically control the generation to re-establish the frequency to its rated value. This technique is named as an automatic generation control (AGC).

The major aim of the Automatic Generation Control is to make steadiness the total system generation alongside all system load and losses, so that the frequency and power substitution with neighboring grid systems are controlled in order to reduce the transient deviations and to afford zero steady state error in particular time.

## III. APPLICATIONS OF AGC

The automatic generation control has many application which are given as following-

- The automatic generation control is applicable in electric grid system for maintaining the power response of multiple generators at dissimilar power plants, in results to variation in the load.
- The automatic generation control is applicable for regulating the frequency and voltage in electric power system for –
  - One area
  - Two area
  - Multiple area

Thus the automatic generation control is applicable in one area, two area and multiple area interconnected power system to maintain the frequency and interchange power between control areas at scheduled value.

**IV. FUZZY LOGIC CONTROLLER**

Since power system dynamic characteristics are complex and variable, conventional control methods cannot provide desired results. Intelligent controller can be replaced with conventional controller to get fast and good dynamic response in load frequency problems. Fuzzy Logic Controller (FLC) can be more useful in solving large scale of controlling problems with respect to conventional controller are slower. Fuzzy logic controller is designed to minimize fluctuation on system outputs. There are many studied on power system with fuzzy logic controller.

A fuzzy logic controller consist of three section namely fuzzifier, rule base and defuzzifier as shown in fig

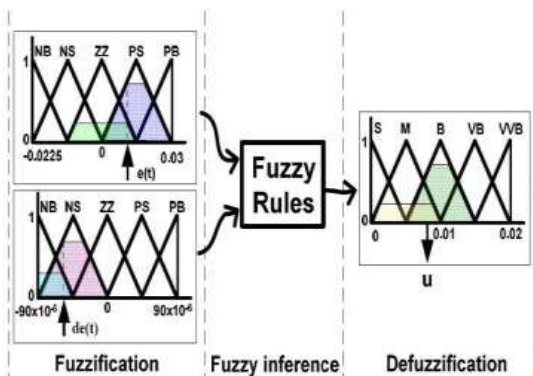

Fig.1. Fuzzy Inference system for FLC

**V. SIMULINK MODEL & RESULTS**

Assumption and Requirement for single area system :-

Extensive testing was involved in the completion of this project. Not only was our final automatic generation control with deregulation tested, but also intermediate steps in the development of that block diagram. The testing of our load frequency control system was done in Matlab Simulation Lab. The testing was completed using the MATLAB Simulink tool. Testing was done on each of the individual blocks of the AGC system and the tests are conducted for single area and two area system without considering deregulation. Each test included in testing the block diagram into simulink and plugging in the values for each of the parameters. Also involved was the addition of the scopes that would be used to measure the outputs of the system. The inputs for each of the text were

varied to allow for more data. The testing forms and the completed testing forms are included in this report.

Requirements

The testing was completed using Matlab Simulink tool.

Limitations

- ⇒ The area control error or the power interchange between areas must be equal to zero at least one time for every 10 minutes.
- ⇒ The average power interchange between areas must be zero in ten minutes period and follow limits of the generation system.
- ⇒ Power interchange between areas must be returned to zero in 10 minutes.
- ⇒ Corrective actions must be accommodating within one minute of a disturbance.

Open Loop AGC System for single Area System

Open loop AGC simulation for single area system is shown in figure 2

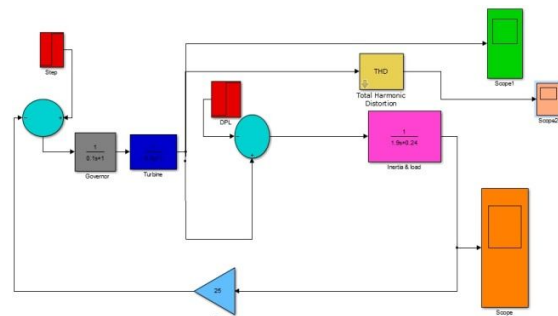

Figure 2 Open Loop AGC single area system

The plot between frequency and time is shown in figure 5.2. It is found that with change in load of 2000 MW, frequency deviates and error is continuously exists in the system. This frequency error must be removed.



Figure 3 Response for open loop single area for change in frequency

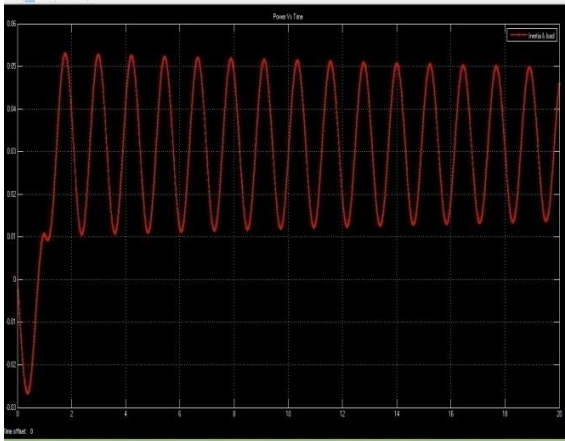

Figure 4 Response for open loop single area Change in power  
It is found from graph that with open loop if demand changes to 0.2 pu, a steady state error exists in frequency of 0.  
Close Loop AGC for Single Area System

System frequency specifications are rather stringent and, therefore, so much change in frequency cannot be tolerated. In fact, it is expected that the steady change in frequency cannot be tolerated. In fact, it is expected that the steady change in frequency will be zero. While steady state frequency can be brought back to the scheduled value by adjusting speed changer setting, the system could undergo intolerable dynamic frequency changes with change in load. It leads to the natural suggestion that the speed changer setting be adjusted automatically by monitoring the frequency changes. For this purpose, a signal from  $\Delta f$  is fed through an integrator to the speed changer. The closed loop AGC system is shown in figure 4.

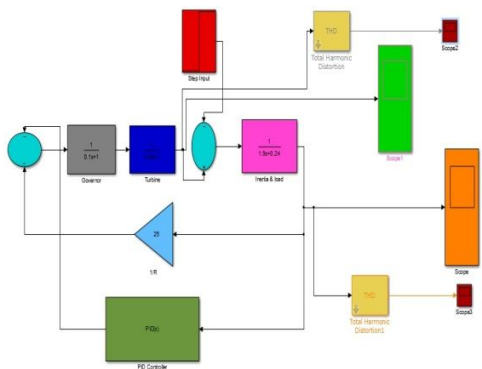

Figure 5 AGC system for single area using PID Controller  
The frequency response is as shown:

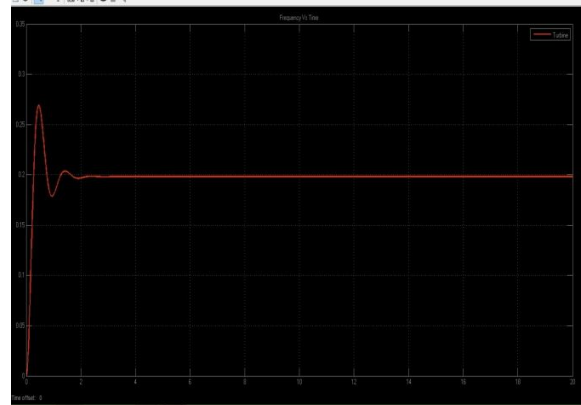

Figure 6 Response for close loop AGC system for change in frequency

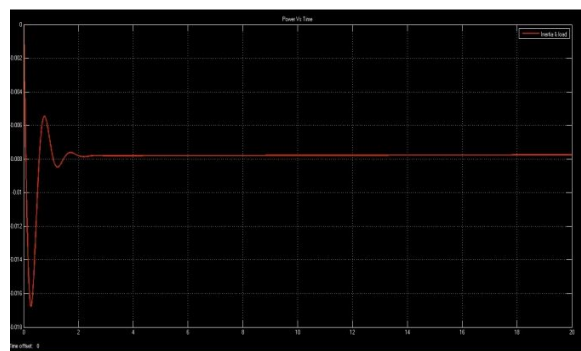

Figure 7 Response for close loop AGC system for change in power

It is concluded that the system now modifies to a proportional plus integral controller, which, as is well known from control theory, gives zero steady state error, i.e.  $\Delta f(\text{steady state}) = 0$ .

### AGC for Three Area System

When we are not connecting any controller results are

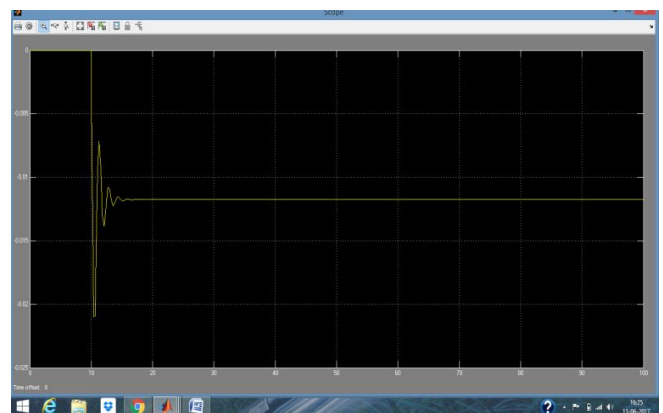

Fig 8 Response for Area 1 AGC system for change in Frequency

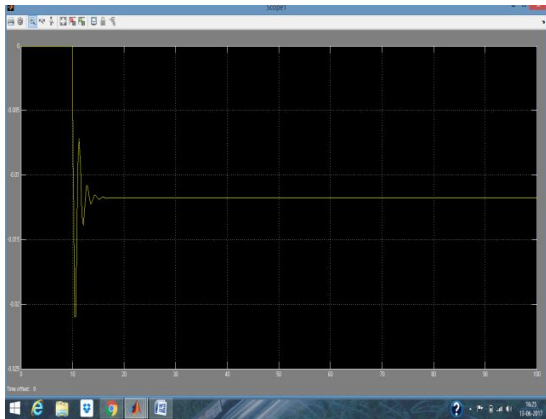

Fig 9 Response for Area 2 AGC system for change in Frequency

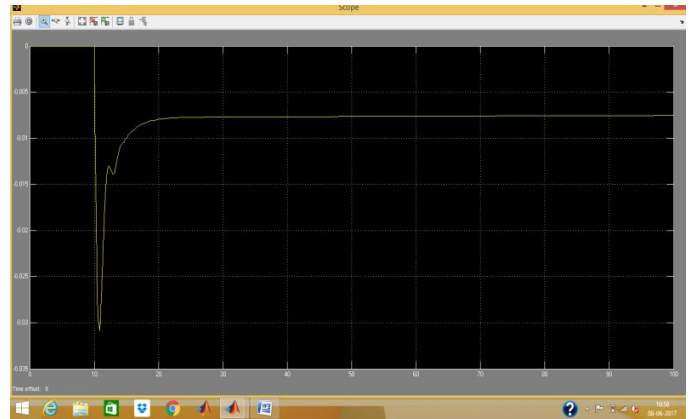

Fig 11 Response for Area 1 AGC system for change in Frequency

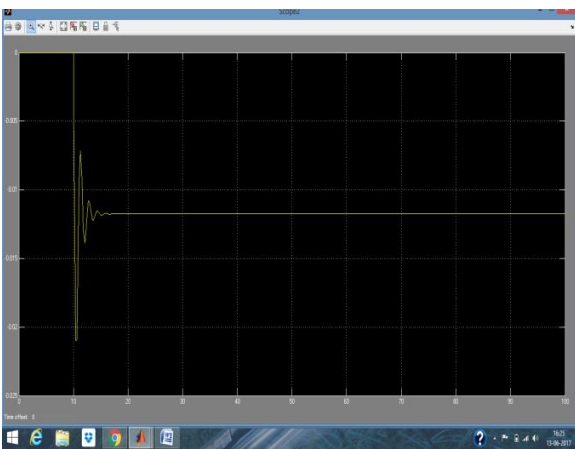

Fig 10 Response for Area 3 AGC system for change in Frequency



Fig 12 Response for Area 2 AGC system for change in Frequency

Firstly we model a two area system using PI Controller and get the outputs of power and frequency of area 1, area 2 and tielines respectively.

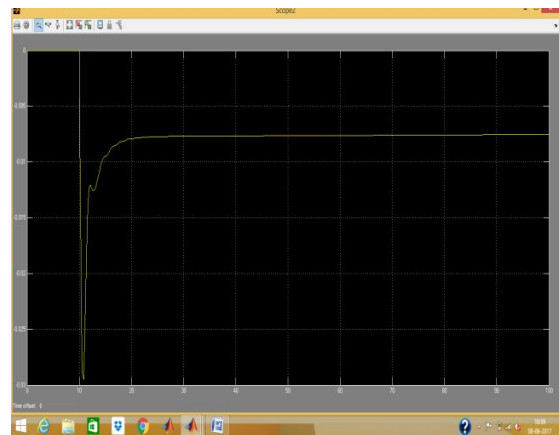
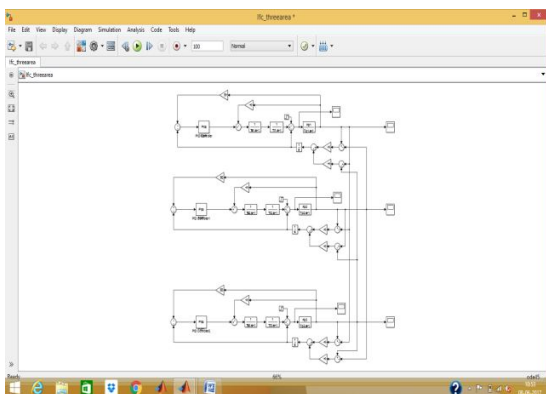

Fig 13 Response for Area 3 AGC system for change in Frequency

### VI. SIMULATION MODEL FOR TWO AREA SYSTEM USING PID CONTROLLER

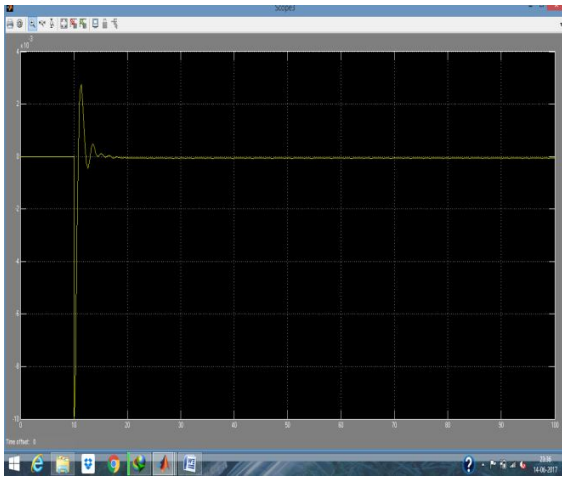

Fig 14 Response for Area 1 AGC system for change in Power

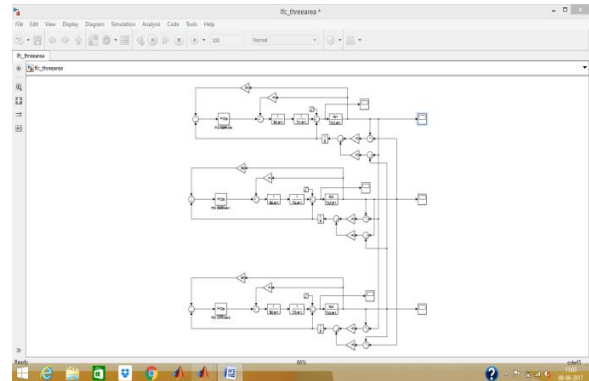

Fig 15 Response for Area 2 AGC system for change in Power

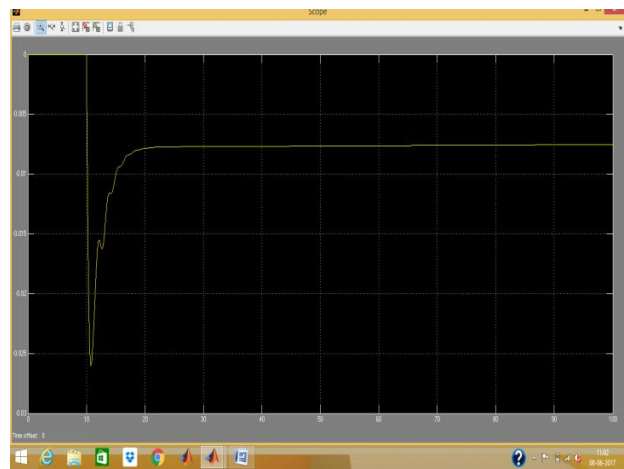

Fig 17 Response for Area 1 AGC system for change in frequency

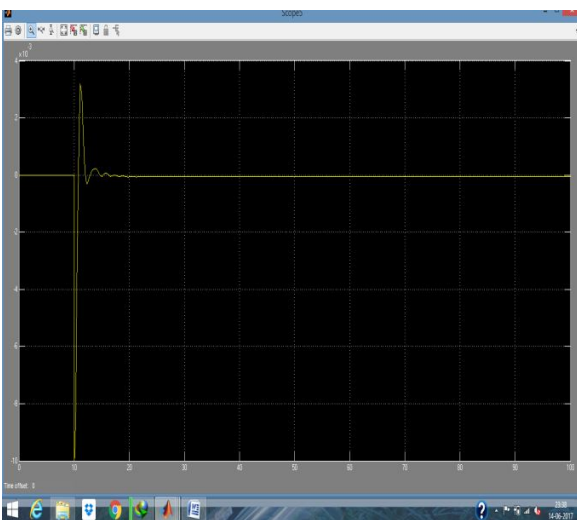

Fig 16 Response for Area 3 AGC system for change in Power

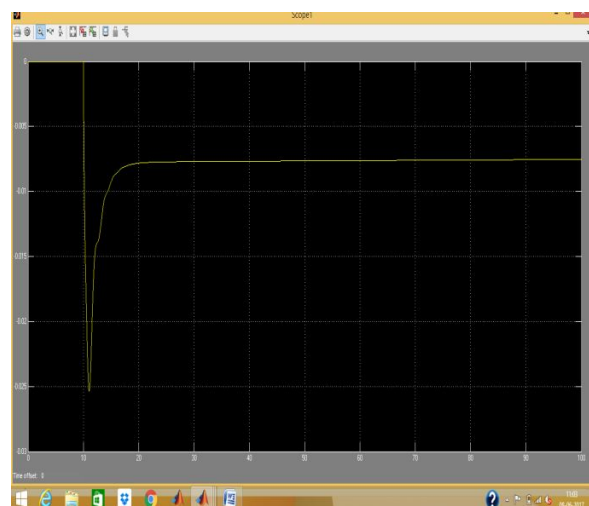

Fig 18 Response for Area 2 AGC system for change in Frequency

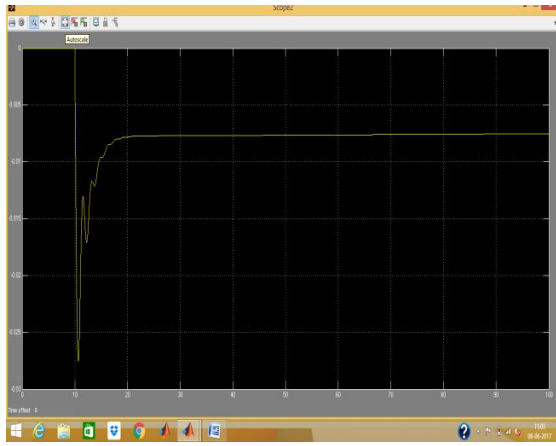

Fig 19 Response for Area 3 AGC system for change in Frequency

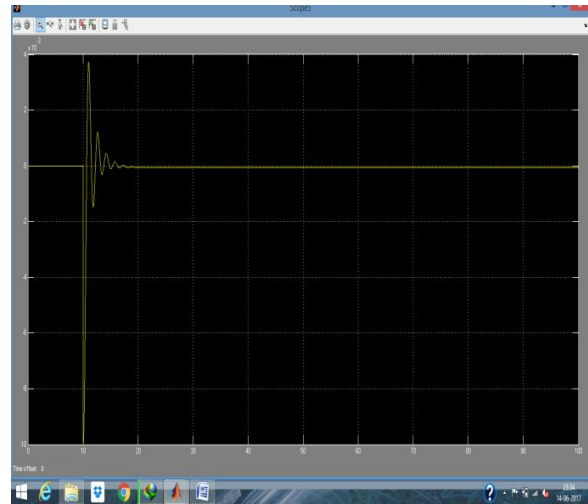

Fig 22 Response for Area 3 AGC system for change in Power



Fig 20 Response for Area 1 AGC system for change in Power

**VII. FUZZY LOGIC CONTROLLER BASED LOAD FREQUENCY CONTROL**

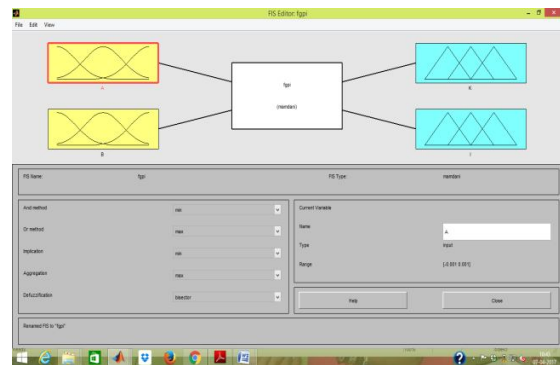

Fig 23 FIS diagram of fuzzy logic

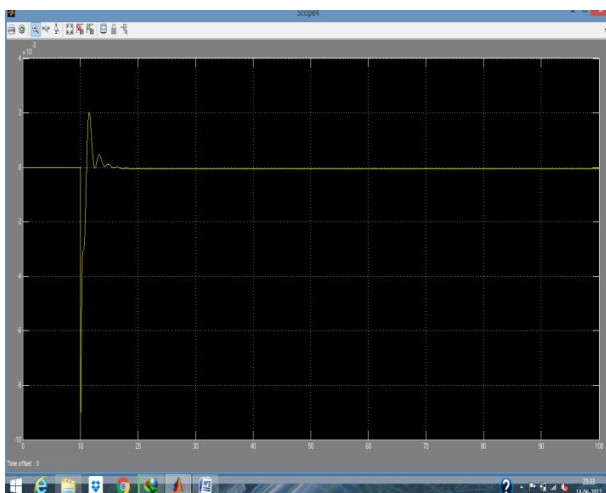

Fig 21 Response for Area 2 AGC system for change in Power

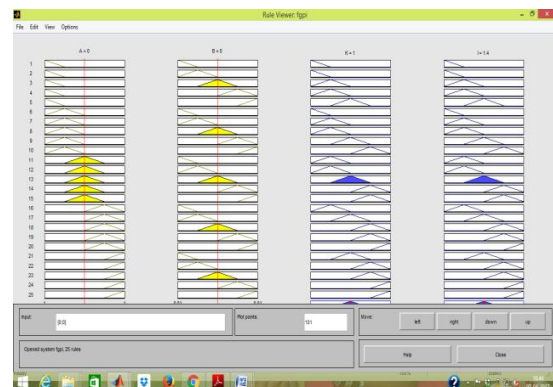

Fig 24 Rule viewer in fuzzy logic controller

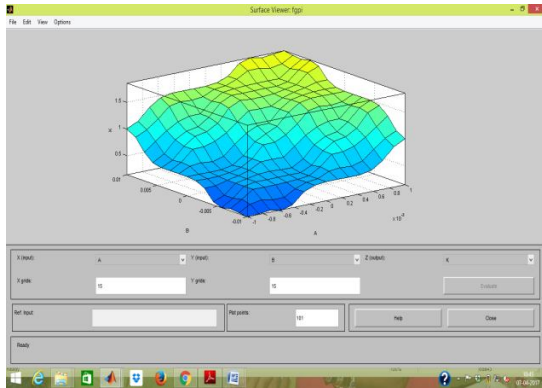

Fig 25 Surface viewer in Fuzzy logic controller



Fig 28 performance graph of change in frequency in area 1 using Fuzzy Logic controller

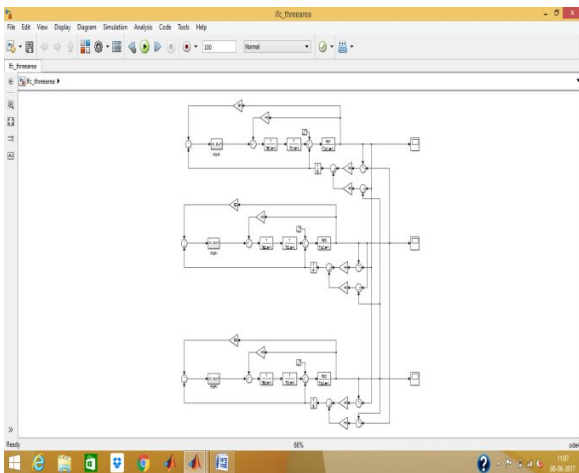

Fig 26 Simulation model of three area system using FLC



Fig 29 performance graph of change in frequency in area 2 using FLC

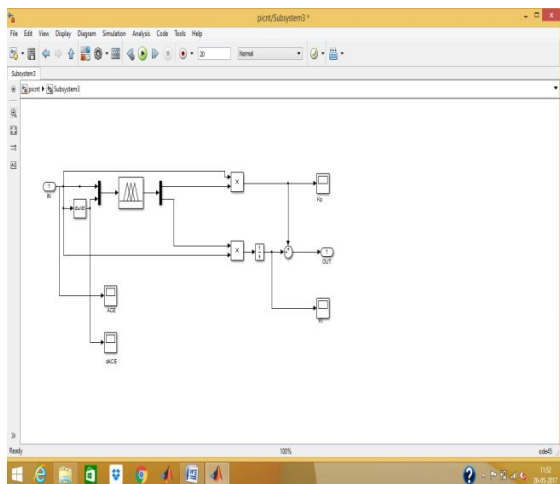

Fig 27 Simulink Model of fuzzy logic controller with PI in MATLAB

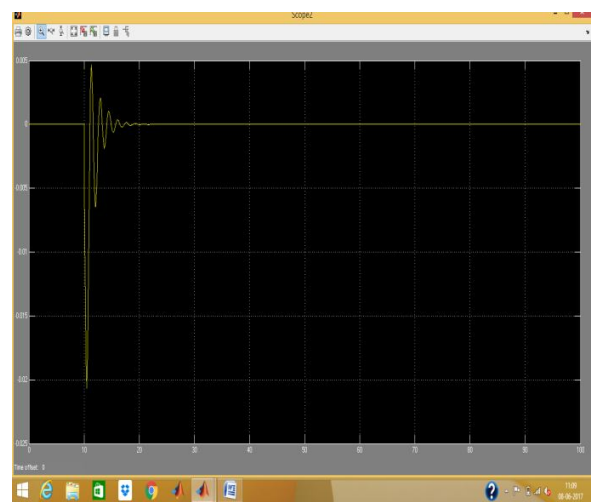

Fig 30 performance graph of change in frequency in area 3 using FLC

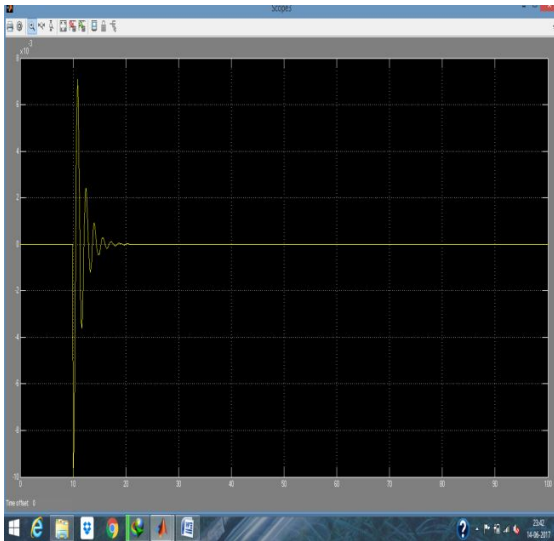

Fig 31 performance graph of change in power in area 1 using FLC

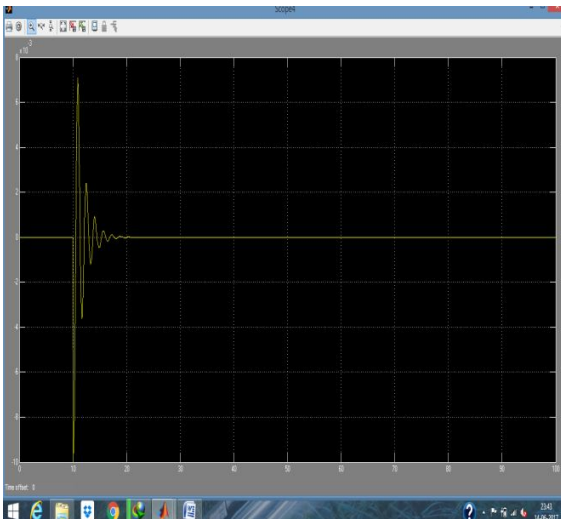

Fig 32 performance graph of change in power in area 2 using FLC

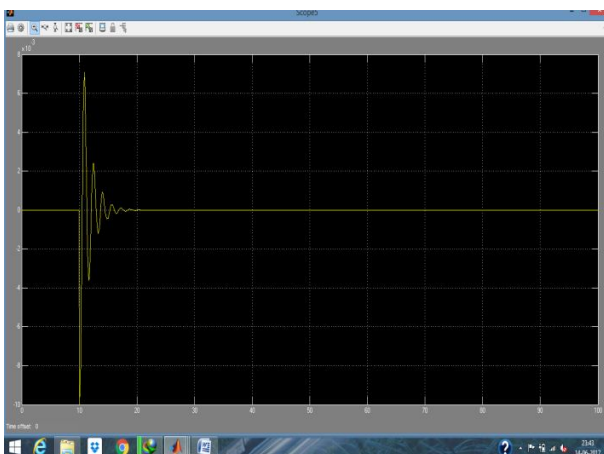

Fig 33 performance graph of change in power in area 3 using FLC

On comparing the results of PI controller, PID controller and fuzzy logic controller. Fuzzy logic controller gives better performance.

## VIII. SUMMARY

This chapter includes the simulation models for one area and two area, with or without using PI, PID and FUZZY Controller. This work shows that by using fuzzy Controller in one area and two area interconnected power system the frequency is restored to its nominal value to get the optimum result or output.

## IX. CONCLUSION

In this we made a simulink model of single area and three area model has been designed. After that PID and fuzzy logic controller is used to reduce the oscillations and settling time. After seeing the results on comparing between without controller and PID controller, PID gives better results and reduced oscillations. But fuzzy logic controller gives more accurate results than PID controller.

## REFERENCES

- [1] Olle I Elgerd, Charles E.Fosha; "Optimum Megawatt-Frequency control of multiarea electric energy systems". IEEE 1970 vol. 4 Pages: 556-563.
- [2] Olle I Elgerd, Charles E.Fosha; "The Megawatt-Frequency control problem: A new approach via optimal control theory". IEEE 1970 vol. 4 Pages: 563-577.
- [3] I.J.Nagrath,D.P.Kothari; "Modern Power System Analysis ", 3rd edition TMH, New Delhi, 2004
- [4] Olle L.Elgerd; "Electrical Energy Systems Theory", McGraw- Hill, New Delhi, 2002.
- [5] Allen J Wood; "Power Generation Operation and Control ", John Wiley and Sons Publishing, 1984.
- [6] Hadi Saadat; "Power System Analysis ", McGraw- Hill, New Delhi, 2002.
- [7] 7. Prabha Kundur; "Power System Stability and Control", Mc Graw- Hill, New Delhi, 2006.
- [8] I.J.Nagrath,D.P.Kothari; " Power System Engineering ", 2nd edition TMH, New Delhi, 2008.
- [9] Kalyan Kumar, M. Deben Singh, Arvind Kumar Singh; "Modeling and simulation of AGC for SCADA based interconnected power system operation" IEEE transactions Pages: 1-10.
- [10] S.C. Tripathy, N. Saha; "A comparative study of the effects of governor dead band nonlinearity on stability of conventional and dynamic load frequency controls". Deptt. Of Electrical Engg, IIT Delhi. Pages: 20-21.



- [11] M.L. Kothari, D.P. Kothari; “Variable structure controller for AGC of interconnected power system”. Pages: 79-82.
- [12] V Ramamurthy, P.S. Kodandaraman Swami; “Combined consideration of enervation controller turbine dynamics and instability analysis”. Pages: 24-25.
- [13] IEEE PES Committee Report, “IEEE Trans. Power App. Syst.,”, vol. PAS-92, Nov. 1973. Dynamic models for steam and hydro-turbines in power system studies.
- [14] IEEE PES Working Group, “Hydraulic turbine and turbine control models for system dynamic,” IEEE Trans. Power Syst., vol. PWRS-7, no. 1, pp. 167–174, Feb. 1992.
- [15] P. Kundur, “Power System Stability and Control.” New York: McGraw- Hill, 1994.