

Memristor Emulator Using Arduino Micro Controller And Digital Potentiometer

Abarna Ermini M¹, Dhanasekar J², Dr. V.K.Sudha³

¹Dept of ECE

²Assistant Professor, Dept of ECE

³Associate Professor

^{1,2}Sri Eshwar College of Engineering, Coimbatore

³Dr.Mahalingam College of Engineering and Technology, Pollachi

Abstract- *In this paper, we are using memristor emulator made up of a Digital Potentiometer (DigPot) and microcontroller (Arduino). This circuit is implemented on a PCB board. The input power supply unit consists of a stepdown transformer. It steps down the input 220V to 9V AC. Then the AC voltage is converted in to DC by a bridge rectifier circuit and regulated by a capacitor filter. When the temperature is varied along an digital potentiometer which in turn produce the signal to MCP3208 microcontroller which acts as an ADC. The input of the ADC is loaded in the FPGA through an SPI and the output is displayed on the LCD screen.*

Keywords- Memristor, Emulator, Digital potentiometer, stepdown transformer, rectifier circuit, Arduino, Microcontroller

I. INTRODUCTION

Memristor is an electrical component that limits or regulates the flow of electrical current in a circuit and remembers the amount of charge that has previously flowed through it. This term memristor was first realized by Leon O. Chua in 1971, there are existed three passive element i.e., resistor, capacitor and inductor. They relate the variable as voltage-current, charge-voltage and flux-current. However, there was a missing relation between flux and charge. So Chua proposed a mathematical model which can give the relation between that variable called the memristor (1). memristive device and system can be implemented [2]. When the electric power supply is turned off, the memristor remembers its most recent resistance until it is turned on again. (3, 4). In 2008, a team at [HP Labs](#) claimed to have found Chua's missing memristor based on an analysis of a [thin film](#) of [titanium dioxide](#) thus connecting the operation of [RRAM](#) devices to the memristor concept (3). The theory of the fourth fundamental circuit element however remained a puzzle for decades as there was no physical implementation to back it up. As some scholars have argued, this was due in part to the existing technology and also the memristor being a nano-scale device even though for decades, memristive behaviors have been

unwittingly observed [5, 6, 7, 8, 9] The memristor can be considered as a time varying resistor whose resistance depends on the history of current that has passed through it Its resistance changes as a result of the summation of current that has passed through the device. When the current flowing through the device is zero, the summation of current becomes constant, and thus the resistance remains unchanged. This gives the memristor the potential of being adopted as a non-volatile memory component [10].

In 2008, researchers from Hewlett Packard labs announced the realisation of one of the first physical solid-state memristors [11]. Afterwards, there's been a lot of interest in exploiting this emerging circuit element especially in their applications in analogue circuitry, particularly exploiting their non-volatile memory. This is in revenge, due to their fine resolution programmability An examples of memristor application in programmable analogue ICs is in demonstrated in [12] where a memristor is designed for a pulse-programmable mid-band differential gain amplifier, the total output resistance is made programmable by use of a memristor. Another practical example of memristor application is in a programmable threshold comparator [13], here, a technique is used to control the charge integrated in the memristor thereby implementing a programmable hysteresis. Recently, chances of Memristor-based Vision Processors have also been investigated. In [14], a light-to-resistance encoder exploiting the properties of a memristor is presented whereas other memristor-based image processing algorithms are continually being exploited [15, 16, and 17].

Most of the emulators which have been published rely on discrete electrical components which are either complicated to build or are resource hungry. In this paper, we propose an easy way of mimicking the properties of the memristor with an Arduino-controlled digital potentiometer. This approach takes advantage of the Arduino's capability to communicate with other components through its SPI ports and most especially it can be easily programmed and reconfigured. Since the whole idea is to simplify things, data acquisition done by a PC interfaced with the Arduino through the serial

port. This way data acquired from the Arduino is plotted in real-time using some sort of serial monitor.

II. LITERATURE SURVEY

Memristor emulator imitates the behavior of a TiO_2 memristor is presented. Most of the emulator is built from off-the-shelf solid state components. To make the real world memristor current application.

The first memristor emulator as CMOS based memristor emulator. It is made up of four Differential Difference Current Conveyor (DDCC) as integrator, squarer, multiplier and summer. This type of memristor emulator provides less complexity and it operates at high frequency also. It has some drawbacks such as increasing power consumption and it required more space to occupy.

To overcome this drawbacks by using a simple MOS realization of current-controlled memristor emulator. This paper was postulated by A.I.Hussien and M.E.Fouda. This type of emulator consists of one Voltage Control Resistor (VCR) and one second generation Current Conveyor (CCII). We know that the memristor is a variable resistor which changes it's depending on the charge passing through it. So, it can be emulated by VCR, where control voltage is proportional to the passing charge through the device. The control voltage is generated by mirroring the current passing through VCR and imposing it into a capacitor. So voltage across the capacitor is required. $V_c = q_{in}/C$.

CCII can be implemented using TSMC0.13 μm technology with dual supply $\pm 1.5\text{v}$ and has three terminal i.e., two input terminal and one output terminal. It required minimum supply voltage and decreasing offset voltage between two input terminals. In VCR is essential element in different electronic circuit such as variable gain amplifier and signal generator. The MOS based memristor emulator giving a high functionality to work in any frequency range and it was easily integrated with MOS circuit in integrated circuit.

Another type of memristor emulator as flux-controlled memristor emulator. The emulator circuit is built by using CA3080 and AD844AN for OTA and CCII. The memristance value of the emulator circuit is adjustable by means of a simple change of trans conductance parameter (gm) of the operational transconductance amplifier in the emulator circuit. The flux- controlled memristor emulator consists of three operational transconductance amplifier, four second generation current conveyor, six resistor and one capacitor. The transconductance parameter of OTA is proportional to the current flowing its bias current terminal.

The features of the emulator circuit is the possibility of controlling memristance value by change of trans conductance amplifier via a bias voltage. It is used for real world application such as chaotic signal, programmable analog circuit.

The other model is flux- controlled floating analog memristor emulator circuit based on CCII built from few active devices and passive elements. The CCII is realized by an AD844AN. The current in the terminal of each AD844AN is labeled by the number of each active devices There are two possibilities to control the memristor, Whereas memristor is charge controlled and memristor is flux controlled.

For the frequency analysis , the frequency of the exciting source increases to infinite entail that the linear time varying resistor of memristor is reduced to zero. the cubic function is used for modeling the charge or flux controlled memristance but incremental memristance is modeled by a first order function. it provide good accuracy and easily reproducible at low cost. It is used for sensors, cellular neural network, chaotic systems, programmable analog circuit and non-volatile memory device.

Another model is Practical Approach to Programmable Analog Circuits With Memristors. The main element of the memristor emulator is a digital potentiometer whose resistance is continuously updated by a microcontroller and determined by pre-programmed equations of current-controlled or voltage-controlled memristive systems. A voltage drop on the memristor measured by the analog- to-digital converter (ADC). It has some drawbacks due to resolution of digital signal and digital potentiometer.

III. PROPOSED SYSTEM

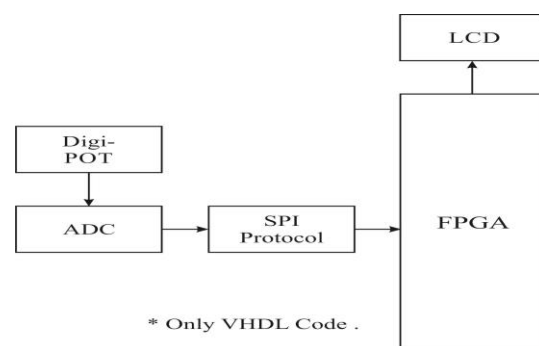

In this paper, we are simulating the Arduino controlled memristor emulator by using Xilinx ISE. Here the memristor emulator is composed of digital potentiometer and MCP3208. The memristor emulator has been implemented in such a way that the input resistance is calculated as a function

of the applied current or voltage to satisfy the equations of the memristor is given by

$$v(t) = \left(R_{ON} \frac{w(t)}{D} + R_{OFF} \left(1 - \frac{w(t)}{D} \right) \right) i(t)$$

The working principle of the emulator is simple and self explanatory. The analog-to-digital converter (ADC) of the Arduino continuously samples the voltage drop across the emulator which in turn is used to the emulator's equivalent resistance based on the mathematical equations governing the functionality of the memristor. The Communication between the DigPot and the Arduino is attained through Serial Peripheral Interface (SPI) bus meanwhile the emulator can be easily connected to other electronic devices. The schematic of the memristor emulator which consist of an Arduino due, and an MCP3208 digital potentiometer. The MCP3208 A/D converters employ a conventional SAR architecture. With this architecture, a sample is acquired on an internal sample/hold capacitor for 1.5 clock cycles starting on the fourth rising edge of the serial clock after the start bit has been received. Following this sample time, the device uses the collected charge on the internal sample/hold capacitor to produce a serial 12-bit digital output code. Conversion rates of 100 ksp/s are possible on the MCP3204/3208. Communication with the device is accomplished using a 4-wire SPI compatible interface.

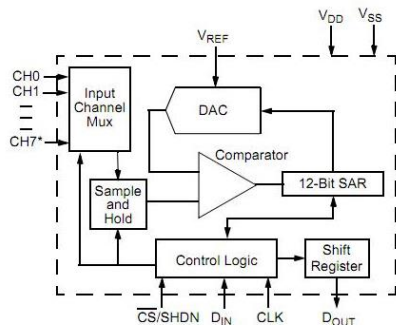

Functional block diagram of MCP3208

The need of sample and hold circuit as discussed, the ADC takes finite time, called the conversion time, to give a digital output to corresponding analog input value. If the analog input signals are not stable during conversion time, the digital output will not be the true representation of its analog value. This may lead to error in digital converted data. This error will be some function of the highest frequency and uncertainty in time. In order to overcome this problem, the sample and hold (S/H) circuit is used. This increases the system bandwidth (BW) without change in the accuracy.

The sample and hold circuit has two modes;

- Sample mode
- Hold mode

In the sample mode, the output follows the input with unity gain whereas in the hold mode retains the last value of the sample when the switch was opened.

The basic sample and hold circuit consists of a switch and a capacitor as shown. When the switch is closed, the capacitor is charged to the instantaneous value of the input signal voltage and when it is opened, it holds the voltage. This process of charging and holding the voltage assumes very high value of load impedance. If the load impedance is not high, then the charge on the capacitor will, start leaking through the low value of the load impedance and the held voltage will never be constant.

If the time constant RC is very small, the capacitor C will be charged to the sample value very rapidly. Hence during the sample interval, the sample voltage very closely follows the input voltage and during the hold interval, the capacitor holds the sampled value. This happy situation does not hold good in practice, as capacitors and switches are not perfect. There are many types of deviations from the ideal situation. The important specifications worth mentioning for the selection of switches are

- Aperture time
- Acquisition Time.

The Arduino which in turn communicates with the digital potentiometer through the Serial Peripheral Interface (SPI). The Arduino samples the voltage difference between two terminals of potentiometer resistance network. The data is collected from the sensor through the serial port and plotted on a LCD screen. The performance analysis of the design is verified using Xilinx software.

IV. RESULT

When temperature is varied across the digput the output is voltage varies. The variation is shown in the LCD display. Here the memristor emulator is composed of digital potentiometer and microcontroller. The working principle of the emulator is simple and self explanatory. The analogue-to-digital converter (ADC) of the Arduino continuously samples the voltage drop across the emulator which in turn is used to the emulator's equivalent resistance based on the mathematical equations governing the functionality of the memristor. The Communication between the DigPot and the Arduino is attained through Serial Peripheral Interface (SPI) bus meanwhile the emulator can be easily connected to other

electronic devices. The digital signal transmitted to the FPGA through the SPI bus and finally, the output of FPGA is displayed on the LCD screen.

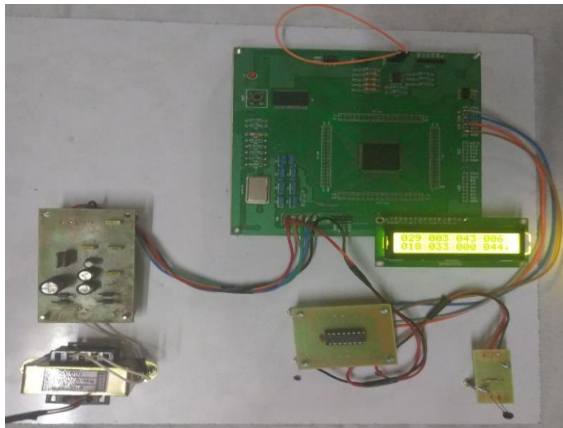

V. CONCLUSION

In this paper, we used memristor emulator made up of a Digital Potentiometer (DigPot) and microcontroller (Arduino). Mostly the emulator is composed of off-the-shelf electronic component. Here we are using MCP3208 microcontroller, because it has 12-bit resolution, low power CMOS technology and low cost to made etc. Arduino as a analog-to-digital converter and it used to read the voltages at the terminal of the digital potentiometer. This digital potentiometer is continuously updated through the SPI port based on the microcontroller. The data is collected from the one or more sensor network through the serial port. The performance characteristic can be successfully verified by using hardware.

REFERENCES

- [1] L. O. Chua, Nonlinear circuit foundations for nanodevices. i. the four-element torus, *Proceedings of the IEEE* 91 (11) (2003) 1830–1859.
- [2] J. M. Tour, T. He, Electronics: the fourth element, *Nature* 453 (7191) (2008) 42–43.
- [3] D. Lin, L. Chua, S.-Y. Hui, The first man-made memristor: Circa 180 [scanning our past], *Proceedings of the IEEE* 103 (1) (2015) 131–136.
- [4] T. Prodromakis, C. Toumazou, L. Chua, Two centuries of memristors, *Nature materials* 11 (6) (2012) 478–481.
- [5] O. Ageev, Y. F. Blinov, O. Ilin, A. Kolomiitsev, B. Konoplev, M. Rubashkina, V. Smirnov, A. Fedotov, Memristor effect on bundles of vertically aligned carbon nanotubes tested by scanning tunnel microscopy, *Technical physics* 58 (12) (2013) 1831–1836.
- [6] A. Chanthbouala, V. Garcia, R. O. Cherifi, K. Bouzehouane, S. Fusil, X. Moya, S. Xavier, H. Yamada, C. Deranlot, N. D. Mathur, et al., A ferroelectric memristor, *Nature materials* 11 (10) (2012) 860–864.
- [7] X. Wang, Y. Chen, H. Xi, H. Li, D. Dimitrov, Spintronic memristor through spin-torque-induced magnetization motion, *IEEE electron device letter* 30 (3) (2009) 294–297.
- [8] L. Chua, Memristor - the missing circuit element, *IEEE Trans. Circuit Theory* (18) (1971) 517–519.
- [9] L. O. Chua, S. M. Kang, Memristive devices and systems, *Proceedings of the IEEE* 64 (2) (1976) 209–223.
- [10] Y. V. Pershin, M. Di Ventra, Memory effects in complex materials and nanoscale systems, *Advances in Physics* 60 (2) (2011) 145–227.
- [11] R. S. Williams, How we found the missing memristor, *IEEE spectrum* 45 (12) (2008) 28–35.
- [12] S. Shin, K. Kim, S.-M. Kang, Memristor applications 330 for programmable analog ics, *Nanotechnology, IEEE Transactions on* 10 (2) (2011) 266–274.
- [13] O. A. Olumodeji, M. Gottardi, Memristor-based comparator with programmable hysteresis, in: *Microelectronics and Electronics (PRIME), 2015 11th Conference on Ph. D. Research in, IEEE, 2015*, pp. 232–235.
- [14] O. A. Olumodeji, A. P. Bramanti, M. Gottardi, A memristor-based pixel implementing light-to-resistance conversion, *Opt. Eng.* 55 (2). doi:10.1117/1.OE.55.2.020501.
- [15] C. Yakopcic, T. M. Taha, G. Subramanyam, S. Rogers, Memristor-based unit cell for a detector readout circuit, in: *SPIE Optical Engineering+ Applications, International Society for Optics and Photonics, 2011*, pp. 81651F–81651F.
- [16] O. A. Olumodeji, A. P. Bramanti, M. Gottardi, Memristor-based pixel for event-detection vision sensor, in: *SENSORS, 2015 IEEE, 2015*, pp. 1–4. doi:10.1109/ICSENS.2015.7370688.
- [17] O. Olumodeji, A. Bramanti, M. Gottardi, A memristive pixel architecture for real-time tracking, *IEEE Sensors Journal* 16 (22) (2016) 7911.
- [18] S. Yener, H. Kuntman, A new CMOS based memristor implementation, in: *Applied Electronics (AE), 2012 International Conference on, IEEE, 2012*, pp. 345–348.
- [19] A. I. Hussein, M. E. Fouda, A simple MOS realization of current controlled memristor emulator, in: *2013 25th International Conference on Microelectronics (ICM), IEEE, 2013*, pp. 1–4.
- [20] H. Sözen, U. C. Am, New memristor emulator circuit using opamps and diodes.
- [21] C. Sánchez-López, J. Mendoza-López, M. Carrasco-Aguilar, C. Muñoz-Montero, A floating analog memristor

- 355 emulator circuit, *Circuits and Systems II: Express Briefs*, IEEE Transactions on 61 (5) (2014) 309–313.
- [22] A. G. Alharbi, M. E. Fouda, M. H. Chowdhury, Memristor emulator based on practical current controlled model, in: 2015 IEEE 58th International Midwest Symposium on Circuits and Systems (MWSCAS), IEEE, 2015, pp. 1–4.
- [23] H. Kim, M. P. Sah, C. Yang, S. Cho, L. O. Chua, Memristor emulator for memristor circuit applications, *Circuits and Systems I: Regular Papers*, IEEE Transactions on 59 (10) (2012) 2422–2431.
- [24] Y. V. Pershin, M. D. Ventra, Practical approach to programmable analog circuits with memristors, *Circuits and Systems I: Regular Papers*, IEEE Transactions on 57 (8) (2010) 1857–1864.
- [25] Y. N. Joglekar, S. J. Wolf, The elusive memristor: properties of basic electrical circuits, *European Journal of Physics* 30 (4) (2009) 661.
- [26] J. Valsa, D. Biolek, Z. Biolek, An analogue model of the memristor, *International Journal of Numerical Modelling: Electronic Networks, Devices and Fields* 24 (4) (2011) 400–408.
- [27] D. B. Strukov, G. S. Snider, D. R. Stewart, R. S. Williams, The missing memristor found, *Nature* 453 (7191) (2008) 80–83.
- [28] Y. Ho, G. M. Huang, P. Li, Dynamical properties and design analysis for nonvolatile memristor memories, *IEEE Transactions on Circuits and Systems I: Regular Papers* 58 (4) (2011) 724–736.
- [29] J. Blanc, D. L. Staebler, Electrocoloration in TiO_2 : Vacancy drift and oxidation-reduction of transition metals, *Physical Review B* 4 (10) (1971) 3548.
- [30] M. P. Sah, C. Yang, H. Kim, L. Chua, A voltage 380 mode memristor bridge synaptic circuit with memristor emulators, *Sensors* 12 (3) (2012) 3587–3604.
- [31] Z. Biolek, D. Biolek, V. Biolkova, Spice model of memristor with nonlinear dopant drift, *Radioengineering* 18 (2) (2009) 210–214.
- [32] O. A. Olumodeji, M. Gottardi, Emulating the physical properties of hp memristor using an arduino and a digital potentiometer, in: Ph. D. Research in Microelectronics and Electronics (PRIME), 2016 12th Conference on, IEEE, 2016, pp. 1–4.
- [33] L. O. Chua, The fourth element, *Proceedings of the IEEE* 100 (6) (2012) 1920–1927.