

Design And Analysis of Horizontal Openwell Submersible Pump

Guruparan.R¹, Arunpranesh.M², Gogulakrishnan.A³, Mareeswaran.M⁴

¹Dept of Mechanical Engineering

^{2,3,4}Assistant Professor, Dept of Mechanical Engineering

^{1, 2, 3, 4} Kathir College of Engineering, Coimbatore, India

Abstract- In India, Bureau of Indian standards gives only an overall configuration about horizontal open well submersible pump. Most of the Indian manufacturers produce horizontal open well submersible pumps on trial and error basis. They make their own winding combination in order to optimize the performance. In case of submersible pumps various parameters are redesigned in various stages to maximize the performance.

In our project, we have analyzed the horizontal open well submersible pump manufactured by cheran industries & reduced the weight of the pump by removing the unwanted material.

The weight reduction is done on the components like back cover, impeller, rotor shaft, stator, front cover and the efficiency is same as the existing pump design with economic price.

I. INTRODUCTION

A pump is a device or an apparatus used for conveying a fluid from one point to other, usually through a pipe. A pump may, therefore, be defined as a mechanical device which translates the mechanical energy imparted to it from an external source (electric motor, diesel engine or even manual energy) into hydraulic energy in the fluid handled by it. As a consequence, the energy level of fluid handled by the pump or flowing through the pump is augmented, making it possible for the fluid to move from a lower level to a higher level, against gravity and friction.

In submersible motor pump sets, both pump and the unusually long, small diameter motor are installed deep inside the tube well so that suction lift is minimized which make it possible to lift water from depths as low as 450 metres. These pumps are essentially single or multistage centrifugal turbine pumps designed to form a compact unit in conjunction with a coupled wet type squirrel cage induction motor both of which operate totally submerged below the surface of water. A submarine armoured cable and a small copper oil tube form

the only connection beside the discharge pipe between the pumping unit and the surface of the ground.

Submersible pumps with radial flow impellers are made for low discharge with high total heads, whereas pump switch mixed flow type impellers are made for medium discharge range with medium heads.

II. METHODOLOGY

Analyzed the old pump details and reduce length of shaft and modify the whole structure for the reduced shaft without changing the efficiency of the pump.

In this chapter, three dimensional view of Impeller, Rotor Shaft, Back Cover, Front Cover, Body are designed using Pro-E and analyzed by Ansys Software in order to increase the Efficiency of the pump.

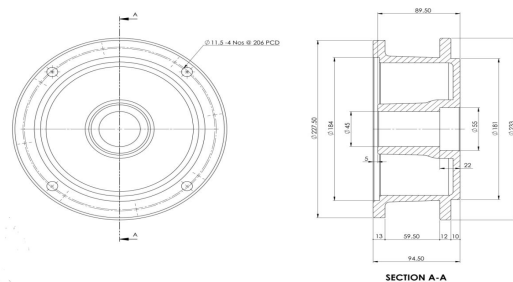

Modified Stator Design

TABLE I MATERIALS PROPERTIES

NAME	MATERIAL
Compressive strength	570 to 1290 MPa (83 to 187 *10 ³ psi)
Density	7.2 g/cm ³ (450 lb/ft ³)
Elastic modulus	66 to 160 GPa (9.6 to 23*10 ⁶ psi)
Fatigue strength	69 to 169 MPa (10 to 25*10 ³ psi)
fracture toughness	320 to 650 MPa-m ^{1/2}
Shear strength	179 to 610MPa (26 to 88*10 ³ psi)
Specific heat capacity	450 J/kg-K
Strength of weight ratio	19 to 60 KN-m/kg
Ultimate tensile strength	140 to 430MPa (20 to 62*10 ³ psi)
Yield tensile strength	98 to 276 MPa (14 to 40*10 ³ psi)

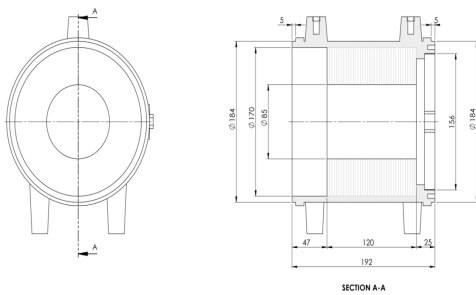
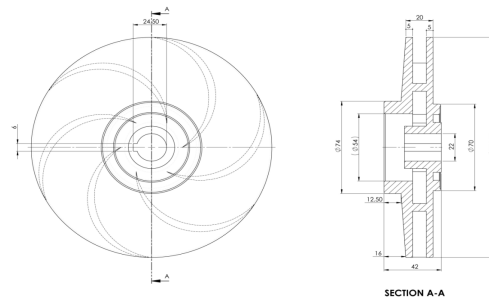

Modified Shaft Design

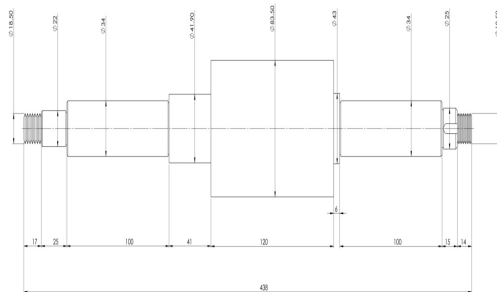
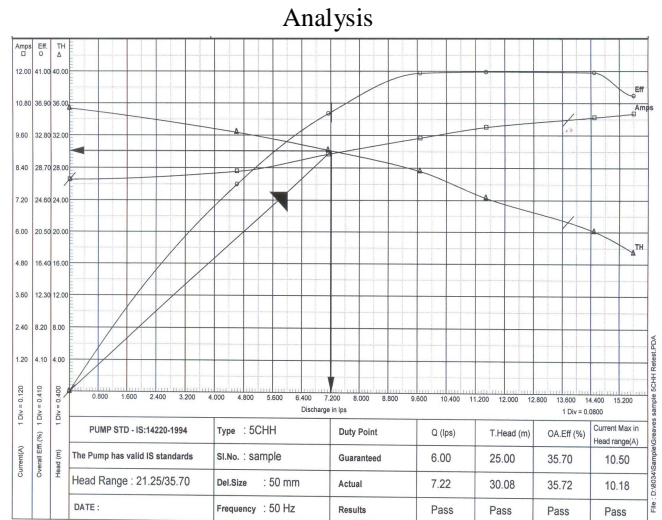

Modified Back Cover Design

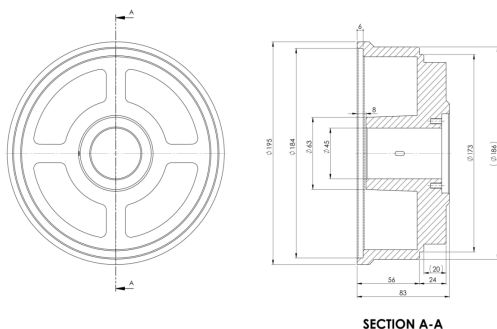

Modified Impeller Design

III. CONCLUSION

The major findings drawn from each chapter of this work are summarized in this chapter.

The literature survey showed that the size of the pump has been reduced without changing its performance and efficiency.

Pump STD IS 14220-1994	TYPES:5CHH	Duty point	Q(lps)	T-Head	Qa eff(%)	Current Max head range(A)
The pump has valid ISD	Sl.no: sample	guaranteed	6.00	25.00	35.70	10.50
Head Range:21.25 /35.70	Del.size: 50mm	actual	7.22	30.08	35.72	10.18
Date:	Frequency: 50Hz	results	pass	pass	pass	pass

The following is a summary of findings which have been mentioned earlier, and they would add to the current state of the art:

REFERENCES

- [1] Alberti et al (2011), Empirical Mode Decomposition-Extended Kalman Filter (EMD-EKF) Vol.36, No.5
- [2] Boglietti et al (2007), Investment Casting Technological Process.
- [3] Burakov and Arkkio (2007), Comparison of the Unbalanced Magnetic Pull Mitigation by the Parallel Paths in the Stator and Rotor Windings, vol.22
- [4] Chandrasekhar, v.and Manigandan, T. “ Double Winding Induction Motor- an Approach for Improvement of Power Factor and Efficiency”, European Journal of Scientific Research, Vol.66, No.2
- [5] Francesco Parasiliti (2005), European Classification Scheme (EC/CEMEP) .
- [6] Herman, Stephen L. Industrial Motor Control. 6th ed. Delmar Cengage Learning, 2010.
- [7] Manoharan et al (2010), Die-cast Copper Rotor (DCR) technology. International Journal of computer and Electrical Engineering, Vol.2, No,3.
- [8] Maswood et al (2006), A submersible motor with an advanced delta-modulated inverter driver. Vol.22, No,2.
- [9] Nicola Tesla (1888), Serbian-American engineer made journal in the production, transmission and application of induction motor. Vol.23, No,4.
- [10] Pillay et al (1998), Situ Induction Motor Efficiency Determination using the Genetic algorithm IEEE E-1 and F-1 methods vol. 13,no.4.