

# Automatic Electricity Bill Generation And Fraud Detection

Bhadane Sayali S<sup>1</sup>, Neharkar Priya B<sup>2</sup>, Barve Sayalee D<sup>3</sup>, Prof. S. B. Bhosale<sup>4</sup>

<sup>1,2,3,4</sup> Dept of Computer Engg

<sup>1,2,3,4</sup> Jaihind College of Engineering, Kuran.

**Abstract-** Power is one of the fundamental necessities in this day and age. It is critical to proficiently give power to the substantial people. One of the imperative advance in appropriate transmission and use of power is its metering. Presently a-days power meter perusing and charging is led physically by way to-entryway framework. This framework requires expansive measure of labor and furthermore time and vitality utilization. There is huge number of energy robberies from local and mechanical supply lines. There is dependably a differentiation between the purchaser and the provider that the buyer will pay for the power devoured by him. In any case, in India close around 32 % of the power is devoured yet not paid for it i.e. it is being stolen by the customer henceforth the need of a framework emerges that would beat this burglary of power.

To defeat the constraints of this customary framework propelled remote innovation called "ZIGBEE" is utilized. The proposed module decreases time deferral and robbery of power. ZigBee is favored over different remote advancements since it works in unlicensed recurrence band, it doesn't require fast information rate, likewise this gadget is low fueled and ease. The microcontroller based framework consistently screens the perusing and robbery identification.

**Keywords-** Sensors, Energy Meter, LCD, Microcontroller, Relay, ZigBee,GSM

## I. INTRODUCTION

The present world is outfitted with all the savvy things in each snapshot of life. For example, savvy living, keen condition, shrewd urban areas, advanced mobile phones, and so on. To add to this intelligence, we propose brilliant power charging framework and burglary recognition. Power is one of the fundamental necessities in this day and age. It is the most helpful and profitable type of vitality. It is critical to proficiently give power to the extensive people. One of the essential advance in appropriate transmission and utilization of power is its metering. Recently, the vast majority of the nations, regardless of whether created or creating, have swung to computerized meters. The fundamental need is to lessen the vitality utilization of the meter. Most creating nations require

human mediation for taking the power meter perusing. This expands work expenses and vitality is squandered by the individual while making a trip to the different shopper destinations. Likewise despicable and inconvenient charging comes about which prompts loss of unaccounted vitality and printed material.

Presently a-days power meter perusing and charging is directed physically by way to-entryway framework. This framework as watched requires a lot of labor and furthermore time and vitality utilization. There is huge number of energy burglaries from household and modern supply lines. There is dependably a complexity between the shopper and the provider that the purchaser will pay for the power devoured by him. Be that as it may, in India close around 32 % of the power is expended yet not paid for it i.e. it is being stolen by the shopper consequently the need of a framework emerges that would conquer this robbery of power.

To conquer the constraints of this conventional framework propelled remote innovation called "ZIGBEE" is utilized. ZigBee is favored over different remote advancements since it doesn't require fast information rate, likewise this gadget is low fueled and minimal effort. The microcontroller based framework consistently screens the perusing and robbery recognition. Transfer is utilized to cut power supply in the event that burglary is identified or purchaser did not paid his/her power charge regardless of the possibility that due date is passed. ZigBee is bidirectional. It gets and transmits information to and from specialist. This framework likewise enhances the exactness, effectiveness and furthermore we can have remote access of meter.

System Design:-

The system is divided into two modules: Consumer Side and Electricity Board Side.

Consumer Side:-

Customer side module comprises of vitality meter, microcontroller, LCD show, voltage sensor, current sensor, and ZigBee module. We utilized LPC2148 Microcontroller. It

constantly screens the vitality meter perusing and robbery in electricity. Theft is identified when buyer tempers the meter by-passing it. The breakers at either side of meter are specifically associated through a directing wire henceforth the meter will be totally circumvent that incites voltage sensors. The LPC2148 microcontroller is specifically interfaced with ZigBee module. This robbery flag is shown on LCD show on shopper side and transmitted to EB side through ZigBee Transmitter. The LCD show demonstrates the vitality utilization regarding unit devoured by the customer.

Electricity Board Side:-

It incorporates ZigBee module and Personal Computer System associated with server. This end shows what number of units devoured by the buyer, theft status, control status (ON/OFF), current bill as indicated by units expended, pending bill status, and so on. Toward the end Monthly bill status will be send to purchaser alongside the points of interest talked about before. Power changed to off when any robbery is identified or client did not paid his/her bill after due date is passed. This correspondence happens remotely by means of ZigBee module.

.Hardware and software Requirement:-

Automatic electricity bill generation and theft detection requires following hardware components:-

1. LPC2148 microcontroller
2. ZigBee module
3. GSM
4. Voltage Sensor and current sensor
5. LCD display
6. Relay
7. Real Time Clock (RTC)

Hardware and software Description-

1. ZigBee module:- Information correspondence is finished by utilizing IEEE 802.15.4 ZIGBEE has low power utilization with substantial lifetime batteries. Distinctive highlights are minimal effort, low power and work sort remote system, high dependability with extensive scope of operation. Request of different low power gadgets of remote systems administration is satisfy by ZigBee.
2. GSM:- Global System for Mobile communication is a digital mobile telephony system that is widely used in different parts of the world. GSM digitizes and compresses data, each in its own time slot.

3. LPC2148 microcontroller:- LPC2148 is the widely used IC from ARM-7 family. It is manufactured by Phillips and it is pre-loaded with many inbuilt peripherals making it more efficient and reliable option for the beginners as well as high end application developer. 8 to 40 kB of on-chip static RAM and 32 to 512 kB of on-chip flash program memory.
4. LCD display :-A liquid crystal display (LCD) is a thin, flat panel used for electronically displaying information such as text, images, and moving pictures. It is lightweight and portable.
5. Relay:- A relay is an electrically operated switch. Relays are used where it is necessary to control a circuit by a low-power signal or where several circuits must be controlled by one signal.
6. Real Time Clock (RTC):-A real time clock(RTC) is a computer clock that keeps track of the current time. Although the term often refers to the devices in personal computers, servers and embedded systems, RTCs are present in almost any electronic device which needs to keep accurate time.

## II. LITERATURE SURVEY

1. Title: Low Cost Electricity Meter Reading System using GSM

2. Description: The proposed framework concentrates on improvement of low power and ease electric vitality meter peruser. The framework comprises of two modules, estimation and correspondence module. Current transformer (CT) detects the line current while the potential transformer (PT) measures the line voltage. The yields, acquired from CT and PT, are present to voltage changed over, redressed, separated, constricted and simple to advanced changed over. The vitality is summation of the power utilized over a known timeframe. The measure of vitality is transmitted to Power provider and also purchaser by means of SMS at predefined interims.

1. Title: ZigBee Based Monitoring Theft Detection and Automatic Electricity Meter Reading

2. Description: Presently a-days power meter perusing also, charging is led physically by way to-entryway framework. This framework, as watched requires a huge measure of labor and is additionally devours time and vitality. To defeat the restrictions of this conventional framework, proposition of a model module which incorporates propelled remote innovation called "ZIGBEE". The proposed module diminishes the time postponement, mistakes and burglary of power. The ZigBee is favored over different remote advances

since it does not requires fast information rate, additionally this gadget is low fueled and minimal effort.

1. Title: Automatic Electricity Meter Reading Based on Image Processing
2. Description: This paper presents a framework in light of picture preparing to get proficiently and precisely perusing of the power advanced meter. In this framework the back camera of the cell phones is utilized to gain the picture of the power meter. The framework at that point applies a grouping of picture handling capacities to consequently extricate and perceive the digits of the meter perusing picture.

This picture experiences three fundamental stages: preprocessing which winds up with editing the numeric perusing zone, division of individual digits utilizing flat and vertical filtering of the trimmed numeric territory, and acknowledgment of the perusing by contrasting each divided digit and the digits formats. The proposed framework is actualized utilizing Android Studio programming. The proposed framework will be utilized as a part without bounds to build up a portable application that could be utilized by the power organization workers to encourage the perusing process.

1. Title: Automation of Electricity Billing Process
2. Description: In this paper region is chosen for the vitality supplier representative to take the meter perusing as far as preview of meter and present these photographs to the primary office which are utilized to peruse the readings and appropriately charge is produced however in this entire procedure because of human mediation precision isn't accomplished. For this reason AMR (Automatic Meter Reading) idea is produced in which programmed accumulation of readings, transmission and sending bill to client is done effortlessly. Camera is settled before vitality meter of each house will catch the picture of meter when it motivates order to catch and send this picture to vitality supplier office remotely where it experiences preprocessing and acknowledgment of digits which are additionally utilized for age of bill. This bill is again send to the individual meter proprietor as a back rub utilizing GSM module.

**III. MOTIVATION**

1. To detect theft in electricity
2. To generate electricity bill automatically and securely
3. To overcome the labor work

**IV. OBJECTIVES AND GOALS**

1. The main goal is to securely generate electricity bill automatically
2. To detect theft in electricity.
3. To overcome paper work.
4. To give daily updates to consumer.

**V. PROPOSED SYSTEM**

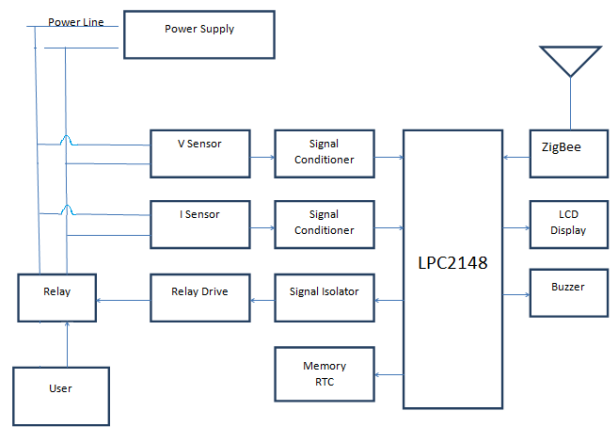

Fig 1. proposed User end system

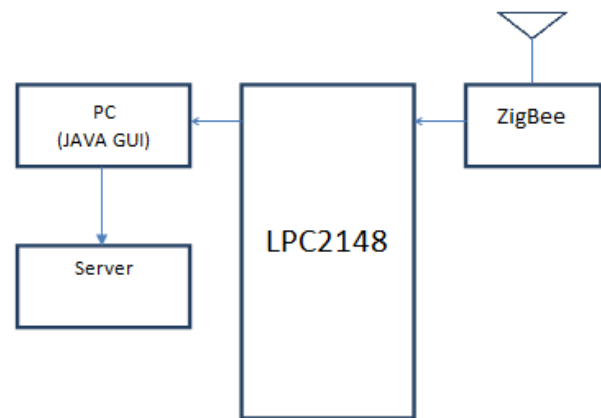

Fig. 2. Working of Distribution end system

**Actual Working:-**

When power supply is provided to the system voltage sensor checks the load and current sensor checks the flow of current. If loop gets completed we consider that its normal flow but if loop does not get completed then we can say that there is fraud in electricity. When flow of electricity is normal each unit is stored in EEPROM and displayed on LCD. Relay is used to cut power supply if any theft is detected or due date

of billing is passed. ZigBee is used to receive and transmit data. Buzzer is used as alarm when theft is detected. All the data will be stored in database and from there authority will send message or email to the consumer based on its meter ID. Consumer also notify about theft in electricity and due date of billing. Only the authority have the right to restore the connection.

**VI. FUTURE SCOPE**

1. Programmed meter perusing and charging in LPG gas.
2. Programmed meter perusing and charging in water administration.
3. Online installment can be connect up with this framework

**VII. CONCLUSION**

In the present time everything is getting to be noticeably computerized and remote innovation. In this period we are utilizing conventional vitality meter that requirements more labor and precision is less. By actualizing this framework we will have the capacity to identify robbery in power and can produce power charge naturally and safely. Supply cut by this framework must be reset by approved individual of the power office hence this framework decreases the manual mistake and give a phenomenal approach to identify the bypassing of the vitality meter.

**VIII. RESULTS**

- CONSUMER SIDE BOARD :

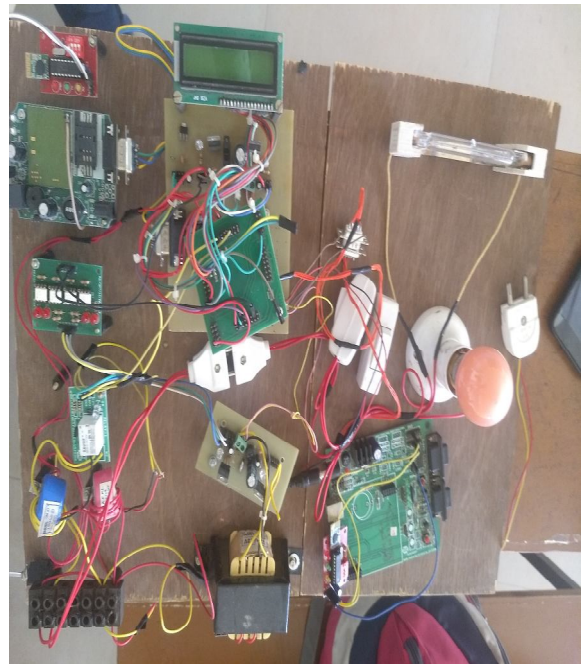

- ELECTRICITY BOARD SIDE

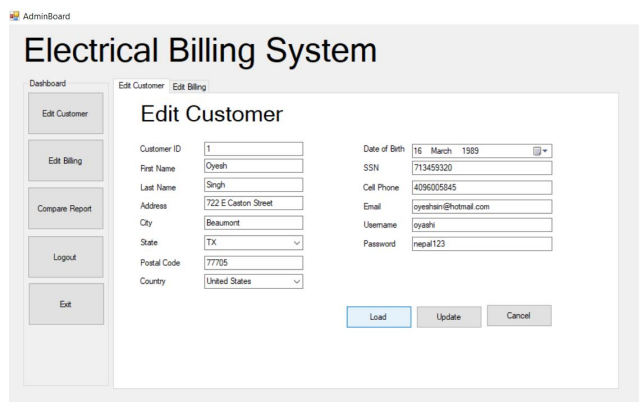
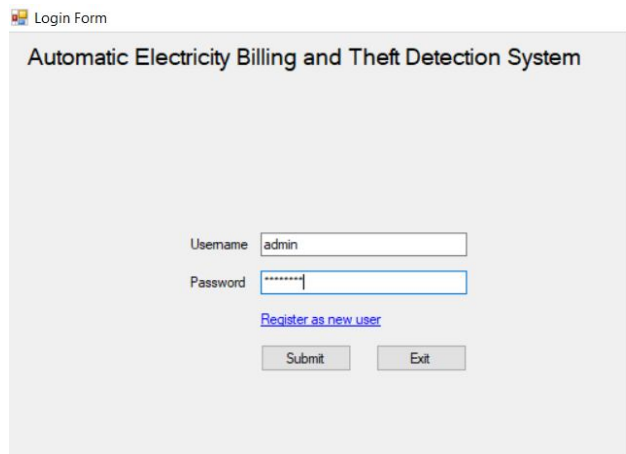

## REFERENCES

- [1] Muhamad, M., Zaman, H.B., Ahmad, A.: Virtual laboratory for learning biology – a preliminary investigation. *World. Acad. Sci. Eng. Technol.*6(71), 775–778 (2010)
- [2] Cook, D.A.: Web-based learning: pros, cons and controversies. *Clin. Med.*7,37–42 (2007)
- [3] McCormick, B.H., DeFanti, T.A., Brown, M.D.: Visualization in scientific computing (1987) *Virtual Labs Improve Student’s Performance in a Classroom* 145
- [4] Subramanian, R., Marsic, I.: ViBE: virtual biolog experiments (2001)
- [5] Diwakar, S., Parasuram, H., Medini, C., Raman, R., Nedungadi, P., Wiertelak, E.,Srivastava, S., Achuthan, K., Nair, B.: Complementing neurophysiology education for developing countries via cost-effective virtual labs: case studies and classroom scenarios.*J. Undergrad. Neurosci. Educ.*12, A130–A139 (2014)
- [6] O’Donoghue, J., Singh, G., Dorward, L.: Virtual education in universities: a technological imperative. *Br. J. Educ. Technol.* 32, 511–523 (2001)
- [7] Wentling, T.L., Park, J.-H.: Cost analysis of E-learning a case study of a university program. In: *Proceedings of the AHRD*, pp. 1–11. University of Illinois at Urbana-Champaign (2002)