

# Industry Automation Using IOT

Kunal D. Patil<sup>1</sup>, Niket N. Patil<sup>2</sup>, Majid S. Dangre<sup>3</sup>, Nilesh S. Thorat<sup>4</sup>

<sup>1</sup>Assistant professor, Dept of Electronics and Telecommunication Engineering

<sup>2,3,4</sup>Dept of Electronics and Telecommunication Engineering

<sup>1,2,3,4</sup>Nanasaheb Mahadik College of Engineering, Peth, India

**Abstract-** This paper provides a low cost-effective and flexible home control and monitoring system with the aid of an integrated micro-web server with internet protocol (IP) connectivity for access and to control of equipment and devices remotely using Android-based Smartphone app. The proposed system does not require a dedicated server PC with respect to similar systems and offers a new communication protocol for monitoring and controlling the home environment with more than just switching functionality. Smart home interfaces and device definitions to ensure interoperability between Wi -fi devices from various manufacturers of electrical equipment, meters and smart energy enables products to allow manufactured. In this project gives the intelligent operation for lamps and fans. .

The proposed home energy control systems design intelligent services for users and provides, The proposed system are implemented with smartphone.

**Keywords-** Wi-fi, Arduino, Home Automation, Android, Smartphone.

## I. INTRODUCTION

IOT or internet of things is a technology that deals with bringing control of physical devices over the internet. Here we propose efficient industry automation system that allows user to efficiently control industry appliances/machines over the internet. For demonstration of this system we use 3 loads as industrial appliances or machines and a motor to demonstrate as an industrial motor.

Our system uses an AVR family microcontroller for processing all user commands. A WIFI modem is used to connect to the internet and receive user commands. On sending commands through the internet they are first received by our WIFI modem. The modem decodes information and passes it to the microcontroller for further processing.

The Microcontroller then switches loads and operates the motors as per Receivers commands. Also it displays the system state on an LCD display. Thus we automate entire industry using online GUI for easy industry automation.

## II. IDENTIFY, RESEARCH AND COLLECT IDEA

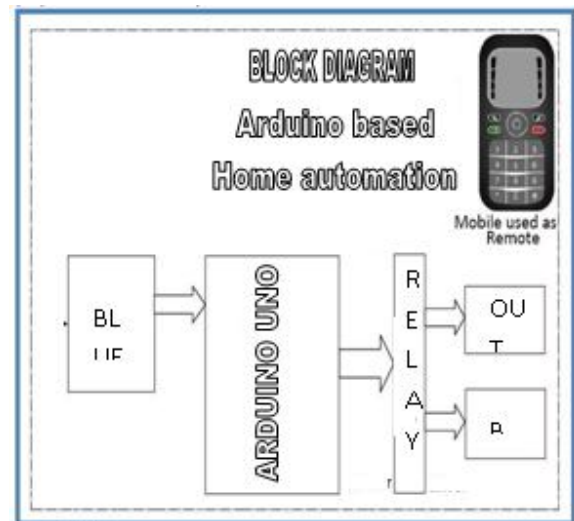

Fig 2:- Home Automation using Bluetooth

Home Automation Using Bluetooth:-

Bluetooth is a wireless technology for transferring data between two devices that are in close proximity; it is most suitable for short timed communications. Bluetooth communication technology does not require line of sight between the two communicating nodes. Thus, making it a viable option for home appliance control over the traditional remote control. In the authors developed „PICONET“, which basically is a network of Bluetooth devices. The authors made use of a master-slave connection between several devices. The control or central Bluetooth module is attached to a microcontroller chip which serves as the master device while the slaves are the modules attached to the various appliances. An android phone was used as the mobile unit and commands were issued via the Bluetooth application on it. The microcontroller was set in a polling status and constantly checks any input command every 500 millisecond from the Android phone application. The use of master-slave structure ensured that existing structures are not tampered with and scalability becomes easy.

**III. PROPOSED BLOCK DIAGRAM**

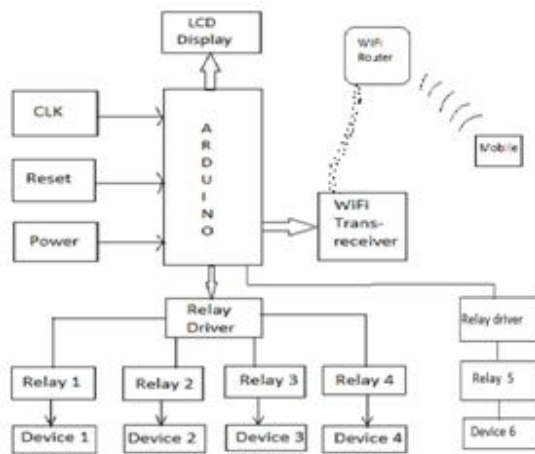

Fig 3:-Proposed Block Diagram of Industrial Automation using IOT

In this Block diagram which require +12V & +5V (DC)supply, to fulfill this requirement we have used following circuit of power supply which provides regulated +12V & +5V.(DC)

4 diodes (IN4007) are connected to secondary of transformer in bridge for rectifying AC into DC. Capacitor 1000 mf & 1mf are used as a filter red led shows that rectification and filtering is ok.

7805 IC is used as a 5V regulator it converts 12V into regulated +5V DC green led shows that output of 7805 is ok. Arduino UNO :-

Arduino/Genuine Uno is a microcontroller board based on the ATmega328P. It has 14 digital input/output pins (of which 6 can be used as PWM outputs), 6 analog inputs, a 16 MHz quartz crystal, a USB connection, a power jack, an ICSP header and a reset button. It contains everything needed to support the microcontroller; simply connect it to a computer with a USB cable or power it with a AC-to-DC adapter or battery to get started.. You can tinker with your UNO without worrying too much about doing something wrong, worst case scenario you can replace the chip for a few dollars and start over again.

"Uno" means one in Italian and was chosen to mark the release of Arduino Software (IDE) 1.0. The Uno board and version 1.0 of Arduino Software (IDE) were the reference versions of Arduino, now evolved to newer releases. The Uno board is the first in a series of USB Arduino boards, and the

reference model for the Arduino platform; for an extensive list of current, past or outdated boards see the Arduino index of boards.

**IV. FLOW CHART**



Fig 4:- Workflow of Proposed System

**V. COMPONENTS USED IN THE PROPOSED SYSTEM**

WiFi Module:-

This is ultra low cost module that is easy to use and reliable based on ESP8266 chipset to be used along with a microcontroller that configures and communicates through AT commands.

Till now embedded Wi-Fi solutions was a bit pricey to implement for hobbyist. This module is changing the trend rapidly. It gives excellent working range and opening wide array of applications.

Applications

- Internet of Things (IoT)
- Wireless Remote Control
- Wireless Sensor Networks
- Web Server / Client
- Wireless UART

Relay Driver IC ULN 2803:-

The board has four relays driven by ULN2803 IC. The board works on 12V but the input signal can come directly from microcontroller output working at 3V or 5V to control relays. Each relay can switch variety of AC or DC high voltage, high current loads working at 110V or 220V AC mains like lights, fans, motors and such. The status of relay is indicated by individual LEDs.

**RELAY:-**

A relay is an electrically operated switch. Many relays use an electromagnet to operate a switching mechanism mechanically, but other operating principles are also used. Relays are used where it is necessary to control a circuit by a low-power signal (with complete electrical isolation between control and controlled circuits), or where several circuits must be controlled by one signal.

**VI. CONCLUSION**

Industry automation system will bring more convenience and comfort to people's life. The android-based smart industry application communicates with the Wi-Fi module ESP8266 which acts as an access point. Using android application user could control and monitor the industry environment. Arduino provides an economic and efficient platform to implement the Industry automation system. This system can be used to communicate with many numbers of devices. It minimizes the wastage of electricity and it consumes less time, also it helps the old aged and disabled people in doing the basic domestic works on their own.

**VII. ACKNOWLEDGMENTS**

While presenting a project, a person gets a lot of knowledge and experience. A successful project could be not completed without inspiration and guidance held from different people.

We have great pleasure to express our sense of gratitude to our guide Mr. K. D. Patil for his valuable and encouraging guidance in all phases of project work. He has been always source of inspiration to use and we are highly thankful for his kind help.

We also express our sincere thanks to Mr. P. D. Desai (Head of Electronics & Telecommunication Department), all teaching and non teaching staff and friends who have helped us for completing our project work.

**REFERENCES**

- [1] Smart Industry System Using Android Application- R.A.Ramlee, M.A.Othman, M.H. Leong<sup>1</sup>, M.M.Ismail, S.S.S.Ranjit
- [2] Android Based Security And Remote Surveillance SystemMenthol Kumar
- [3] Home Automation and Security System Using Android ADKDeepali Javale.

- [4] Android Based Industry Automation Using Raspberry Pi-Shaiju Paul
- [5] Smart Home Automated Control System Using Android Application and Microcontroller-Mohammad Abd Al Latif Mowad