

# Design And Analysis Of Intelligent Braking System

Prof. Chetanraj Patil<sup>1</sup>, Anup P. Mankar<sup>2</sup>, Onkar H. Pawar<sup>3</sup>, Mahesh R. Mahajan<sup>4</sup>, Ashish N. Nemade<sup>5</sup>

<sup>1</sup>Assistant Professor, Dept Of Mechanical Engineering,

<sup>2,3,4,5</sup> Student Dept Of Mechanical Engineering,

<sup>1,2,3,4,5</sup> DIT, Pimpri, Pune

**Abstract-** Braking is nothing but bringing a moving vehicle or moving body to a stop. Nowadays safety is an important feature in the automotive industry. The intelligent braking system is the next step to automation. Presently cars have the alarm system where the car gets too close to an object, an alarm is triggered which warns the driver about an object close by. But this feature has produced lot of problems and are prone to human error. We have enhanced the facility by using the same system but we have altered it so that the car brakes automatically when an obstacle is close by. The aim is to design and develop a control system based on intelligent electronically controlled automotive braking system is called “INTELLIGENT BRAKING SYSTEM”. Sensor Operated Pneumatic Brake consists of IR transmitter and Receiver circuit, Control Unit, Pneumatic breaking system. The IR sensor is used to detect the obstacle. There is any obstacle in the path, the IR sensor senses the obstacle and giving the control signal to the breaking system. The pneumatic breaking system is used to brake the system. So basically here the car brakes on its own by determining the distance from the object.

**Keywords-** Infrared Sensor, Microcontroller, Receiver, Pneumatic Cylinder, Brake pedal, Solenoid Valve, Obstacle.

## I. INTRODUCTION

We have pleasure in introducing our new project “INTELLIGENT BRAKING SYSTEM”, which is fully equipped by IR sensors circuit and Pneumatic breaking circuit. It is a genuine project which is fully equipped and designed for Automobile vehicles. This forms an integral part of best quality. The “PNEUMATIC BRAKING CIRCUIT” can stop the vehicle within 2 to 3 seconds running at a speed of 50 KM. The intelligent braking system is a fully automated.

This is an era of automation where it is broadly defined as replacement of manual effort by mechanical power in all degrees of automation. The operation remains an essential part of the system although with changing demands on physical input as the degree of mechanization is increased.

Degrees of automation are of two types,

- Full Automation
- Semiautomation.

In semi automation a combination of manual effort and mechanical power is required whereas in full automation human participation is very negligible.

## II. LITERATURE REVIEW

Prof. A. P. Thakare, There have been considerable advances braking systems in recent years. Designers have proposed several enhancements range radar system was developed for anti applications where automatic braking is applied in response to detection of a collision risk where a very high probability of detection is accompanied by a very low level of false alarms. A brake strategy for an automatic parking system of vehicle has proposed brake controller which work with the automatic parking system and make the process of parking smooth and stable. Autonomous antilock braking system (ABS) system which can take over the traction control of the vehicle is developed for a four wheel vehicle.

Dragan Aleksendric, Intelligent modeling, prediction and control of the braking process are not an easy task if using classical modeling techniques, regarding its complexity. In this paper, the new approach has been proposed for easy and effective monitoring, modeling, prediction, and control of the braking process i.e. the brake performance during a braking cycle. The context based control of the disc brake actuation pressure was used for improving the dynamic control of braking process versus influence of the previous and current values of the disc brake actuation pressure, the vehicle speed, and the brake interface temperature.

Mr. Tushar Kavatkar<sup>1</sup>, The braking system was designed and applied on a car to make the driving process safety using embedded system design. Most of the accident occurs due to the delay of the driver to hit the brake, so in this project work braking system is developed such that when it is active it can apply brake depending upon the object sensed by

the ultrasonic sensor and speed of vehicle. Currently, vehicles are often equipped with active safety systems to reduce the risk of accidents, many of which occur in the urban environments.

**III. PROBLEM STATEMENT**

Now-a-days, accident prevention is the major sector of research. We are seeing the most of accidents, occurred due to drivers mistake. To avoid that mistake, some arrangements are needed to help driver in critical condition. So, Intelligent Braking System is such type of system which applies brake without the permission of driver by sensing the obstacle in the given path and helps to avoid accidents. Intelligent Braking System is introduced for providing safety and comfort to driver during driving. The main aim of the system is avoid damage of life and property.

**IV. DESIGN OF INTELLIGENT BRAKING SYSTEM**

In design method, firstly we understand the problem statement. Then we find various solutions to overcome the problem and how to automize the operation.

The difficult task of designing is that to design the various component of pneumatic circuit, then on that basis we made conceptual rough drawing of machine. Then we discussed the drawings with our guide and at the end, we finalize the design through catia software.

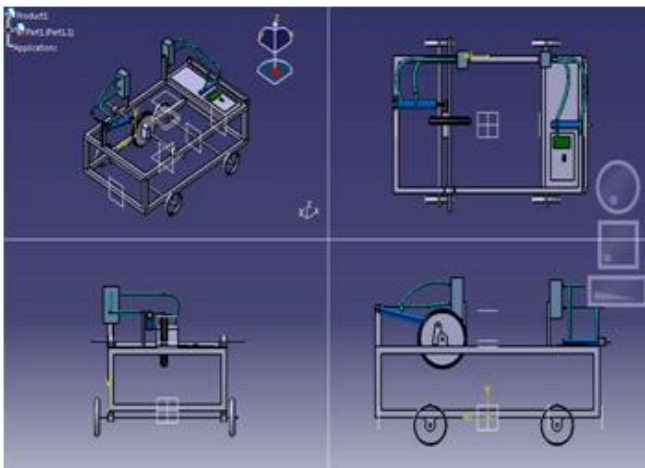

**V. CALCULATIONS ON STOPPING DISTANCE**

The total stopping distance of a vehicle is made up of 4 components. They are, Human Perception Time Human Reaction Time Vehicle Reaction Time and Vehicle Braking Capability The human perception time is how long the driver takes to see the hazard, and the brain realize it is a hazard

requiring an immediate reaction. This perception time can be as long as ¼ to ½ a second.

Total stopping distance = Human perception distance + human reaction distance + braking distance + distance covered in 1sec

Braking Distance,

$$D_{braking} = v^2/2\mu g \text{ (m)}$$

Where,

v = Velocity before applying brakes

μ = coefficient of friction = 0.7 (for dry surfaces)

g = acceleration due to gravity (9.81m/s<sup>2</sup>)

Speed Of Vehicle in km/hr	Speed In m/s	Stopping Distance
10	2.777	0.6617
20	5.55	2.2472
30	8.333	5.0563
40	11.1111	8.9891

**VI. FUTURE SCOPE**

IBS is introduced for providing safety and comfort to driver during driving. The main aim of system avoids the accidents. Most of the time driver is unable to judge proper distance between car and obstacle, so the system will be helpful as well as important in car safety. This is the new idea in automobile industries to make human life more comfortable. This system is regular safety system and increases the comfort of human being. A new technology from volvo may launch which allow cars to park automatically. Recently, Volvo has announced its working automatic parking system dubbed autonomous parking. It uses sensor system to park the vehicle without driver.

**V. ACKNOWLEDGEMENT**

We express our sincere thanks to our Guide Prof. Chetanraj Patil for their constant encouragement and support throughout our project, especially for the useful suggestions given during course of the project period and having laid down the foundation for the success of this work.

We would like to thank our project co-ordinator for his assistance, genuine support and guidance from early stages of project.

We would also like to thank you Dr. K.K. Dhande, Head Of Mechanical Department for his unwavering support during entire course of the project work.

We would also thank to our staff members of our college and technicians for their help in making this project successful. Finally, we take this opportunity to extend our deep appreciation to our family and friends, for all they meet to us during the crucial times of the completion of the project.

### REFERENCES

- [1] Hardware Implementation of Intelligent Braking System” Published By - S. N. Sidek and M. J. E. Salami, Faculty of Engineering, International Islamic University Malaysia.
- [2] Intelligent Mechatronic Braking System” Published By - G.V. Sairam, B. Suresh, CH. SaiHemanth, K. Krishna sai
- [3] Lennon,W.K., and. Passino,K.M . ” Ieee Transaction On Control System Technology”, VOL.7, NO.2, 1999
- [4] Jadhav Snehal Dnyandeo1, Taware Tejashree Brahmadeo2, and Jadhav Shamal popatrao3, VEHICLE CONTROL SYSTEM USING CAN PROTOCOL. International Journal of Engineering Research and General Science Volume 3, Issue 3, May-June, 2015.
- [5] A precise short range radar for anti-collision systems with automatic braking," Consumer Applications of Radar and Sonar, IEE Colloquium.<http://ieeexplore.ieee.org>