

Protection For HVDC Transmission Line System Based on VSC

Abhay Pratap Singh

Poornima College Of Engineering

Abstract- Growing populations among many countries around the world today are forcing resources to be more stretched. As the population grows, these nations need more land, not to mention adequate electrical, water and communication services.

This paper presents some new technologies of voltage source converter (VSC), i.e., modular multilevel VSC, for high voltage direct current transmission system based on VSC (VSC-HVDC). The origin of modular multilevel VSC and its essential working mechanism are clarified in detail. Then, the effective protection measures of submodule and the technology of controlled submodule capacitor voltages balancing are discussed. And the capacitance installed in each submodule is calculated.

ABB pioneered HVDC technology and is a world leader in the field. In total, around 140 GW of HVDC transmission capacity is installed in some 145 projects worldwide.

Keywords- HVDC transmission based on VSC (VSC- HVDC), modular multilevel VSC, new technologies, power sums theory, protection measures, Voltage Source Converter (VSC)

I. INTRODUCTION

HVDC Schemes using Voltage-Sourced Converter (VSC) technology (such as ABB's HVDC Light) are becoming increasingly prevalent, especially at power ratings up to 1000MW. This paper aims to consider the physical site impact of the choice between LCC-HVDC and VSC-HVDC, with all other factors assumed to be equal. Generation 3 and Generation 4 of the ABB's HVDC Light technology are considered in this comparison.

VSC-HVDC is considered as new flexible control technologies to improve power system performance. Active and reactive powers of the VSC-HVDC can change rapidly within its capability curve and be controlled independently. This is a very interesting feature of this technology to modulate the power flow in the system and support the power system with the best mixture of active and reactive powers during stressed conditions to improve voltage stability

Currently, all of the installed VSC-HVDC systems are either back-to-back converters or are connected through underground cable. No overhead DC lines have been installed as of yet. It is said that the absence of overhead DC greatly reduces the risk of DC faults. However, in the case of a cable-connected system, a ground fault is almost always permanent, either by the failed cable insulation or the cable damage by an outside source. As more of these systems are installed into the bulk power system, protection of the VSC-HVDC systems must be a priority. VSC-HVDC systems are, by design, vulnerable to faults on the DC systems. Classical current-sourced-converter- based (CSC) HVDC naturally are able to withstand short circuit currents due the DC inductors limiting the current during fault conditions. When a fault occurs on the DC side of a VSC-HVDC system the IGBT's lose control and the freewheeling diodes act a bridge rectifier and feed the fault, as shown in Fig. 1. The types of faults possible on a HVDC system are as follows.

- Positive line to ground fault
- Negative line to ground fault
- Positive line to negative line fault
- Overcurrent

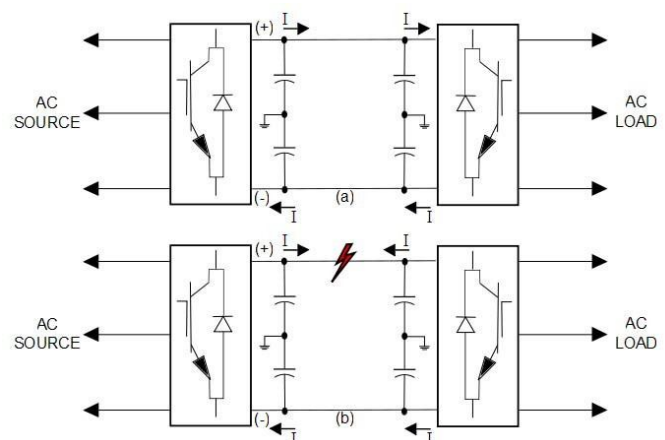

Fig. 1. VSC Operation (a) Normal. (b) Positive Line-to-Ground Fault

II. POSSIBLE FAULTS

2.1 Line-to-Ground

A line-to-ground fault (ground fault) occurs when the positive or negative line is shorted to ground. In overhead lines faults may occur when lightning strikes the line. This may cause the line to break, fall to the ground and create fault. In this situation the fault is always permanent and the line must be isolated for repair. Ground faults may also occur by objects falling onto the line, such as trees, providing a path to ground. In some cases when an object causes the ground fault it may fall away from the line and the system can be restored. If the fault persists the line would have to be taken out of service until the fault path can be cleared.

Underground cable is almost completely immune to line-to-line faults, as insulation, conduit and the earth separate the cables. However, they can still occur. The insulation of the cable can fail due to improper installation, excessive voltage/current, exposure to the environment (water, soil, etc) or cable aging. When this occurs, the broken insulation will allow a path for current to flow to ground. As the fault persists the integrity of the insulation is reduced causing the fault to worsen. A ground fault may also occur when a person inadvertently cuts through one of the lines. This can happen during construction projects. In either case the fault will always be permanent and will require a complete shutdown of the line as well as a costly repair.

When a line-to-ground fault occurs, the faulted pole rapidly discharges capacitor to ground. This causes an imbalance of the DC link voltage between the positive and negative poles. As the voltage of the faulted line begins to fall, high currents flow from the capacitor as well as the AC grid. These high currents may damage the capacitors and the converter

2.2 Line-to-Line

As stated before, a line-to-line fault on a cable-connected system is less likely to occur on the cable. In an overhead system, line-to-line faults can be caused by an object falling across the positive and negative line, they may also occur in the event of the failure of a switching device causing the lines to short. A switching fault, which is independent of how the converter stations are connected together, causes the positive bus to short to the negative bus inside the converter. A line-to-line fault may be either temporary or permanent.

2.3 Overcurrent

While overcurrent protection is important during line-to-line and line-to-ground faults, it must also operate when the system is being overloaded. Overload conditions may occur in two-terminal systems when the load increases

past the rating of the converter or as a result of a fault on another part of the system. For example, if three VSC's are feeding a common load and one VSC is dropped due to a permanent fault, the remaining two must supply the load. This will result in elevated currents that may overload the converters. In this situation the overcurrent protection would need to operate. Another option to avoid a wide spread blackout would be to shed non-critical loads.

2.4 Overvoltage

Overvoltages may occur in overload or in fault conditions. Overvoltages are only a concern during line-to-ground faults. When the fault occurs, the capacitor discharges rapidly to ground. The current flows through the ground then back to the unfaulted line and finally back to the source, which causes the voltage on the healthy pole to increase to 2 p.u.. Overvoltage is also a concern during the loss of a converter. The loss of an inverter can cause voltage spikes due to excessive power, quickly charging the DC link capacitors. A rectifier loss is only of concern when the loss is temporary.

When the rectifier returns suddenly it can cause overvoltages similar to that of an inverter loss.

Unbalanced AC network phases, mainly caused by faults, can lead to adverse effects on the operation of the VSC. The configuration of the transformer linking the VSC to the AC grid can affect the voltage level on the DC side under AC faults. It can be seen that when the VSC is connected in a Y/ Δ , that a ground fault on the AC can result in an overvoltage of 1.5 p.u.

III. DC PROTECTION WITH AC DEVICE

Protection of DC systems can be done with conventional AC devices such as circuit breakers and fuses. The advantages of using AC devices include:

- Less expensive than DC counterparts
- Shorter lead time
- Mature science
- More familiar devices
-

Below the methods of protection are shown

3.1 AC Circuit Breakers

Placing AC circuit breakers on the AC side of the VSC is the most economical way to protect the DC system. They are commonly available and can be replaced in a shorter amount of time. However, AC circuit breakers result in the

longest interruption time as a result of their mechanical restrictions. Currently, the best interrupting time for an AC circuit breaker is two cycles.

When using an AC circuit breaker, the voltage of the DC capacitors will be monitored as well as the current in each DC line at each converter. These values will be fed back to a standard relay, which will monitor over/undervoltage, as well as overcurrent. When a DC fault occurs, the capacitors will discharge rapidly causing the voltage to decrease. The current on the faulted line will increase over the rated value. Once the relay senses one or more of these conditions, it will trip the breaker. In an attempt to restore the system, the relay will enter a re-closing cycle in which the relay will close back in and sense the voltage and current of the DC system. If the fault is cleared the system will return to normal, but if a permanent fault is detected the relay will lock out the breaker. The relay identifies a permanent fault by the re-closing sequence. A typical industry standard for re-closing on AC systems is that two attempts will be made; this can be applied to the VSC systems as well. After two attempts without success, the relay determines that the fault is permanent and will not allow the breaker to close.

In back-to-back or two-terminal transmission systems, differential protection may be used to protect each converter, as shown in Fig. 3.1. The differential will measure the current entering the converter as well as the current leaving the converter. If the current entering does not match the current leaving the differential relay, it will trip the AC breaker. In back-to-back systems one relay could also monitor the AC current at the sending VSC as well as the receiving VSC. If the current at one end does not match the current at the other end, the relay would know a fault has occurred and the VSC's would be tripped offline. In a two terminal transmission system, two relays would be required and the current readings would have to be sent to the other relay via communication as can be seen in Fig. 3.2. This type of differential protection is common in AC systems as could be applied to VSC protection. Also, compensation for losses would have to be taken into account.

While AC circuit breakers are inexpensive, easy to use, and widely used, they also shut down the entire converter. This is problematic in the case of ground faults where the faulted line could be isolated and the system could run monopolar using ground as a return path. AC circuit breakers are also inconvenient in multi-terminal systems, which will be discussed later

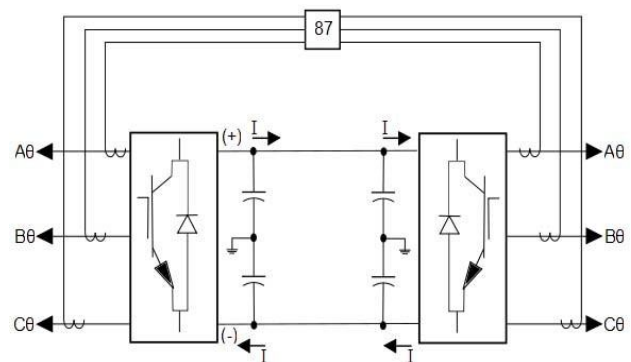

Fig. 3.1 Back to Back Differential Protection

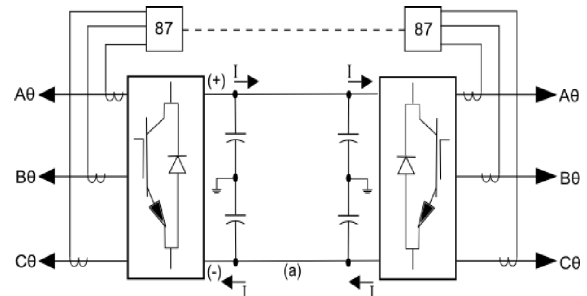

Fig. 3.2 Two-Terminal Differential Protection

2.5 Fuses

Fuses on the AC side are generally not a good solution for protection of the VSC. This is because a fuse is a thermal device that is only allowed one operation. Fuses do not have the ability to distinguish whether a fault is temporary or permanent. To a fuse every fault is permanent and therefore the system would not be able to be restored until the fuse was physically replaced. The only place that a fuse may be an acceptable alternative is for a non-critical load, or in areas where space is limited, such as a ship. Fuses are used for protection, but are mainly for AC protection and other DC devices protect the DC line. The DC devices coordinate with the fuse such that they will trip before the fuse. The fuse will only operate in the event that the DC protection fails.

Overall, fuses should be used only when necessary and all other options are not possible.

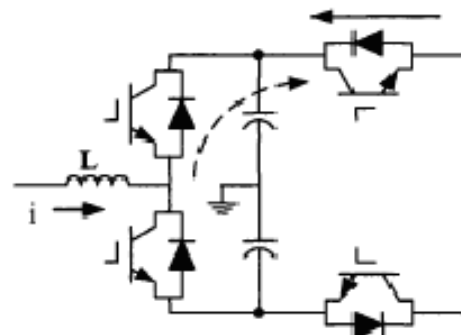

Fig. 3.3. IGBT-CB Fault Blocking Capabilities.

IV. DC PROTECTION WITH DC DEVICES

While AC devices are an economical way to protect the DC system, DC devices are a better option whenever possible. DC protective devices can act faster than their AC counterparts, as well as sectionalize lines. This allows the operation of unfaulted lines to continue. The methods of protection using DC devices are shown below.

4.1 IGBT Circuit Breakers

An IGBT circuit breaker (IGBT-CB) utilizes the blocking capability of the solid-state device. Like the other IGBTs in the converters, the IGBT-CBs are configured with an anti-parallel diode. The only drawback to the IGBT-CB is that it is a uni-directional device. This is illustrated in Fig. 4.1. When a fault occurs on the DC line, the IGBT is able to block the fault current (represented by the dashed line in Fig. 4.1). If the fault occurs on the converter side, the anti-parallel diodes conduct and allow current to flow (represented by the solid line in Fig. 4.1). In this scenario the IGBT-CB must rely on the blocking of the IGBTs in the converter.

For two-terminal systems, IGBT-CBs can be placed at each converter station, one on the positive line and one on the negative line, as can be seen in Fig. 4. Fast acting DC switches are used in conjunction with the IGBT-CB, which is used to isolate the line once the fault current has been cleared. It should be noted that the switch cannot break current and may only be opened once the fault has been extinguished. As with AC, the DC current of each line and the DC voltage of each capacitor will be sensed. Once the control system senses a fault on the line, an appropriate IGBT-CB will receive a gate signal to block the current. Once the fault current has been extinguished the fast acting DC switches will open, isolating the line. To determine if the fault is temporary or permanent, the DC switches and the IGBT-CB will close. If the fault has cleared the system will return to normal operation. If the fault is still present, the line will be isolated again and a permanent fault will be determined.

The advantage of using an IGBT-CB is that the entire converter is not shutdown in the case of a ground fault. This

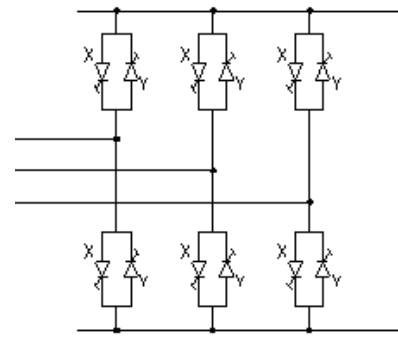

Fig. 4.1 ETO Based VSC-HVDC Converter

allows the faulted line to be isolated and have the system continue to run mono-polar. The IGBT-CB also opens faster than its AC counterpart. The disadvantage to the IGBT-CB is that it cannot protect against DC rail faults in the rectifier.

4.2 Converter Embedded Devices

Converter embedded devices are active, protective components that are installed inside a VSC to detect and isolate DC faults. This method eliminates the use of additional devices, reducing the footprint of the converter station and also possibly cutting cost. However, a redesign of the converter is required. The converter uses two Emitter Turn Off (ETO) devices in an anti-parallel configuration to achieve both switching and protection. The ETO has a higher voltage and current rating than IGBT. Fig. 4.2 illustrates the converter configuration. In normal operation the ETO's X act as the switching devices, while ETO's Y act as the anti-parallel diode, and are constantly fired on. In the event of a fault the ETO's X are blocked while ETO's Y continue to feed the fault. Once the fault has been identified as permanent the Y ETO's will be gated off.

Another protection method has replaced the typical IGBT and anti-parallel diode is a combination switching device with the submodule shown in Fig. 4.3. The converter submodule provides two different levels of protection. The first level protects the converter from being shutdown during a switching device failure. In the event of a switching device failure, the submodule will close switch K1, shorting out the defective submodule. This allows the converter to continue to operate by using redundant modules for un-altered system performance. The second level of protection reacts under fault conditions. As stated earlier, the switching device blocks and the anti-parallel diode conducts to feed the fault under fault conditions. The freewheeling diodes in VSC's are not able to withstand large surge currents, and may be damaged before the fault is cleared. The solution is to bypass the IGBT and the anti-parallel diode with a press-pack thyristor K2. The

proposed press-pack thyristor is able to withstand high surge currents, protecting the anti-parallel diode until the fault can be cleared.

This protection method allows the converter additional control and increases the current rating of the switching devices. It also cuts down on the number of components required for protection because the protection is embedded in the converter

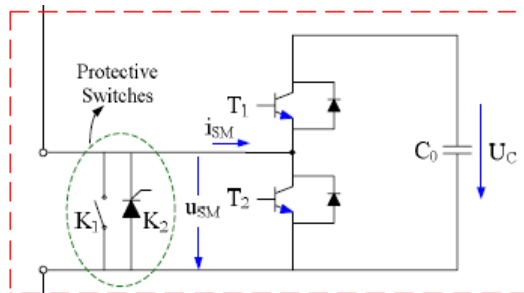

Fig. 4.2. VSC-HVDC Converter Submodule

The disadvantage is that the entire converter must be shut down in the event of a permanent fault. This works well in two-terminal systems but may cause problems in multi-terminal systems.

V. MULTI-TERMINAL SYSTEM PROTECTION

VSC-HVDC systems are very appealing in multi-terminal systems, as power flow can be changed not by voltage polarity but the direction of the current. The possible applications for multi-terminal VSC-HVDC (MT-VSC-HVDC) systems are used in renewable energy applications and in distribution of power in mega cities. The protection strategies for MT-VSC-HVDC utilize both AC and DC protection.

4.3 AC Protection

As stated previously, DC protection can be achieved by using AC circuit breakers on the AC systems. This strategy can be applied to MT-VSC-HVDC as well. A "hand shaking" method is proposed in. This method, in addition to using AC circuit breakers, implements fast acting DC switches. The switches are only used to isolate lines and cannot break load or fault current. Each VSC will receive current measurements from their respective DC switches. When a fault occurs all of the AC circuit breakers associated with the MT-VSC-HVDC system will trip. Next, each VSC must determine which one of its respective switches to open. This is done by measuring the magnitude and direction of the current through each switch. The switch that will be selected is the one with

the largest positive fault current. The hand shaking method defines positive as out of the node and negative into the node. Fig.5.1 illustrates the example system given in.

When a fault occurs on Line 1, VSC1 receives current measurements from SW11 and SW31. VSC1 senses that the current through SW11 is positive and the current through SW31 is negative. Through the hand shaking method VSC1 opens SW11. VSC2 receives current measurements from SW12 and SW22. Once again the current through SW12 is positive and the current through SW22 is negative and switch SW12 is selected. VSC3 receives current measurement from SW33 and SW23. The current direction for both switches is measured as positive. The switch with the highest magnitude of current is selected. At this point Line 1, the faulted line, is isolated, and Line 3 is open at one end. At this point the system must enter a re-closing mode. First, all of the AC

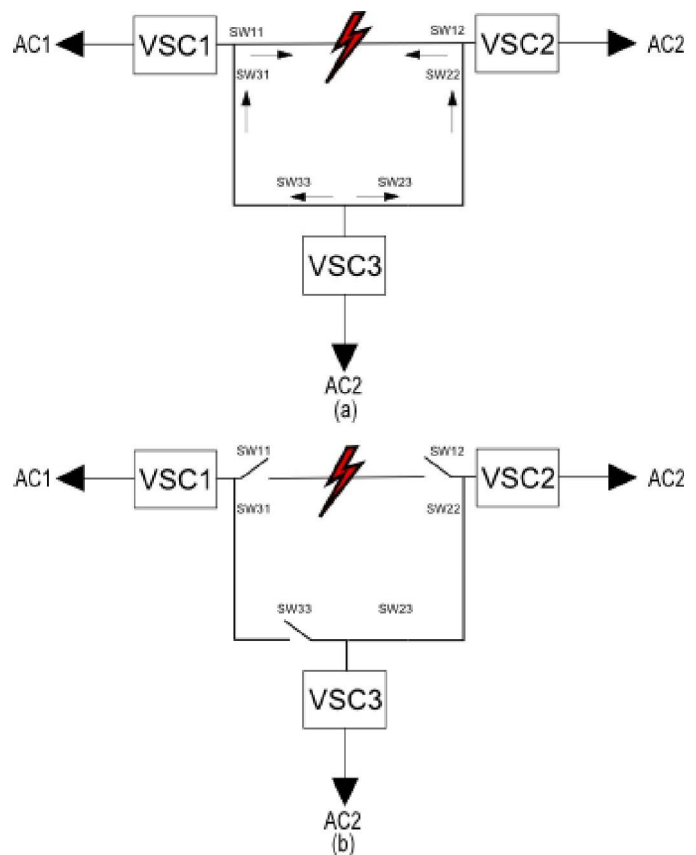

Fig. 5.1. (a) Current Flow During a Fault. (b) Fault Isolation with the Hand Shaking Method

breakers will close back in, re-energizing the VSC's. Next, the fast DC switches of the non-faulted DC lines must be closed. The VSC's only re-close switches when the voltage of its respective line is near the voltage of the VSC terminals. Fig. 8 shows the re-closing method presented in, where it can be seen that only SW33 will be able to re-close. During the

fault VSC1 chose to open SW11, leaving SW31 closed. Once the AC breakers re-close, and the VSC1 is back on line, Line 3 will recharge. VSC3 will sense the Line 3 voltage and allow SW33 to close. Both SW11 and SW12 will remain open as Line one was discharged during the fault and both VSC1 and VSC2 will sense no voltage on Line 1, therefore not allowing the switches to close.

4.4 DC Protection

DC Protection utilizes IGBT-CB's and fast acting DC switches. The IGBT-CB's can be placed at the terminals of each VSC or at the end of each line, as show in Fig.5.2.

The voltage of the capacitors will be monitored as well as the current through each line. When the current exceeds the maximum setpoint and the voltage begins to rapidly discharge the respective IGBT will begin to block and the fast acting DC switch will open once the fault is extinguished. This type of protection is very advantageous in MT-VSC-HVDC systems as you can isolate individual lines without interrupting the entire network. This is especially true in Fig. 5.1 (b) where each line has its own IGBT-CB. While this is a more effective

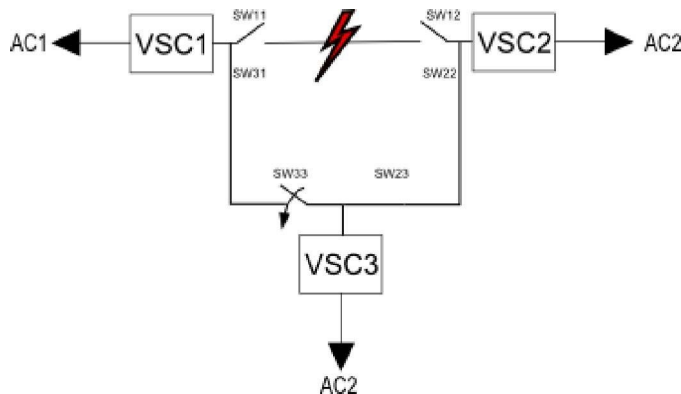

Fig. 5.2. Hand Shaking Method Re-Closing

method of protection, it is the most expensive option with further challenges. Unlike Fig. 5.1 (a) case, IGBT-CB cannot begin to block when a fault is detected on the positive line because two or more lines split from the positive or negative node. Since all lines that are connected to a particular node will feed fault on any other line connected to the same node, the faulted line must be detected. they are large current change, rise time, and oscillation pattern.

The large current change method determines which lines are faulted by comparing the current magnitude of all lines feeding the fault. The line with the largest current change in a given time will be chosen as the faulted line. The rise time method measures the rise time of the first wave front

of the current. When a fault is detected, each VSC will measure the rise time of the current in their respective lines. The line with the fastest rise time will be identified as the faulted line. The oscillation pattern method looks for wide pulses without a change in polarity. This identifies the faulted line.

While isolating the fault is important, limiting the amount of fault current is as well. The DC link capacitors contribute high fault currents in a very short amount of time. Typically, capacitor protection is done with snubber circuits. However, the snubber only limits the discharge rate of the capacitor; it does not interrupt the discharge current. The idea of placing a circuit breaker in series with the capacitor is introduced in. The type of circuit breaker chosen is a Capacitor DC Circuit Breaker (CDCCB). The advantage of using a CDCCB is speed: it is a very fast acting device, operating in approximately 10 seconds. This fast operation protects the capacitor from extreme stress and destruction. The voltage will hold because the capacitor does not discharge under fault conditions. This creates a shorter charging time when the VSC is put back on line.

DC protection devices not only protect against overcurrent, but they can also protect against overvoltage. If a converter is lost on an MT-VSC-HVDC system the voltage on the system will drop, but once the converter is back on line the voltage can overshoot. One method presented to mitigate this problem is the implementation of a chopper circuit.

VI. CONTROLLERS

The previous sections overviewed the devices that interrupt fault conditions. This section will cover the active controllers that will attempt to change the operation of the VSC's under fault conditions in order to keep the system running. Traditionally, a single controller will operate during steady state and fault conditions. where the proposed controller supplies the normal and protective gate trigger pulses. Another option is to implement a parallel controller. The parallel controller is proposed to mitigate overcurrents and overvoltages. Both a current and a voltage controllers can be provided in parallel configuration. Within each of the respective controllers, a steady state and a fault controller can be connected in parallel using PI controllers to regulate the current and voltage. Each is running during normal operation but depending on the condition of the system one will take control of the firing pulses.

Overload problems may be solved by implementing some techniques found in motor control. A two-terminal VSC-HVDC system can be looked at as a double-sided converter

feeding a motor. When power levels begin to exceed the contingency rating of the system the VSC-HVDC system can enter "regenerative braking mode," returning the power back to the AC grid. This is an alternative to using a chopper circuit as the energy is not dissipated, rather it is redirected.

As mentioned, the loss of a converter can lead to over-voltages in the system and can adversely affect MT-VSC-HVDC systems. To combat this problem an advanced DC voltage controller (ADCVC) is proposed in. This ADCVC operates in two stages; lower and higher hierarchical. The lower hierarchical control operates during normal system operation. This lower hierarchical controller is responsible for maintaining active power, reactive power and DC voltage. The higher hierarchical controller monitors the system and only reacts during transient disturbances, i.e., converter loss in MT-VSC-HVDC. The higher hierarchical controller recognizes transient disturbances by changes in the local voltage and current, as the loss of a converter will redirect power flow in the DC network. Upon recognition of a disturbance, the ADCVC will take control and alter the performance of its respective converter or shut down the converter in order to protect it from harm in some cases. The idea of lower and higher controllers is similar to coordination of protective

VII. CONCLUSION

If VSC-HVDC is ever to effectively compete with classical HVDC, protective devices must be implemented in the system. This paper has provided an overview of the existing proposed methods. Presently AC protection devices are widely in use for protection. AC side protection appears to be a good solution on two-terminal systems, but may cause unnecessary outages in multi-terminal systems. Converter embedded devices provide better and more versatile protection than AC side protection, but still cause complete converter shutdown in the event of a permanent fault. DC device protection provides the best form of non-active protection. DC devices operate faster than AC devices under fault conditions and allow for more flexibility in MT-VSC-HVDC systems. Controllers can provide good protection in terms of allowing the system to continue to operate under fault conditions. Ultimately, the best form of protection appears to be a combination of active controllers and DC devices. The controllers could allow for continuous system operation under temporary faults and the DC devices would take over isolating the fault if a permanent fault occurs. While it may not be the most economical and it increases the system complexity, it does provide better system protection. If by increasing the number of systems this combination of protective devices can be implemented, then the full potential of VSC-HVDC could be utilized resulting in a stronger and more reliable grid.

REFERENCES

- [1] X. Fu, K. Zhou, and M. Cheng, "Predictive current control of the VSC- HVDC system," *International Conference on Electrical Machines and Systems*, pp. 3892–3896, 2008.
- [2] A. Abbas and P. Lehn, "PWM based VSC-HVDC systems-a review," *Power & Energy Society General Meeting*, pp. 1–9, July 2009.
- [3] H. Chen, "Research on the control strategy of VSC based HVDC systems supplying passive network," *Power & Energy Society General Meeting*, pp. 1–4, October 2009.
- [4] C. Davidson and G. Prille, "The future of high power electronics in transmission and distribution power systems," *13th European Conference on Power Electronics and Applications*, pp. 1–14, 2009.
- [5] F. Schettler, H. Huang, and N. Christl, "Hvdc transmission systems using voltage sourced converters - design and applications," *Power Engineering Society Summer Meeting*, vol. 2, pp. 715–720, 2000.
- [6] B. Gemell, J. Dorn, D. Retzmann, and D. Soerangr, "Prospects of multilevel vsc technologies for power transmission," *Transmission and Distribution Conference and Exposition*, pp. 1–16, 2009.
- [7] L. Tang and B. Ooi, "Protection of VSC-multi-terminal HVDC against DC faults," *33rd Annual IEEE Power Electronics Specialist Conference*, vol. 2, pp. 719–724, November 2002.
- [8] N. Flourentzou, V. Agelidis, and G. Demetriades, "VSC-based HVDC power transmission systems: An overview," *Power Electronics Transaction*, vol. 24, no. 3, pp. 592–602, April 2009.
- [9] L. Tang and B. Ooi, "Locating and isolating DC faults in multi-terminal DC systems," *IEEE Transactions on Power Delivery*, vol. 22, no. 3, pp. 1877–1884, July 2007.
- [10] M. Baran and N. Mahajan, "Overcurrent protection on voltage sourced converter based multiterminal DC distribution systems," *IEEE Transactions on Power Delivery*, vol. 22, no. 1, pp. 406–412, January 2007.
- [11] W. Lu and B. Ooi, "Multi-terminal HVDC as enabling technology of premium quality power park," *Power Engineering Society Winter Meeting*, vol. 2, pp. 719–724, 2002.
- [12] J. Pan, R. Nuqui, K. Srivastava, P. Holmberg, and Y. Hafner, "AC grid with embedded VSC-HVDC for secure and efficient power delivery," *Energy 2030 Conference*, pp. 1–6, 2008.
- [13] J. Yang, J. Fletcher, and J. O'Reilly, "Multiterminal DC wind farm collection grid internal fault analysis

- and protection design,” *IEEE Transactions on Power Delivery*, vol. 25, pp. 2308–2318, October 2010.
- [14] H. Liu, Z. Xu, and Y. Huang, “Study of protection strategy for VSC based HVDC system,” *Transmission and Distribution Conference and Exposition*, vol. 1, pp. 49–54, September 2004.
- [15] N. Gibo and K. Takenaka, “Protection scheme of voltage sourced converter based HVDC systems under DC faults,” *Transmission and Distribution Conference and Exhibition: Asia Pacific. IEEE/PES*, pp. 1320–1325, 2002.
- [16] J. Yang, J. Zheng, G. Tang, and Z. He, “Characteristics and recovery performance of VSC-HVDC DC transmission line fault,” *Power and Energy Engineering Conference (APPEEC)*, pp. 1–4, April 2010.
- [17] G. Ding, G. Tang, Z. He, and M. Ding, “New technologies of voltage sourced converter (VSC) for HVDC transmission system based on VSC,” *Power and Energy Society General Meeting: Conversion and Delivery of Electrical Energy in the 21st Century*, pp. 1–8, July 2008.
- [18] W. Lu and B. Ooi, “DC overvoltage control during loss of converter in multiterminal voltage sourced converter based HVDC(M-VSC-HVDC),” *IEEE Transactions on Power Delivery*, vol. 18, no. 3, pp. 915–920, July 2003.
- [19] I. Etxeberria-Otadui, U. Viscarret, M. Caballer, A. Rufer, and S. Bacha, “New optimized PWM VSC control structures and strategies under unbalanced voltage transients,” *IEEE Transactions on Industrial Electronics*, vol. 54, no. 5, pp. 2902–2914, October 2007.
- [20] L. Tang and B. Ooi, “Managing zero sequence in voltage sourced converter,” *Industry Applications Conference*, vol. 2, pp. 795–802, December 2002.