

# Jumping Load Seismic Analysis Study of Multistorey Building

Dr. S. K. Deshmukh<sup>1</sup>, Dr. A. R. Gupta<sup>2</sup>, Mr. H. D. Anandani<sup>3</sup>

<sup>1,2,3</sup> Department Of Civil Engineering

<sup>1,2,3</sup> C.O.E.T., Akola, Maharashtra, India

**Abstract-** For seismic evaluation of buildings having various geometrical discontinuities firstly we need to carry out seismic analysis of a building by one of methods including time history method, response spectra method and static equivalent method. Untill now we have analyzed building by static equivalent method manually.

Further buildings have been similarly analyzed computationally using STAAD.Pro by static equivalent method by varying its geometrical features of building. Effects due to various discontinuities can be studied by varying loads and load combinations. here study is made to see mainly effects on building due to floating column, jumping of load which is initiated in building due presence of floating or hanging column. Case study of comparison of such building with or without floating column is performed. Initially G+ 3 building is considered without floating column as reference model and then for different models were made such that in each case position of floating column was at different floor level. As the provision of hall which demands its area without column in each case were changed. Four such cases were considered designing hall at different floor levels of building and the results of these cases are compared.

**Keywords-** Floating Column, Jumping load, Staad-pro software, Storey drift, Nodal displacements, Base shear.

## I. INTRODUCTION

### 1. Introduction

Many urban multistorey buildings in India today have open first storey as an unavoidable feature. This is primarily being used to accommodate parking or reception lobbies in the first storey. The behavior of a building during earthquakes depends mainly on its overall shape, size and geometry, in addition to how the earthquake forces are carried to the ground. The earthquake forces developed at different floor levels in a building need to be brought down along the height to the ground by the shortest path; any deviation or discontinuity in this load transfer path results in poor performance of the building. Buildings with a few storey wider than the rest cause a sudden jump in earthquake forces

at the level of discontinuity. This sudden jump of earthquake forces or load is jumping load .It is observed that overall maximum load of structure or building is transferred through column. Since column is main element in load transfer path it needs to be without geometrical discontinuity thus it gets essential to avoid features like floating column in building.

**floating column:** A column is supposed to be a vertical member starting from foundation level and transferring the Load to the ground. The term floating column is also a vertical element which (due to Architectural design/ site situation) at its lower level (termination Level) rests on a beam which is a horizontal member. The beams in turn transfer the load to other columns below it.

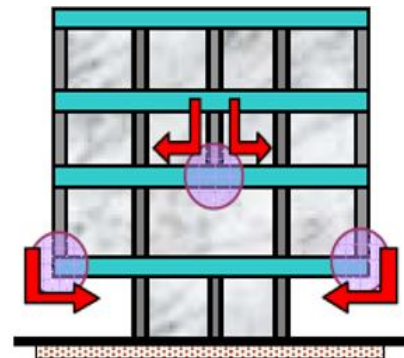

Figure 1. Floating Column

(Source: IITK-BMTPC Earthquake Tip 6)

### 2. Aim

To study Jumping load seismic analysis of multistoried building

### 3. Objective

To study effect of past earthquake

- To study effect of RC structures.
- To study seismic resistance consideration for seismic resistivity.
- To study continues load path and jumping load concept and its effects.

- To simulate RC structure with jumping load consideration subjected to seismic forces, computational.
- To study effect of geometrical discontinuity leading to load jumping on multistory RC structure.

## II. LITURATURE REVIEW

### General:

On the basis of the topic selected various literatures were gone through on the reasons and findings related to earthquake the literatures were studies on

- Reasons for earthquake occurrence
- Global and Indian seismic mapping
- Effect of earthquake on engineering & non engineering structures
- Methods to overcome earthquake effect
- Various load consideration and analysis methods for seismic forces
- Effect of geometrical discontinuity on seismic behavior of structure
- Continues load path, ductile designing etc. for seismic resistivity.

The secondary data from various research journals as well as reports are studied and some important learning's are mentioned below.

**Sabari S, et al. (1)** studied Seismic Analysis of Multistorey Building with Floating Column. The time history of roof displacement, inter storey drift, base shear, column axial force are computed for both the frames with and without Floating Column. The compatible time history and Bhuj earthquake data has been considered. The static and free vibration results obtained using present finite element code is validated. The dynamic analysis of frame is studied by varying column size dimension. It is concluded that by increasing the column size the maximum displacement and inter storey drift values are reducing.

**N. Kara et al.(2)** performed Nonlinear seismic response of structural systems having vertical irregularities due to discontinuities in columns the effects of the structural irregularity which is produced by the discontinuity of a column in a plane frame subjected to seismic loads including the gravity loads is investigated. Investigation is carried out by adopting the linear and the nonlinear static and dynamic analyses of the structural system. The study involves a large number of numerical analysis by considering the plane frame structural systems having a specific height and span

geometries. Results of the numerical analysis are presented including the variation of the normal force in the column to identify the load path in the structural system, the pushover curves to recognize the inelastic weakness of the system and the story drifts to determine the seismic demand in figures. It is found that the results of the nonlinear static and dynamic analyses give much more useful information regarding the irregularity than the linear analysis. Therefore the decision on the acceptance of the column discontinuity or on an empirical rule to deal with the column discontinuity should be based on a nonlinear analysis. Furthermore, it can be employed to determine acceptable degree of irregularity.

**E. Pavan Kumar et al. (3)** performed case study on Earthquake Analysis of Multi Storied Residential Building. In seismic analysis the response reduction was considered for two cases both Ordinary moment resisting frame and Special moment resisting frame. The main objective this paper is to study the seismic analysis of structure for static and dynamic analysis in ordinary moment resisting frame and special moment resisting frame. Equivalent static analysis and response spectrum analysis are the methods used in structural seismic analysis. We considered the residential building of G+15 storied structure for the seismic analysis and it is located in zone II. The total structure was analyzed by computer with using STAAD.PRO software. Finally it can be conclude that the results of static analysis in OMRF & SMRF values are low when comparing to that of dynamic analysis in OMRF & SMRF values. Hence the performance of dynamic analysis SMRF structure is quiet good in resisting the earthquake forces compared to that of the static analysis OMRF & SMRF.

**Nakul A. Patil et al. (4)** made Comparative Study of Floating and Non-Floating Columns With and Without Seismic Behavior work included the analysis and design of the floating column and non floating column structures by using software ETABS-2015. The work done, is to compare the response of RC frame buildings with and without floating columns under earthquake loading and under normal loading. The effect of earthquake forces on various building models for various parameters is proposed to be carried out with the help of response spectrum analysis. Finally, analysis results in the building such as storey drifts, storey displacement, and amount of steel required were compared in this study. The results reveal that the building with non-floating columns is preferable over the building with floating columns during earthquake observations made were Provision of floating columns increases story displacements. Same is with story drift, provision of floating columns increases story drift.

**Shiwli Roy et al. (5)** studied Behavioral studies of floating column on framed structure and presented the floating

column and RCC column analysis on multistoried building and analyzed by STAAD PRO V8i. Here G+3, G+5 and G+10 structures are analyzed and compared with parameters shear force and bending moment. The analysis on floating column for G+3, G+5 and G+ 10 structures showed that if the height of the structure increases, the shear force and bending moment also increases. The column shear varies according to the situation and the orientation of columns also the moment at every floor increases and shear force increases but it is same for each floor column.

**Dr. C.P. Pise et al. (6)** noticed the behavior of floating column for seismic analysis of multistory building. In this paper present study about analysis of G+5 Building with and without floating column in highly seismic zone v. Linear static and time history analysis are carried out of all the two models from linear static analysis compare all the of models result obtained in the form of seismic parameter such as time period, base shear, storey displacement, storey drift .and from time history analysis plot the response of all the models .modeling and analysis done by using sap 2000v17 software. Conclusions drawn on the basis of study are .It was observed that in building with floating column has more time period as compared to building without floating columns also It was observed that in building with floating column has less base shear as compared to building without floating column . It was observed that displacement floating column building is more as compared to without floating column building. It was also observed that building with floating column has more storey drift as compared to building without floating column. From dynamic analysis it was observed that floating column at different location results into variation in dynamic response

**Dr. Om Prakash et al. (7)** studied Seismic Response Evaluation of RC Frame Building with Floating Column. This aims to study the impact of the floating column under earthquake excitation for different soil conditions and where there is no text or zoom determining factor in I.S. The linear dynamic analysis of the 2 D framework of a multi-storey with and without floating column to achieve the above objective no response (effect) factors secure and economical design of the structure under a different excitement earthquake. The results of different models indicate that the presence of the floating column changing moments in the beams and columns analysis. It can be concluded from this behavior building .as noted above, in the case drop side columns. Storey site goes a decisive shift to higher as the peak height of the building. It can also be concluded that the story is the most important site in the high 50% of the structure.

**Sukumar Behera (8)** performed seismic analysis of multistory building with floating column. The behavior of

multistory building with and without floating column was studied under different earthquake excitation. The compatible time history and Elcentro earthquake data has been considered. The PGA of both the earthquake has been scaled to 0.2g and duration of excitation are kept same. A finite element model has been developed to study the dynamic behavior of multi story frame. The static and free vibration results obtained using present finite element code are validated. The dynamic analysis of frame is studied by varying the column dimension. It is concluded that with increase in ground floor column the maximum displacement, inter storey drift values are reducing. The base shear and overturning moment vary with the change in column dimension.

**Stella Evangeline et al. (9)** made push over analysis for RC building with and without floating columns and an attempt was made to reveal the effects of floating column & RC building effected with seismic forces. For this purpose Push over analysis was adopted because this analysis yielded performance level of building for design capacity (displacement) carried out up to failure, it helped determination of collapse load and ductility capacity of the structure. To achieve this objective, three RC bare frame structures with G+4 stories will were analysed and compared the base force and displacement of RC bare frame structure for earthquake forces by varying column dimensions using SAP 2000 14 analysis package.

**Krishna G Nair et al. (10)** reviewed seismic analysis of reinforced concrete buildings. Based upon the accuracy of results needed and the importance of the building that needs be analysed various seismic analysis procedures can be adopted like Linear Static Analysis, Nonlinear Static Analysis, Linear Dynamic Analysis and Nonlinear Dynamic Analysis. Study of all these analysis procedures were carried out in this work. This is especially important in seismic loading, because when a section is designed to yield, and it turns out to be stronger than designed, it may cause the wrong part to yield, putting the whole structure into failure. In smaller structures it may not be worth the effort needed to construct a proper detailed model to investigate the effects of seismic loading. If very accurate and precise result is required from the analysis, non-linear dynamic analysis should be carried out. But this method is more complicated and it requires more computations. Finding relevant time histories for the location chosen can also be a challenge. Therefore alternative methods are needed.

### III. METHODOLOGY

#### PHASE-I

- Study of earthquake occurrences and its effects
- Detail study of seismic analysis method
- Conceptual tips for seismic resistivity
- Detail study of seismic zoning of India

## PHASE-II

- Detail study on effect of geometrical discontinuity in structure
- Detail study on effect of RC structure
- Detail study of IS 1893:2002(static equivalent method)

## IV. DETAIL STUDY

### 1) Seismology Of India

#### Basic Geography of India

India lies at the northwestern end of the Indo Australian Plate, which encompasses India, Australia, a major portion of the Indian Ocean and other smaller countries. This plate is colliding against the huge Eurasian Plate as shown in figure. And going under the Eurasian Plate; this process of one tectonic plate getting under another is called subduction. A sea, Tethys, separated these plates before they collided. Part of the lithosphere, the Earth's Crust, is covered by oceans and the rest by the continents. The former can undergo subduction at great depths when it converges against another plate, but the latter is buoyant and so tends to remain close to the surface.

Three chief tectonic sub-regions of India are the mighty Himalayas along the north, the plains of the Ganges and other rivers, and the peninsula. The Himalayas consist primarily of sediments accumulated over long geological time in the Tethys. The peninsular part of the country consists of ancient rocks deformed in the past Himalayan-like collisions. Erosion has exposed the roots of the old mountains and removed most of the topography. The rocks are very hard, but are softened by weathering near the surface. Before the Himalayan collision, several tens of millions of years ago, lava flowed across the central part of peninsular India leaving layers of basalt rock. Coastal areas like Kachchh show marine deposits testifying to submergence under the sea millions of years ago.

#### Seismic Zones of India

The varying geology at different locations in the country implies that the likelihood of damaging earthquakes taking place at different locations is different. Thus, a seismic zone map is required to identify these regions. Based on the levels of intensities sustained during damaging past

earthquakes, the 1970 version of the zone map subdivided India into five zones – I, II, III, IV and V. The maximum Modified Mercalli (MM) intensity of seismic shaking expected in these zones were V or less, VI, VII, VIII, and IX and higher, respectively. Parts of Himalayan boundary in the north and northeast, and the Kachchh area in the west were classified as zone V. The seismic zone maps are revised from time to time as more understanding is gained on the geology, the seismotectonics and the seismic activity in the country. The Indian Standards provided the first seismic zone map in 1962, which was later revised in 1967 and again in 1970. The map has been revised again in 2002, and it now has only four seismic zones – II, III, IV and V. The areas falling in seismic zone I in the 1970 version of the map are merged with those of seismic zone II. Also, the seismic zone map in the peninsular region has been modified. Madras now comes in seismic zone III as against in zone II in the 1970 version of the map. This 2002 seismic zone map is not the final word on the seismic hazard of the country, and hence there can be no sense of complacency in this regard.

The national Seismic Zone Map presents a large scale view of the seismic zones in the country. Local variations in soil type and geology cannot be represented at that scale. Therefore, for important projects, such as a major dam or a nuclear power plant, the seismic hazard is evaluated specifically for that site. Also, for the purposes of urban planning, metropolitan areas are micro zoned. Seismic microzonation accounts for local variations in geology, local soil profile, etc.

### 2) Seismic Analysis Methods

Seismic analysis is a subset of structural analysis and is the calculation of the response of a building or structure to earthquakes. It is part of the process of structural design, earthquake engineering or structural assessment and retrofit in regions where earthquakes are prevalent.

To do seismic analysis of building following methods

- Seismic Analysis By Response Spectra
- Seismic Response By Time-History Analysis
- Equivalent Static Method

Out of which we are going to study base shear method by IS 1893:2000 in detail i.e. equivalent static method.

Earthquake motion causes vibration of the structure leading to inertia forces. Thus a structure must be able to safely transmit the horizontal and the vertical inertia forces generated in the super structure through the foundation to the

ground. Hence, for most of the ordinary structures, earthquake-resistant design requires ensuring that the structure has adequate lateral load carrying capacity. Seismic codes will guide a designer to safely design the structure for its intended purpose. Seismic codes are unique to a particular region or country. In India, IS 1893 is the main code that provides outline for calculating seismic design force. This force depends on the mass and seismic coefficient of the structure and the latter in turn depends on properties like seismic zone in which structure lies, importance of the structure, its stiffness, the soil on which it rests, and its ductility. Part I of IS 1893:2002 (here after we refer it as the code) deals with assessment of seismic loads on various structures and buildings. Whole the code centres on the calculation of base shear and its distribution over height. Depending on the height of the structure and zone to which it belongs, type of analysis i.e., static analysis or dynamic analysis is performed.

The total design lateral force or design seismic base shear ( $V_b$ ) along any principal direction shall be determined by the following expression:

$$V_b = A_h \times W$$

Now,

The design horizontal seismic coefficient can be determined by following expressions from IS 1893:2002 (Part 1), clause 6.4.2

$$A_h = \frac{Z I S_a}{2R g}$$

Provided that for any structure with  $T < 0.1$  s, the value of  $A_h$  will not be taken less than  $Z/2$  whatever be the value of  $I/R$

$Z$  = Zone factor, to be taken from IS 1893:2002 (Part 1), clause 6.4.2 (Table 2)

$I$  = Importance factor, depending upon the functional use of the structures, characterised by hazardous consequences of its failure, post-earthquake functional needs, historical value, or economic importance IS 1893:2002 (Part 1), clause 6.4.2 (Table 6).

$R$  = Response reduction factor, depending on the perceived seismic damage performance of the structure, the ratio ( $I/R$ ) shall not be greater than 1.0 (Table 7). The values of  $R$  for buildings are given in IS 1893:2002 (Part 1), clause 6.4.2 (Table 7)

$\frac{S_a}{g}$  = Average response acceleration coefficient,

Depends on type of soil and is taken from IS 1893:2002 (Part 1), clause 6.4.5. For this fundamental natural period  $T$  is required which can be taken as clause 7.6.1, 1893:2002 (Part 1).

Thus by obtaining the values as shown above value of acceleration  $A_h$  can be found out.

Also,

$W$  = Total seismic weight of the structure

It depends on the no. of stories structure has and total load each storey carries, total earthquake load is calculated for single storey similarly for each storey load is taken out and sum of loads from each floor is total seismic weight of structure i.e.  $W$ .

For % of imposed load on structure clause 7.3.1 from 1893:2002 (Part 1) can be referred which can be taken as per (Table 8)

By obtaining  $A_h$  and  $W$ , design base shear can be calculated ( $V_b$ ).

The design base shear ( $V_b$ ) computed in 7.5.3 shall be distributed along the height of the building as per the following expression:

$$Q_i = V_b \frac{W_i h_i^2}{\sum_{j=1}^n W_j h_j^2}$$

Where

$Q_i$  = Design lateral force at floor  $i$ ,

$W_i$  = Seismic weight of floor  $i$ ,

$h_i$  = Height of floor  $i$  measured from base,

$n$  = Number of storey's in the building is the number of levels at which the masses are located.

### 3) Seismic resistive consideration for RC structure

For a structure to possess resistivity towards seismic forces it needs to be designed keeping in mind the conceptual design tips which are as discussed below.

1. Light weight
2. Ductility
3. Frame structure
4. Strong bond (beam-column joint)
5. Geometrical shape

- Size of Buildings
- Layout of building (horizontal)
- Layout of Buildings (Vertical)
- Soft storey
- Adjacency of structures
- Floating columns

6. Torsion and Twisting:
7. Structural configurations

- Box action
- Opening and its influence

8. Provision of bands

- Role of Horizontal Bands

- 4) Study of continuous load path

- Gravity load
- Lateral load

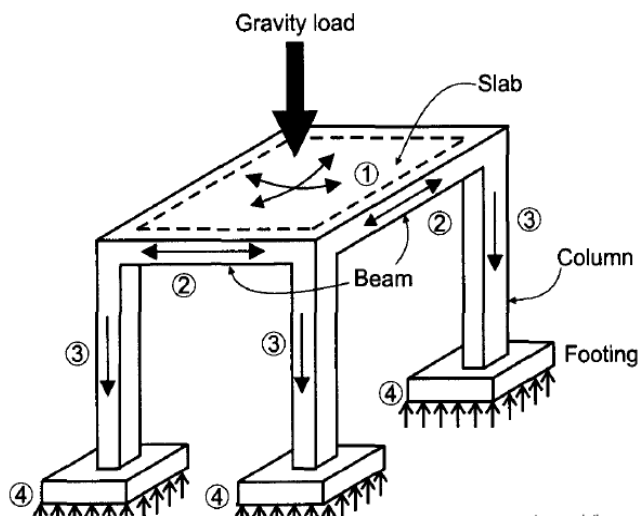

Figure 2. An isometric view of a concrete structure showing a gravity load path.

### 1 Lateral load path

- vertical components: shear walls and frames;
- Horizontal components: roof, floors, and foundations.

## V. CONCLUSION

From the various studies, it has been observed that the effect of seismic forces is tremendous on the structure. However, the various factors are responsible for amplifying the effect of it. With the literature review done, previous study

and learning made it has been found that the geometrical shape plays an important role. Similar way, the role of continuous load path is magnificent. As the upper and the lateral loads needs to be transferred to ground through continuous chain, any of the discontinuity leads to the accumulation of load magnitude. This accumulated load tries to transfer downward, however in condition of missing lower member, the load tries to jump and thus, impact value increases leading to higher destruction. this phenomenon of load accumulation and then sudden transfer in form of jump is known as jumping load and its impact in case of floating column is sever and more destructive as in comparison with structure with complete load paths . thus, study over here shows that floating columns or jumping loads should be eliminated from the structure to reduce seismic disaster effect.

## REFERENCES

- [1] Sabari S, Mr. Praveen J.V (2014-15),” Seismic Analysis of Multistorey Building with Floating Column”, International Journal of Civil and Structural Engineering Research Vol. 2, Issue 2, pp: (12-23),
- [2] N. Kara , Z. Celep (2012), “Nonlinear seismic response of structural systems having vertical irregularities due to discontinuities in columns” world conference on earthquake engineering 2015
- [3] E. Pavan Kumar, A. Naresh, M. Nagajyothi, M. Rajasekhar (2014), “Earthquake Analysis of Multi Storied Residential Building” Int. Journal of Engineering Research and Applications ISSN : 2248-9622, Vol. 4, Issue 11( Version 1), pp.59-64
- [4] Nakul A. Patil ,Riyaz Sameer Shah (2016), “Comparative Study of Floating and Non-Floating Columns With and Without Seismic Behaviour” International Conference on Science and Technology for Sustainable Development (ICSTSD)- 2016
- [5] Shiwli Roy, Gargi Danda de (2015), “Behavioural studies of floating column on framed structure”, International Journal of Research in Engineering and Technology, Volume: 09 Issue: 09
- [6] S.B. Waykule, Dr. C.P. Pise, C.M. Deshmukh, Y.P. Pawar, S.S. Kadam, D. D. Mohite S.V. Lale ,” behaviour of floating column for seismic analysis of multistorey building”, International Journal of Civil Engineering and Technology (IJCIET), Volume 7, Issue 6, November-December 2016, pp. 676–685

- [7] Vinod Kumar Meena, Dr. Om Prakash, Avanish Kumar Mishra (2016), “Seismic Response Evaluation of RC Frame Building with Floating Column”, Volume-6, Issue-2,
- [8] Sukumar Behera (2012), “seismic analysis of multistorey building with floating column”, National Institute of Technology Rourkela- 769008
- [9] Stella Evangeline, D.Satish, E V Raghava Rao( 2015), “push over analysis for RC building with and without floating columns”, International Journal of Advancements in Research & Technology, Volume 4, Issue 11
- [10] Krishna G Nair, Akshara S P (2017), “Seismic Analysis of Reinforced Concrete Buildings-A Review”, International Research Journal of Engineering and Technology (IRJET), Volume: 04 Issue: 02.