

A Low Cost Dishwasher

Harsh Shah¹, Jimit Shah², Mihir Thakkar³, Ronak Prajapati⁴, Asst. Prof. Dixit M. Patel⁵

Department of Mechanical Engineering

^{1,2,3,4}Sal College of Engineering and Technology

⁵Asst. Prof, Sal College of Engineering and Technology

Abstract- In India there are 65% people belong to middle class or lower middle-class family. In the nineties, Videocon came with a concept of the washing machine. They were semiautomatic machines. In the proposed project, a concept of dish washer is shown. The machine would have a capacity of 5 dishes. It will have a vertical motor, which will rotate the entire unit. It would also have nozzles, which would throw the water jet on the objects. It would also have a compressed air spray to dry the objects. The machine will have a speed control mechanism also. The options will be given for jet also. In a nut shell, a machine would serve a purpose for the middle class.

Keywords- Low-Cost Dishwasher, Dishwasher, Cos, Kitchen, Appliances

I. INTRODUCTION

A dishwasher is a mechanical device for cleaning dishware and cutlery. Unlike manual dishwashing, which relies largely on physical scrubbing to remove soiling, the mechanical dishwasher cleans by spraying hot water, typically between 35 and 65 °C, at the dishes, with lower temperatures used for delicate items.

A mix of water and dishwasher detergent is pumped to one or more rotating spray arms, which sprayed the dishes with the cleaning mixture. Once the wash is finished, the water is drained, more hot water is pumped in and a rinse cycle begins. After the rinse cycle finishes and the water are drained, the dishes are dried using one of several drying methods. Typically, a rinse aid is used to eliminate water spots for streak-free dishes or other reasons.

In addition to domestic units, industrial dishwashers are available for use in commercial establishments such as hotels and restaurants, where a large number of dishes must be cleaned. Washing is conducted with temperatures of 65–71 °C (149–160 °F) and sanitation are achieved by either the use of a booster heater that will provide an 82 °C (180 °F) "final rinse" temperature or through the use of a chemical sanitizer.

Users operate dishwashers by scraping food from dirty dishes, loading and then removing the clean dishes. The first mechanical dishwashing device was registered in 1850 in the United States by Joel Houghton for a hand-powered wood

device. This device was made of wood and was cranked by hand while water sprayed onto the dishes. This device was both slow and unreliable. Another patent was granted to L.A. Alexander in 1865 that was similar to the first but featured a hand-cranked rack system. Neither device was practical or widely accepted.

II. OBJECTIVES

- Dish Cleaning
- Flow Variation
- Water jet Spray
- Compressed air spray
- Water jet selection
- Timer Option
- Drainage option available

III. BASIC DESIGN

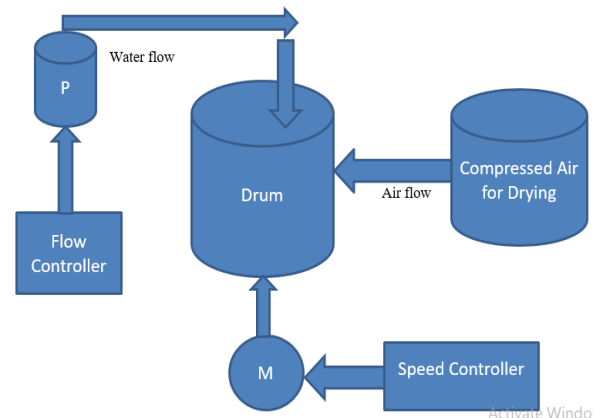

IV. STUDIES AND FINDINGS

The main problem with manual Dishwashing technique is that it takes more time to clean dishes where our washer is great way of time consumption and also saves lot of water than manual dishwashing techniques. Even by manual dishwashing technique some reaction occurs to people by usage of detergent which are basic when added to water. Even the costing of washing dishes is lessened. With reduction of power and energy, there is also reduction of efforts. It needs less maintenance.

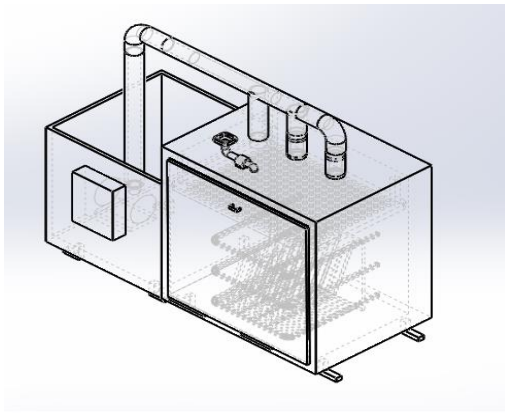

In this generation people is developing by its smart work, it is introducing the mechanical machine to reduce their work and save their time as well as easy handling. This project main aim is that to reduce the work of cleaning the dishes in kitchen. The main object is that to reduce time as well as work for clean the dirty dishes.

V. CONCLUSION

After this project, any middle class person could afford dish washer and have less effort in washing the utensils. Moreover, time could be managed and can do some more important work, even some allergic person to detergent, and water could be saved from harmful side effects. The Low Cost Dishwasher is convenient and easy to use.

REFERENCES

- [1] JoAnn M. Emmel, Kathleen Parrott, Julia Beamish(2003) Dishwashing and Water Conservation: An Opportunity for Environmental Education, Virginia Polytechnic Institute and State University, February 2003 // Volume 41 // Number 1 // Research in Brief // 1RIB3.
- [2] David E. Hoak, Danny S. Parker and Andreas H. Hermelink, How Energy Efficient are Modern Dishwashers?, Florida Solar Energy Center/University of Central Florida, August 2008, FSECCR-1772-08 Commercial Dishwashers, Approved 5/27/09
- [3] Odesola, I. F and Afolabi Olusegun Adigun, Design, Fabrication and Performance Evaluation of a Domestic Dish Washing Machine, AFRREV STECH, Vol.1 (1) January-March, 2012: 164-173 ISSN: 2225-8612
- [4] Gaurav Gosain, Masiha Khan, Thomas Olsen, Niket Prakash and HanyiXie, A More Sustainable Dishwasher, AMU student undergrad, ME 589 Team #1, 16 December 2013
- [5] Sagar P. Jamod and Sachin T. Bagde, Design and Development of Utensils Washer, Department of Mechanical Engineering, YeshwantraoChavan College of

Engineering, Nagpur (India), International Journal on Recent and Innovation Trends in Computing and Communication ISSN: 2321-8169 Volume: 3 Issue: 2 182–184.

- [6] Dhale A. D.1 ,Ghodke L. S2., Hase P. U3. , Jarag S. V4., Shelar S. S5., DESIGN AND DEVELOPMENT OF SEMIAUTOMATIC DISHWASHER, 1-Associate Professor, Mechanical Engineering Dept. Shivajirao S. Jondhale College of Engineering Dombivli (E), Mumbai University Mumbai 2,3,4,5 – Final Year students of Mechanical Engineering Dept. Shivajirao S. Jondhale College of Engineering Dombivli (E), Mumbai University Mumbai International Journal of Engineering Research and General Science Volume 3, Issue 3, May-June, 2015 ISSN 2091-2730.
- [7] Shaila S. Hedao, Dr.C.C. Handa, V.D.Dhopte, Fabrication Of Semi-Automatic Dish And Utensil Washing Machine, 1Research scholar(Mechanical Engg. Design),2Professor and Head of Mechanical Engg.,Department3Professor of Mechanical Department. 1Department of Mechanical Engineering, 1K.D.K.Collage of Engineering, Nagpur-09,India, 2016 IJEDR | Volume 4, Issue 3 | ISSN: 2321-9939.